

Triple Corner Basket Set

Thank you for purchasing this Croydex product. Please follow the fixing and care instructions to ensure your Triple Corner Basket Set is fitted safely and retains its high quality finish. Please retain this leaflet for future reference.

This installation guide applies to the following product:

QM261341- Triple Corner Basket Set with Rust Free Chrome

Home Safety Advice

- Do not strike the product with hard or sharp objects.
- Do not use this product as a grab rail to aid standing up.
- The adhesive pads are suitable for use on most flat, finished surfaces, such as gloss paint, tiles, polished stone, laminates and mildly textured surfaces.
- Do not use on decorative wall paper finishes as these will be damaged on removal.
- Not suitable for unfinished materials such as brick, blockwork and loose, flaky surfaces.
- Do not overload the shelves - maximum weight per shelf is 1.5kg (3.3lbs) evenly distributed.
- Do not use to store glass or breakable items.
- Do not position pad over uneven grout lines.

Product Care

- To retain the best quality finish, clean product regularly with a soft cloth and mild detergents.
- Do not use abrasive or chemical cleaners as these may damage the product.
- Spray cleaning liquids onto the cloth and not directly onto the product.

Pack Contents (Not to scale)

- A** - Middle pole section x 1
- B** - Top pole section x 1
- C** - Foot pole section x 1
- D** - Basket x 3
- E** - Small Rubber O-ring x 3
- F** - Large Rubber O-ring x 3
- G** - Metal Wall bracket x 4

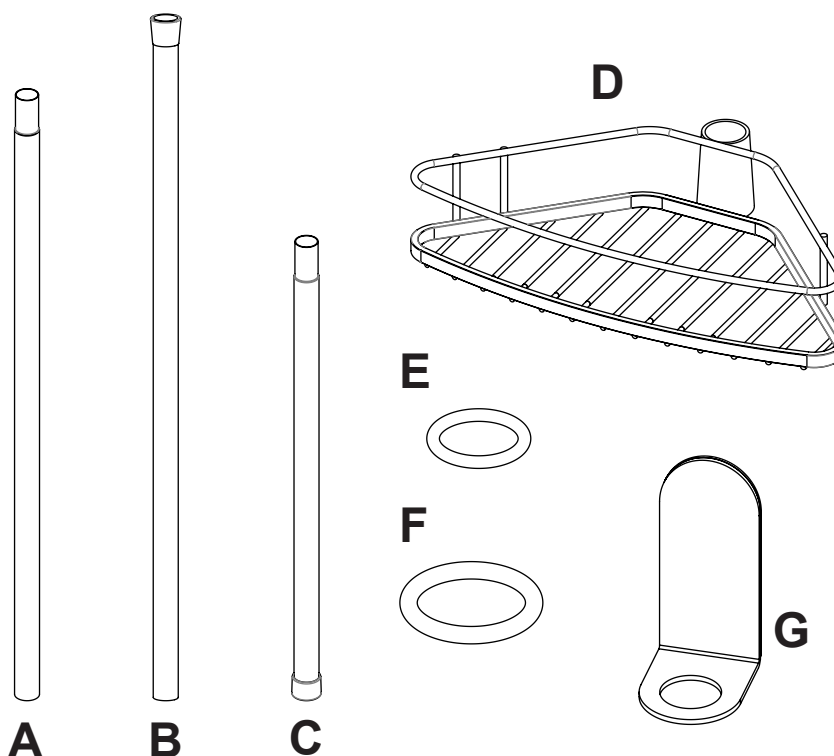

Assembly and Fitting guide

Before Installing

1. Thoroughly clean the mounting surface to remove any dirt, residue or contaminants that may reduce the adhesive performance.
2. Ensure the mounting surface is thoroughly dry and free from loose, flaky material.

Assembly

1. First assemble a wall bracket (G) over the foot pole section (C) so that the end of the bracket points away from the plastic foot at the end of the pole. See Fig 1.
2. Then place a wall bracket (G) over the top pole section (B) as shown so that the end of the bracket points towards the plastic foot at the end of the pole. See Fig 2.
3. Slide a large rubber o-ring (F) over the foot pole section (C) followed by a small rubber o-ring (E). Next slide the tapered section of a basket (D) over the pole and fully locate onto the two o-rings to retain the basket. Fig 3.
Note. It is important that the o-rings are assembled correctly on the pole in the order shown or the basket will not fully locate securely onto them.
4. Then, slide a large rubber o-ring (F) onto the middle pole section (A) followed by a small rubber o-ring (E) making sure that the tapered end of the pole points towards the ceiling. Then slide a basket (D) onto the pole in the orientation shown locating the tapered section of the basket onto the o-rings. See Fig 4.
Note. It is important that the o-rings are assembled correctly on the pole in the order shown or the basket will not fully locate securely onto them.
5. Take the top pole section (B) and slide a basket (D) onto the pole in the orientation shown in Fig 5. Then slide on a small rubber o-ring (E) followed by a large rubber o-ring (F) and slide the tapered section of the basket (D) down the pole and locate fully onto the o-rings. See Fig 5.
Note. It is important that the o-rings are assembled correctly on the pole in the order shown or the basket will not fully locate securely onto them.
6. Connect each of the three pole sub-assemblies together, ensuring to fit the two remaining wall brackets on the pole either side of the middle basket in the orientation shown in Fig 6. **(All wall brackets should point upwards as shown)**

Fitting guide

1. Plan where the assembled product will be located before removing the protective backing from the adhesive pads.
Important Note - The adhesive pads can only be used once and cannot be re-applied.
2. Place the assembled product into its desired location ensuring that all poles are vertically aligned and that the adhesive pads on the metal wall brackets are all touching the same wall. Working one at a time from the top bracket down, rotate the wall bracket around to gain access to the adhesive pad and peel the protective backing off. Carefully rotate the bracket back around without allowing it to touch the wall and position the bracket at the desired height on the pole. Firmly press the bracket against the wall to stick in place. Repeat for the remaining brackets.
Important note - The adhesive pads must be left to cure for 24 hours before weight is placed on the baskets and the product is used.
3. To adjust the height of each basket whilst the unit is assembled to the wall, support the pole with one hand and with the other carefully slide the basket upwards, off the o-rings. Re-position the rubber o-rings at the desired height and relocate the basket fully back onto the o-rings to secure in place.
Important note - Ensure each basket is fully located over the o-rings to prevent the basket from working loose and sliding down the pole.

Fig 1

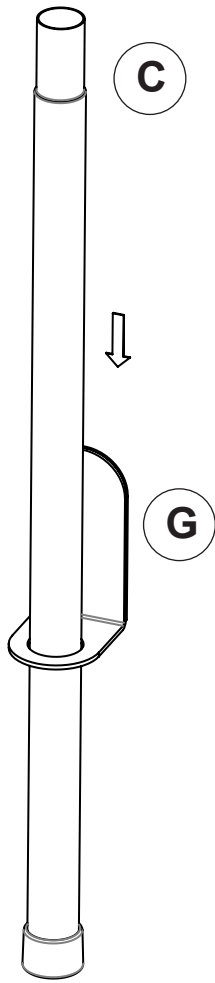

Fig 2

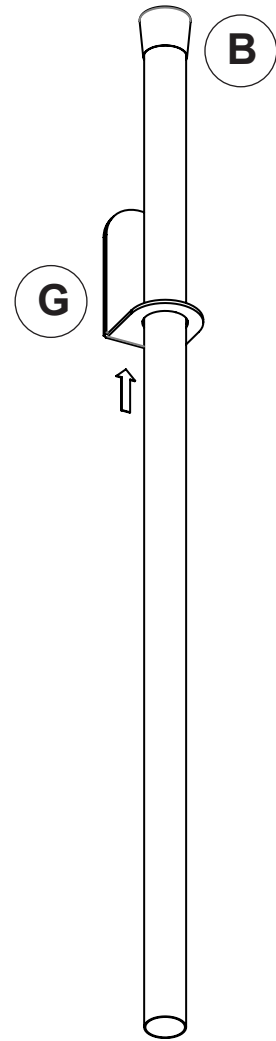

Fig 3

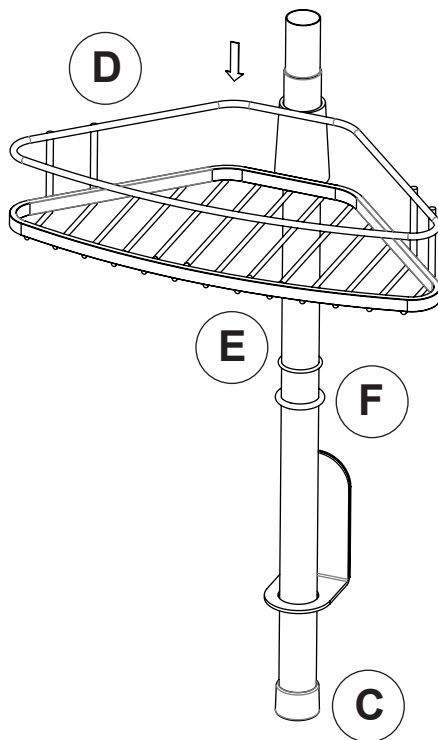

Fig 4

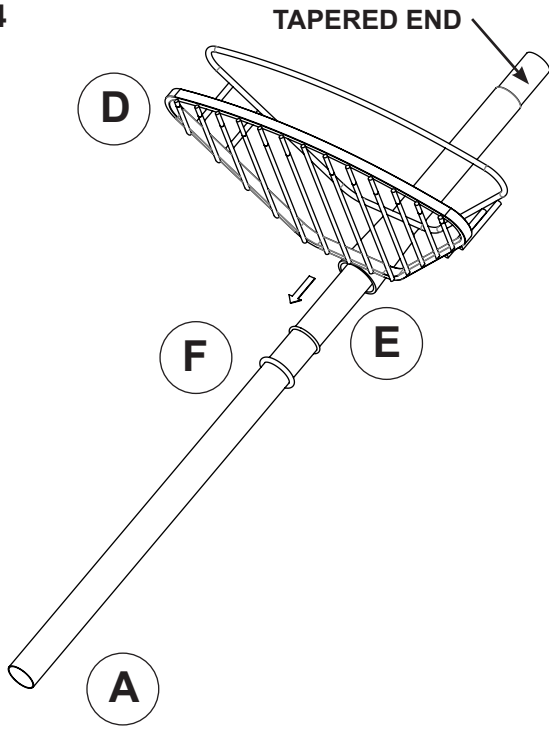

Fig 6

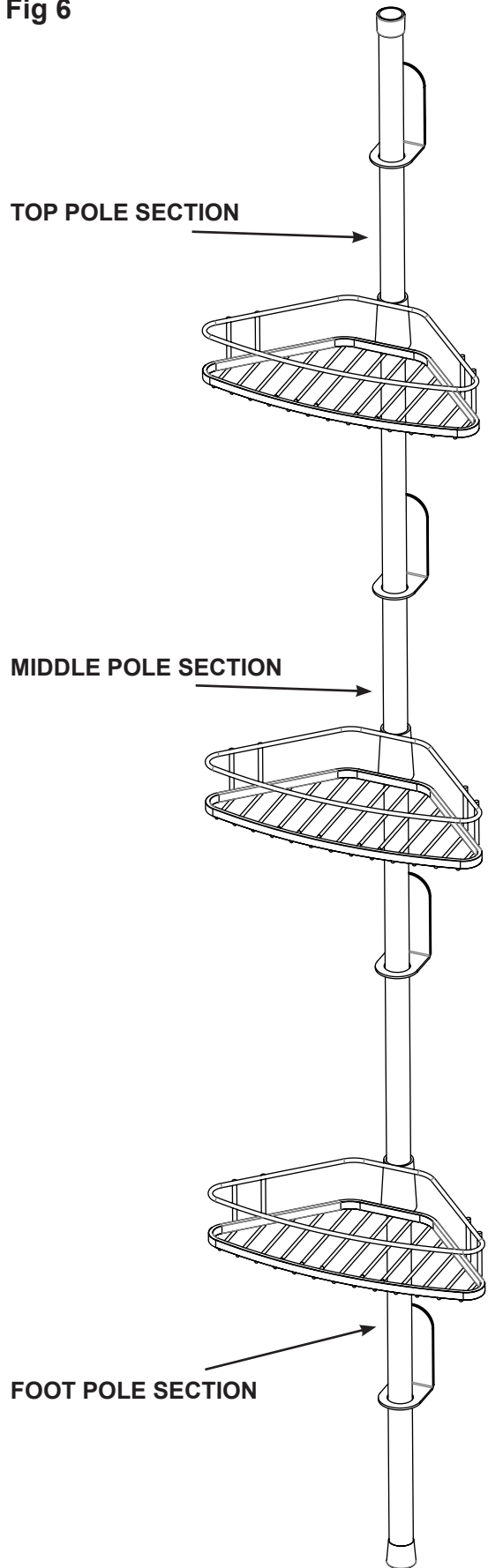
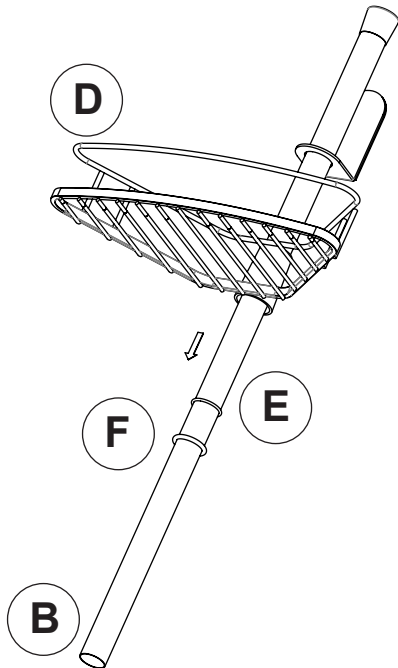

Fig 5



5-year Anti-corrosion Guarantee

This product is guaranteed against corrosion for 5 years. Please retain a copy of your receipt which must be presented should a guarantee claim be necessary. This guarantee covers corrosion under normal usage, when the product is installed, used and cleaned in accordance with these instructions. This guarantee does not cover corrosion resulting from damage to the protective coating due to the use of abrasive sponges or pads, abrasive cleaners, strong chemical cleaners or metal polish. In the unlikely event that corrosion should occur during the guarantee period we will replace the product.

For details of the other items in the Croydex range please visit our website: www.croydex.com

Croydex, Central Way,
Andover, Hampshire, SP10 5AW, UK
Tel: +44 (0) 1264 365881 Fax: +44 (0) 1264 356437
E-mail: info@croydex.co.uk