

3 Drawer Base
300, 500mm

Components

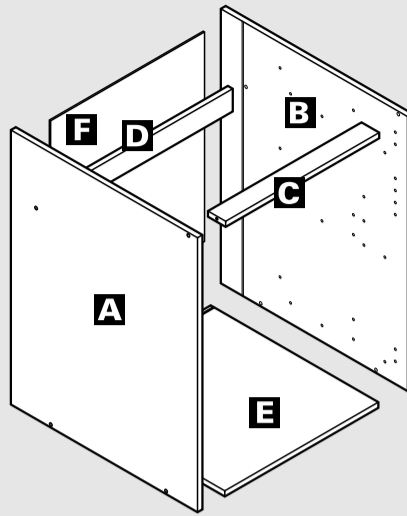

- A** Left End Panel
L. Zijpaneel
Panneau Lateral Droit
- B** Right End Panel
R. Zijpaneel
Panneau Lateral Gauche
- C** Front Rail (54mm)
Voorrail
Traverse Avant
- D** Back Rail (60mm)
Achtersterail
Traverse Arriere
- E** Bottom Panel
Onderpaneel
Panneau de Fond
- F** Back Panel
Achterpaneel
Panneau Arriere

Drawerbox / Ladencast / Tiroir

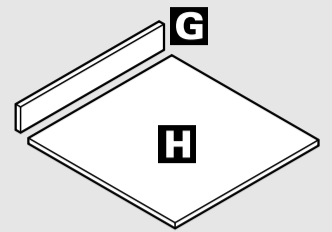

- G** Back Panel x3
Achterpaneel x3
Panneau Arriere x3
- H** Bottom Panel x3
Onderpaneel x3
Panneau de Fond x3

Tools required

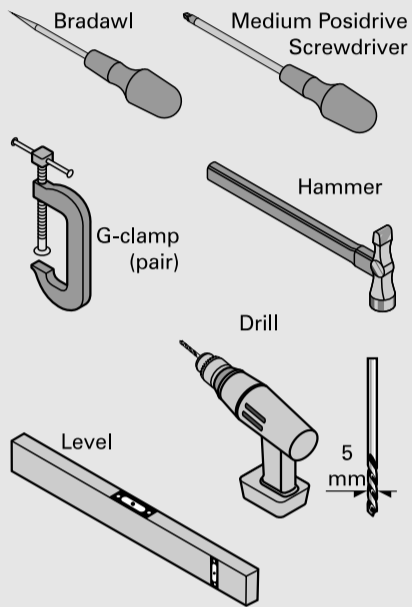

Note / Op / Noter

Caution: Some pieces of hardware could be hazardous to small children. Keep all these items out of reach and do not leave children unattended in the assembly area. Please read these instructions carefully before proceeding. Some of these units are quite large and may have to be assembled in the room where they are to be installed.

Note: Due to the variation in wall conditions, no screws are supplied for fixing the unit to the wall. If in doubt consult an expert. Assemble the unit on a clean solid work surface.

Please Note: Every effort has been made to ensure that this product leaves the factory in perfect condition. Any item which has a visible defect must not be installed and returned to the place of purchase.

In the interest of continuing improvements, we reserve the right to amend or adjust the specifications without prior notice. Errors and omissions excepted.

Waarschuwing: Bepaalde montage-elementen kunnen gevaar opleveren als ze in handen van kleine kinderen raken. Houd deze voorwerpen buiten het bereik van kinderen. Zorg dat kinderen zich niet zonder begeleiding in de ruimte kunnen bevinden waar het montagewerk plaatsvindt. Alvorens aan de slag te gaan, adviseren wij u deze instructies nauwkeurig door te lezen. De kasten zijn vrij groot. Daarom kan het raadzaam zijn, ze te monteren in de ruimte waar ze uiteindelijk komen te staan.

N.B.: Omdat muren in verschillende huizen van verschillend materiaal kunnen zijn, zijn er geen schroeven voor wandmontage bijgeleverd. In geval van twijfel raden wij u aan een deskundige te raadplegen. Zet de kast op en schone, solide ondergrond in elkaar.

Let Op: Er is alle mogelijke moeite gedaan om ervoor te zorgen dat dit product u in perfecte staat bereikt. Elk product waaraan duidelijk schade te zien is, mag niet geïnstalleerd worden en dient te worden geretourneerd aan het bedrijf waar u het gekocht heeft en waar het product vergoed zal worden.

In het belang van voortdurende verbetering, behouden wij ons het recht voor om specificaties te veranderen of aan te passen zonder voorafgaande mededeling. Fouten en weglatingen uitgezonderd.

Attention: Certains éléments d'équipement peuvent éventuellement être dangereux pour les petits enfants. Veuillez ne pas mettre ces éléments à leur portée et ne jamais laisser d'enfants sans surveillance dans la zone d'assemblage. Veuillez lire ce mode d'assemblage attentivement avant de continuer.

Certaines de ces armoires sont assez grandes et peuvent exiger d'être assemblées dans la pièce dans laquelle elles seront installées.

Remarque: En raison des différentes conditions des murs, aucune vis n'est fournie pour la fixation des éléments au mur. En cas de doute, consultez un expert. Assemblez l'élément sur un plan de travail solide et propre.

Veillez noter: Tout a été fait pour assurer que ce produit quitte l'usine en parfait état. Tout article visiblement défectueux ne doit pas être installé et doit être retourné au point de vente où il vous sera remboursé.

Dans le cadre de notre politique d'amélioration continue, nous nous réservons le droit de modifier ou d'ajuster les spécifications sans préavis. Sauf erreur et omission.



Ref. No.	Item	Quantity	Ref. No.	Item	Quantity	Ref. No.	Item	Quantity	Ref. No.	Item	Quantity
150101	3.5 x 13mm	48	150901	50mm Confirmat	8	152401	(Image)	4	153111 (pack)	(Image)	3
150080	(Image)	24	(Image)	(Image)	8	152400	(Image)	4	(Image)	(Image)	3
150203	3.5 x 13mm	12	154068	(Image)	4	(Image)	(Image)	3	(Image)	(Image)	6
150202	4.5 x 13mm	12	151999	(Image)	6	152402	(Image)	3	(Image)	(Image)	3 x 'L'; 3 x 'R'

1-2

Drawer Runner and Softclose Adaptor Locations- Dimensions are to the centre of the mounting holes.
Posities van Lade Glijder en Softclose Deurdemper- De getallen geven de afstand aan tot het hart van de montage-openingen.
Positions pour le Rail du Tiroir et L'Adapteur Softclose- Les dimensions sont par rapport au centre des trous de montage.

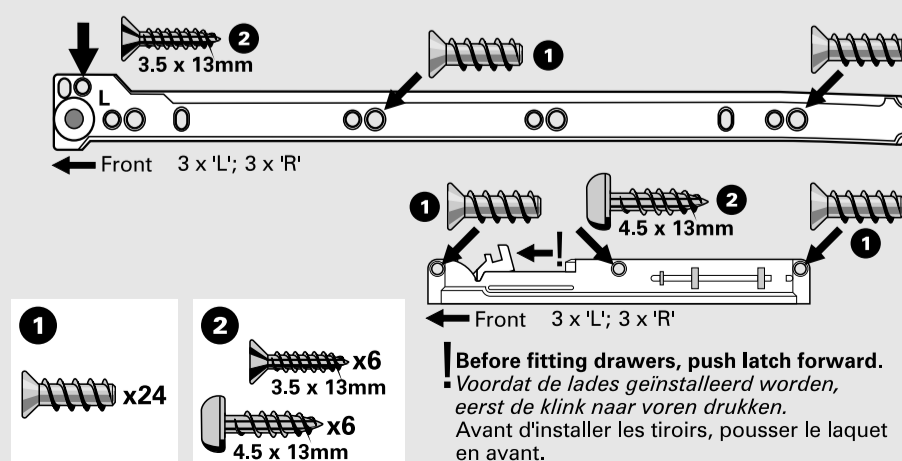
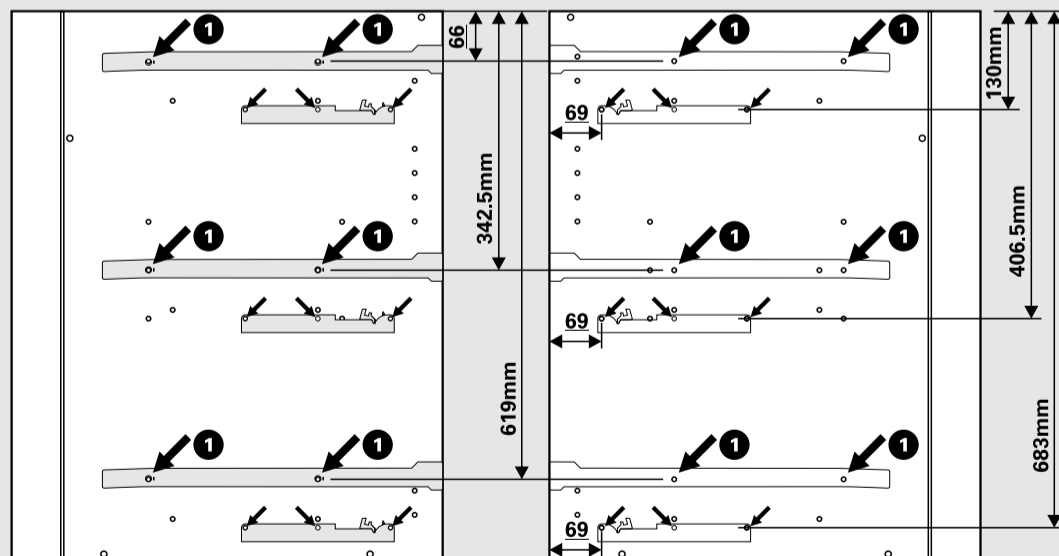

Fit an extra screw after attaching the runner with the system screws.
Na het bevestigen van de geleider met behulp van de systeem Schroeven dient u één extra schroef aan te brengen.
Ajoutez une vis après avoir attaché la glissière avec les vis du système.

Before fitting drawers, push latch forward.
Voordat de lades geïnstalleerd worden, eerst de klink naar voren drukken.
Avant d'installer les tiroirs, pousser le laquet en avant.

3-4

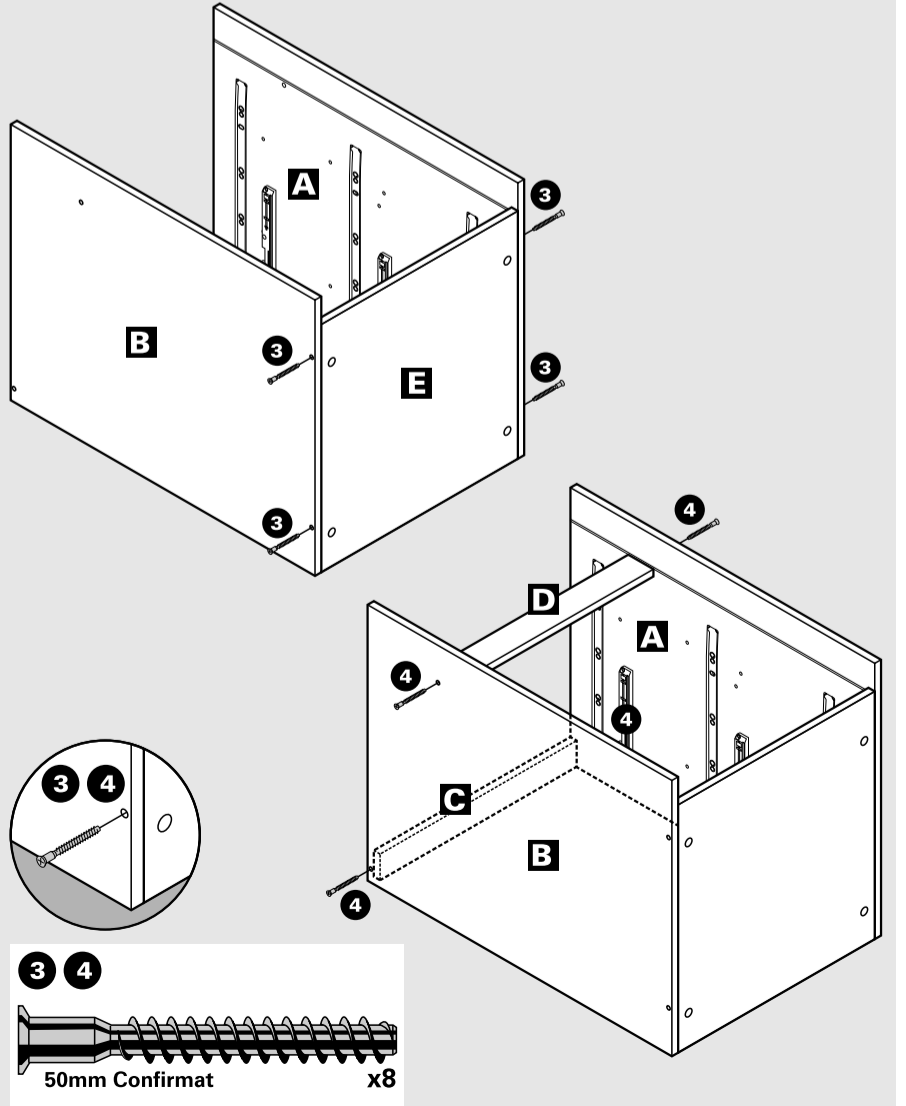

5

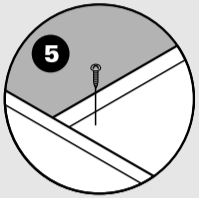
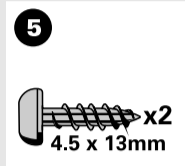
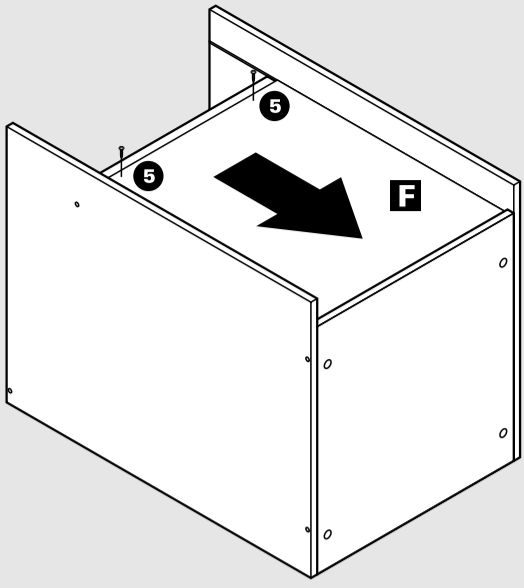

6-7

Position sockets as shown. The tab on the sockets must go over the end panels (A,B). At the end of a run of units, turn the sockets 45° so the tabs do not overhang as far. Notch the return plinth so it will clip on to the legs.

Set all legs to 140mm high before standing unit upright.
IMPORTANT: Do not stand the unit upright by lifting against the legs.

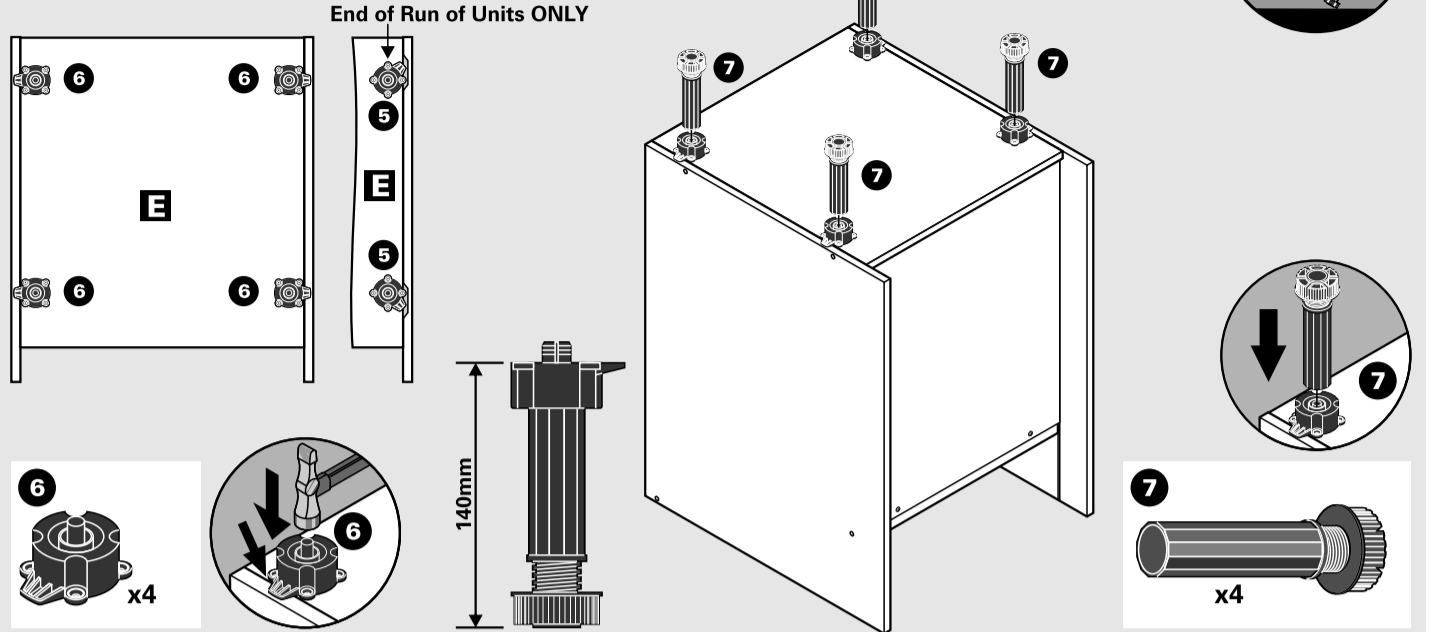

8-9

Level the units. Fix together with suitable fixings (not supplied). Fit the brackets and secure to the wall with suitable fixings (not supplied). Do not use cover caps between the units.

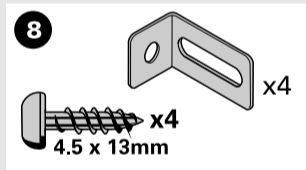
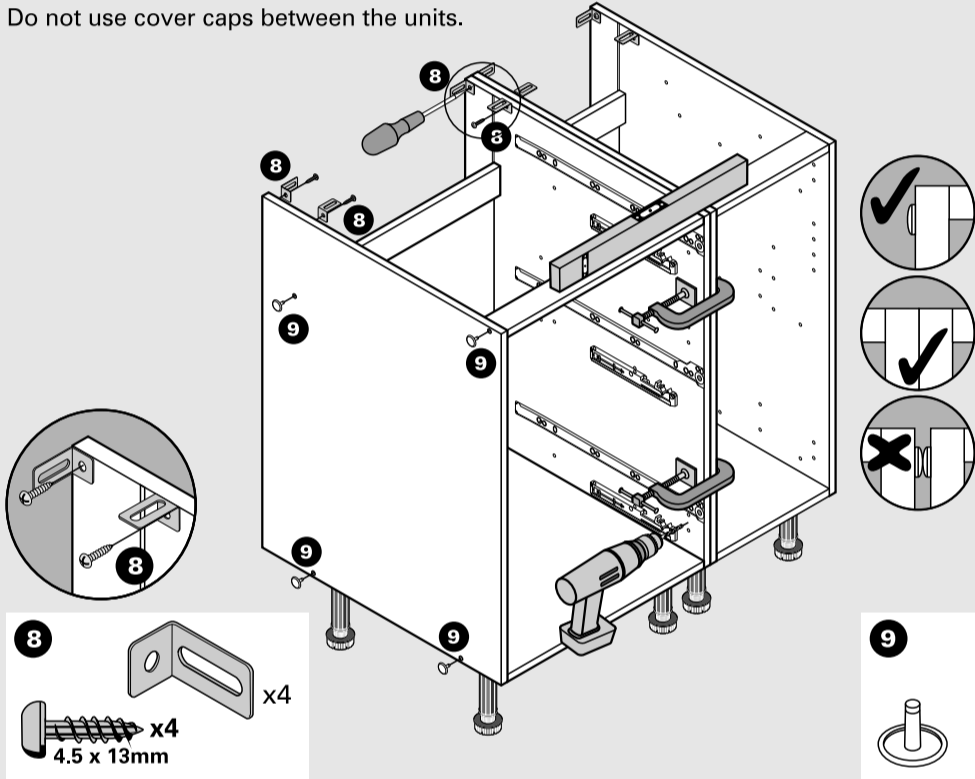

10

Cut the Continuous plinth to the length of all the units. Finish the cut ends with the edging tape provided with the plinth. The return plinth will need to be notched on the inside as shown to clear the legs.

Fit the clip on the return plinth the other way up.
* A clip is not necessary on all the legs.

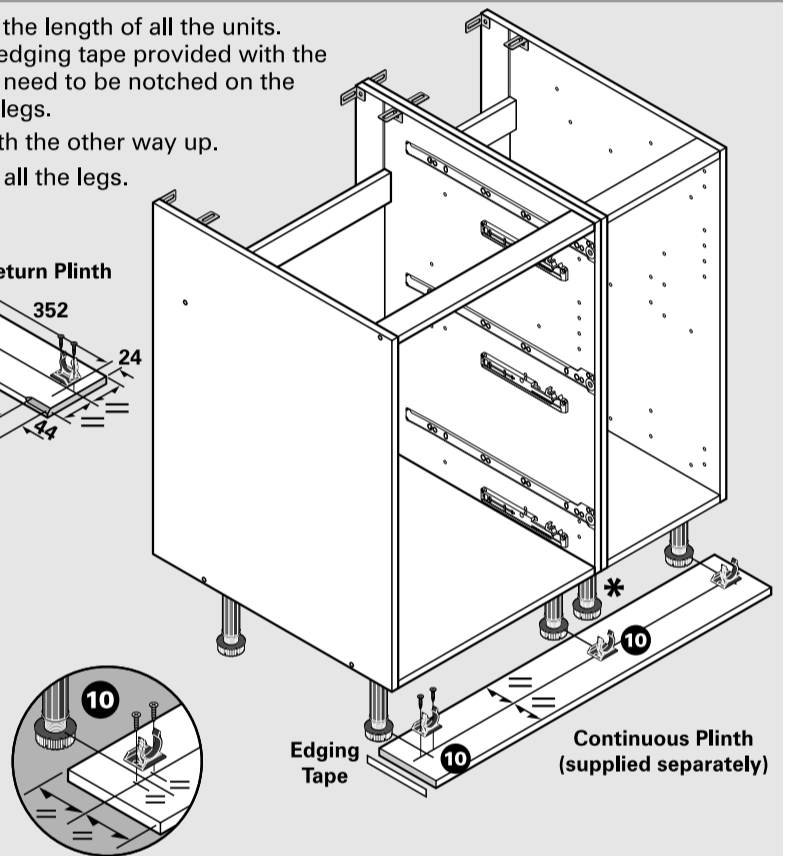
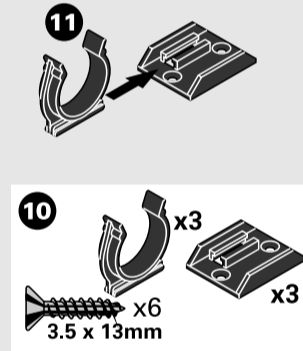
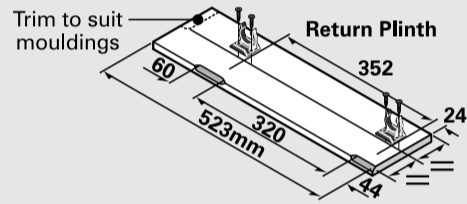

11 Drawerbox

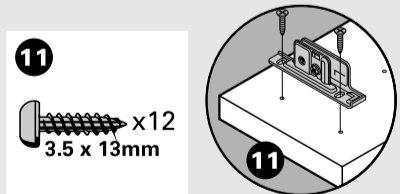
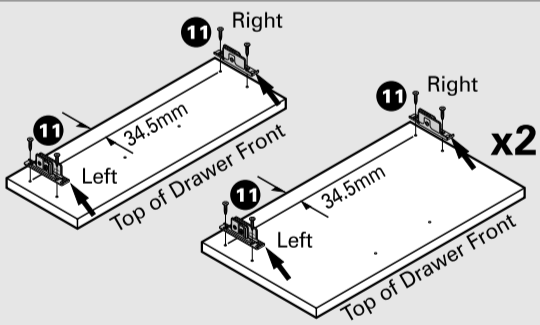

12

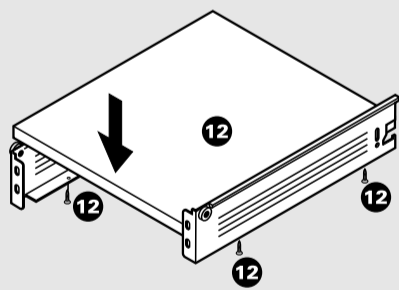

13

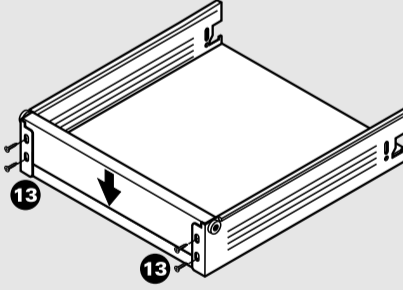

14-15

Please Note: Tighten screws when drawers have been installed and aligned in base unit.

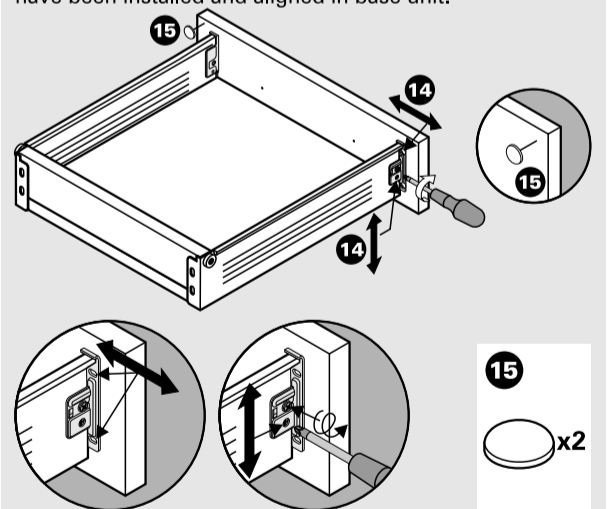

16

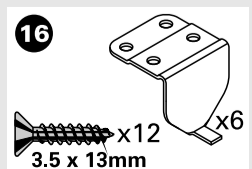
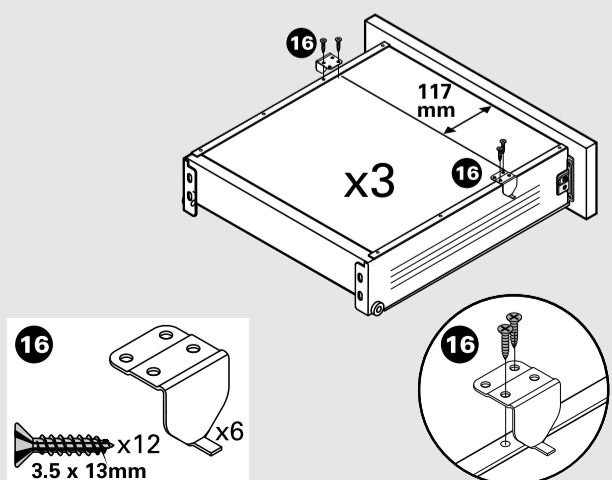

17

Drawer Handle Drilling
All drawer fronts are part drilled on the back for a handle. Some drawer fronts may be part drilled in several places. Please decide the handle position on all units and check all details carefully before drilling as drilled drawer fronts cannot be returned. Use a 5mm flat-tipped drill bit and drill into a piece of scrap wood to prevent splintering. It is recommended that the drawers are fitted before drilling.

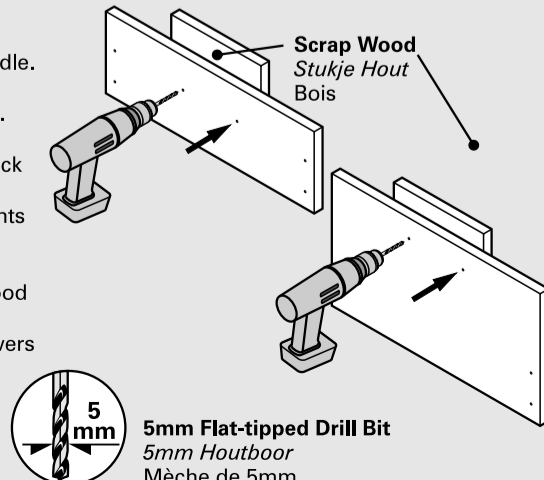

5mm Flat-tipped Drill Bit
5mm Houtboor
Mèche de 5mm

Maintenance

These units have been designed to give years of pleasure and satisfaction. You will help maintain the original beauty of your kitchen by following these guide lines.

Sealing: All cut edges where raw chipboard is exposed on both the worktop and the carcass must be sealed with a moisture resistant sealer such as gloss paint, varnish or silicone sealant.

Cleaning: Any spillage, even water, should be removed from the surface immediately. Remove any marks with a soft damp cloth and mild household detergent. Wipe over with a damp cloth to remove any excess moisture and dry with a soft, clean cloth. Do not use solvents, abrasive cleaners or pigmented glass cleaners.

Drawers, Runners, Doors And Hinge: The roller runners and hinges are factory lubricated. Do not clean with solvents as the operation of the moving parts will be affected. Never pull or lean on partially or fully open doors and drawers.