

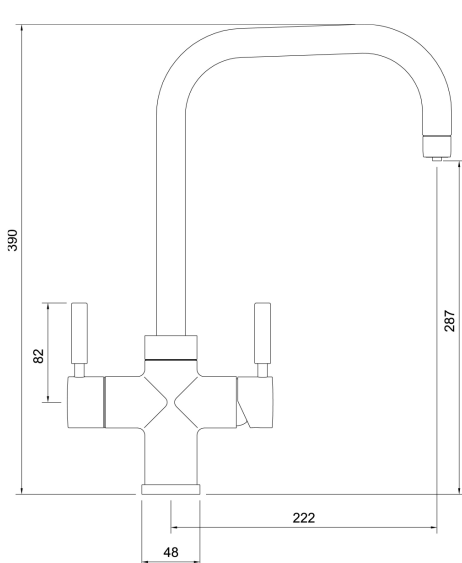

**Product Features:**

- Stylish 3 way mixer tap delivering domestic hot, cold and 98° filtered water
- The dual stage handle mechanism on the hot handle has been designed with safety and ease of use in mind
- 360 degree rotation of spout allows for easy use and accessibility
- Anti splash aerator as standard
- Features an energy saving cold start valve as standard
- 5 Year Warranty\*
- WRAS approval pending

**Product dimensions:**



- **Overall Height / projection:** 427mm
- **Exit spout reach:** 222 mm
- **Exit spout height:** 287 mm
- **Base diameter(s):** 48 mm
- **Recommended hole diameter:** Ø35 mm
- **Max. surface depth:** 50 mm
- **Spout diameter:** 24 mm
- **Spout aerator size:** M22x1 Male

**Product flow characteristics:**

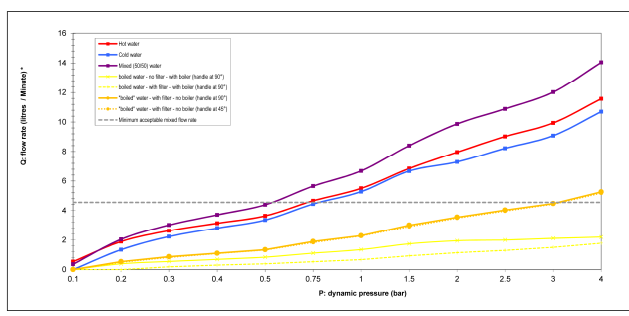

- **Min cold water pressure:** 1.5 bar
- **Min hot water pressure:** 0.75 bar
- **Recommended / Maximum domestic hot water temperature:** 46°C / 70°C
- **Part G - Mixed flow rate at 3 bar (litres / min):** 12.02
- **Control valve type:** 1 x 1/2" Ceramic disc QT, 1 x Single lever 35mm
- **Product flow characteristics:** (H&C/Boiling) dual flow
- **Aerator type:** Neoperl aerator honeycomb
- **Hot and Cold inlet connections:** flexi hose
- **Non return valve(s):** Yes, integral to cold inlet flexi hose only

**Care instructions summary:**

- Clean the product regularly as required, using a mild soap and damp cloth, do not use any other cleaners, regular cleaning will prevent the build-up of lime scale and dirt
- Residues of sink & worktop cleaners can also cause damage to the mixer tap, so rinse with clean water after using, avoid contact with any abrasives

**Warranty Summary** (Full details available on request):

- Mixer tap materials and workmanship defects warranted for 5 years
- Probol2 materials and workmanship defects warranted for 2 years
- Mixer tap valves and working parts warranted for 5 years
- Surface finish warranty defects warranted for 1 year
- All o-rings, hoses & gaskets warranted for 1 year



### PROBOIL2 features:

- Compact size to fit discreetly into your base unit (Overall height 257mm, Width 217mm, Depth 175mm)
- Filtered water inlet
- 98 degree water outlet
- Safety steam vent to a standard dishwasher connection
- Removable tank lid for easy access, cleaning and descale
- 2 Litre tank
- Boiler can be floor or wall mounted
- UK manufactured boiler
- 2 Year Warranty\*
- WRAS approval pending

\*All temperatures quoted are measured within the tank of the boiler and actual spout exit temperature may vary dependant local conditions.

For further information refer to [proboil.co.uk](http://proboil.co.uk) and our user guide.

### Our premium quality PROBOIL2 filter offers the following benefits:



- Filtered 98°C drinking water, engineered specifically for hot water applications
- Included with every PROBOIL2 system
- Recommended / Maximum replacement interval: 6 / 12 months
- Chlorine taste and odour reduction.
- Inbuilt corrosion protection
- Mineral adaption and scale reduction for protection
- Reduces scaling potential of the water
- WRAS approved



### The complete package:

Each PRONTEAU system includes:

- A stylish choice of intelligent 3 way PRONTEAU mixer taps
- PROBOIL2 hot water boiler
- PROBOIL2 scale control filter & assembly
- Connecting hoses and safety vent
- Comprehensive user and installation guide
- Waste Plumbing Attachments
- Nationwide professional maintenance and service support

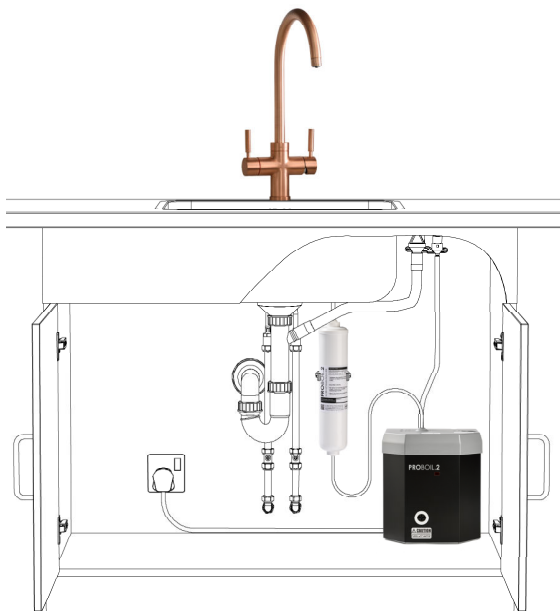

# WATER THE WAY YOU WANT IT