

03HEL0808DDFW-V2

8x8 Helios Summerhouse

BEFORE YOU START PLEASE READ INSTRUCTIONS CAREFULLY

- Check the pack and make sure you have all the parts listed.
- When you are ready to start, make sure you have the right tools at hand (not supplied) including a Phillips screwdriver, Stanley knife, wood saw, step ladder and drill with 2mm bit.
- Ensure there is plenty of space and a clean dry area for assembly.

TIMBER

As with all natural materials, timber can be affected during various weather conditions. For the duration of heavy or extended periods of rain, swelling of the wood panels may occur. Warping of the wood may also occur during excessive dry spells due to an interior moisture loss. Unfortunately, these processes cannot be avoided but can be helped. It is suggested that the outdoor building is sprayed with water during extended periods of warm sunshine and sheltered as much as possible during rain or snow.

Once your garden building has been installed it will need to be treated as soon as possible and annually to prevent the timber from deteriorating and to waterproof it. This is required to maintain the anti-rot guarantee.

Dip Treated buildings - Require a preservative treatment to protect against rot and decay and a waterproof treatment to prevent water ingress

Pressure Treated buildings - Require a waterproof treatment to prevent water ingress

Log Cabins - Are supplied untreated and require a preservative and waterproofing treatment.

BUILDING A BASE

When thinking about where the building and base is going to be constructed:
Ensure that there will be access to all sides for maintenance work and annual treatment.

Ensure the base is level and is built on firm ground, to prevent distortion. Refer to diagrams for the base dimensions, The base should be slightly smaller than the external measurement of the building, i.e. The cladding should overlap the base, creating a run off for water. It is also recommended that the floor be at least 25mm above the surrounding ground level to avoid flooding.

TYPES OF BASE

- Concrete 75mm laid on top of 75mm hard-core.
- Slabs laid on 50mm of sharp sand.

Whilst all products manufactured are made to the highest standards of Safety and in the case of childrens products independently tested to EN71 level, we cannot accept responsibility for your safety whilst erecting or using this product.

Refer to the instructions pages for you specific product code



x2

All building's should be erected by two adults



Winter = High Moisture = Expansion
Summer = Low Moisture = Contraction



2mm Drill bit

For ease of assembly, you **MUST** pilot drill all screw holes and ensure all screw heads are countersunk.



CAUTION

Every effort has been made during the manufacturing process to eliminate the prospect of splinters on rough surfaces of the timber. You are strongly advised to wear gloves when working with or handling rough sawn timber.

Protim Aquatan T5 (621)

Your building has been treated with **Aquatan**.

Aquatan is a water-based concentrate which is diluted with water, the building as been treated by the correct application of Aquatan solution and then allowed to dry.

Aquatan is a decorative finish to colour the wood, which is applied industrially to timber fence panels and garden buildings.

Aquatan undiluted contains: boric acid, sodium hydroxide 32% solution, aqueous mixture of sodium dioctyl sulphosuccinat and alcohols: 2, 4, 6-trichlorophenol.

For assistance please contact customer care on: 01636 821215

**Mercia Garden Products Limited,
Sutton On Trent,
Newark,
Nottinghamshire,
NG23 6QN**

www.merciagardenproducts.co.uk

03HEL0808DDFW-V2

Please retain product label and instructions for future reference

Overall Dimensions:
Length = 2506mm
Width = 2942mm
Height = 2137mm



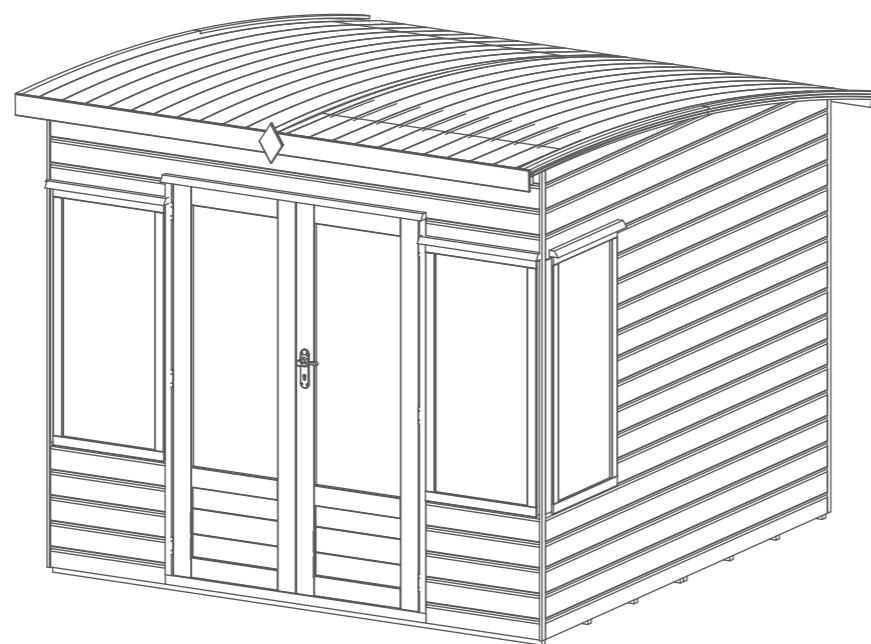

Base Dimensions:
Length = 2387mm
Width = 2400mm

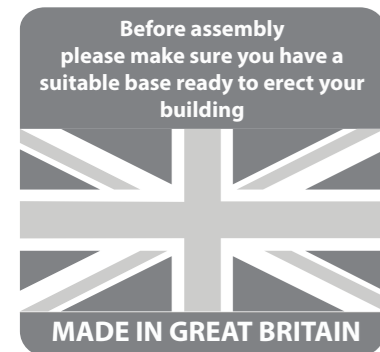

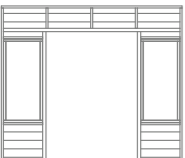
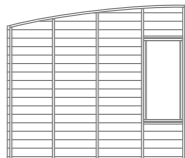
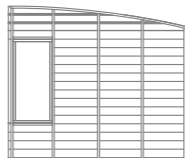
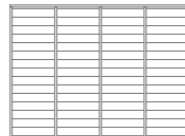
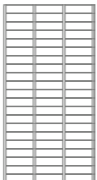







- 23 
Key Plate
- 24 
Hinge QTY 6
PI-07-0023
- 25 
Turn Button QTY 2
PI-07-0034
- 26 
Tower Bolt QTY 2
PI-07-0114
- 27 
Finial QTY 2









- 1 
Door Panel
AI-03HELDP2392X2093-V1
- 2 
Right Gable
AI-03HELWGR2382X2093-V1
- 3 
Left Gable
AI-03HELWGL2382X2093-V1
- 4 
Back Panel
AI-03HELBP2392X1821-V1
- 5 
Floor QTY2
AI-03TAGFLOOR2387X1200-V1

- 6 
Roof QTY2
AI-03TAGROOF1253X2960-V1
- 7 
Master Door
AI-03HEL1010MD
- 8 
Slave Door
AI-03HEL1010SD
- 9 
Roof Bar QTY3
AI-03HELRB2304X101-V1

- 10 
Roof Block - 28x28x140mm QTY 6
FS2828-160mm (angled)
- 11 
Large Rain Guard - 28x44x1272mm
RG2844-1272mm
- 12 
Small Rain Guard - 28x44x580mm QTY 4
RG2844-580mm

- 13 
Roof End - 100x12x2950mm QTY 2
MBRT100-2950mm
- 14 
Door Beading - 17x12x1711mm QTY 2
BDC-1711mm
- 15 
Bottom Roof Trim - 30x12x1455mm QTY 4
S1230-1455mm
- 16 
Top Roof Trim - 30x12x1510mm QTY 4
S1230-1510mm
- 17 
Fascia - 95x12x1253mm QTY 2
SR1295-1253mm

- 18 
Front Cover Trim - 30x12x2088mm QTY 2
S1230-2088mm
- 19 
Rear Cover Trim - 30x12x1827mm QTY 2
S1230-1827mm
- 20 
Door Bar - 60x16x1705mm
F1660-1705mm
- 21 
Door Handle
PI-07-0001
- 22 
Mortice Lock
PI-07-0017

- Nail Bag**
- 
80mm Screw x14
 - 
40mm Screw x80
 - 
60mm Screw x38
 - 
30mm Screw x104
 - 
50mm Screw x46
 - 
30mm Black Screw x3
 - 
Felt Tacks x170

Pre Assembly

Remove the transportation blocks from the bottom of each panel before beginning assembly.

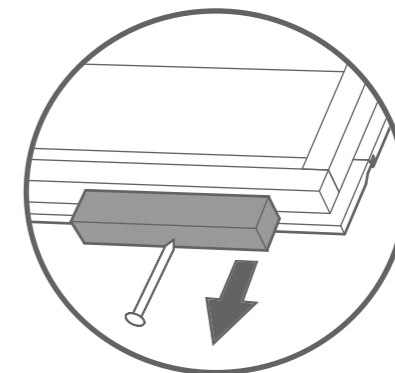

Step 1

Position the floor (**No.5**) sections together as shown in the illustration, ensure that the floors are flush together and secure into position using 16x50mm screws.

Screw through the top of the floor diagonally into the bearer.

16x50mm Screws

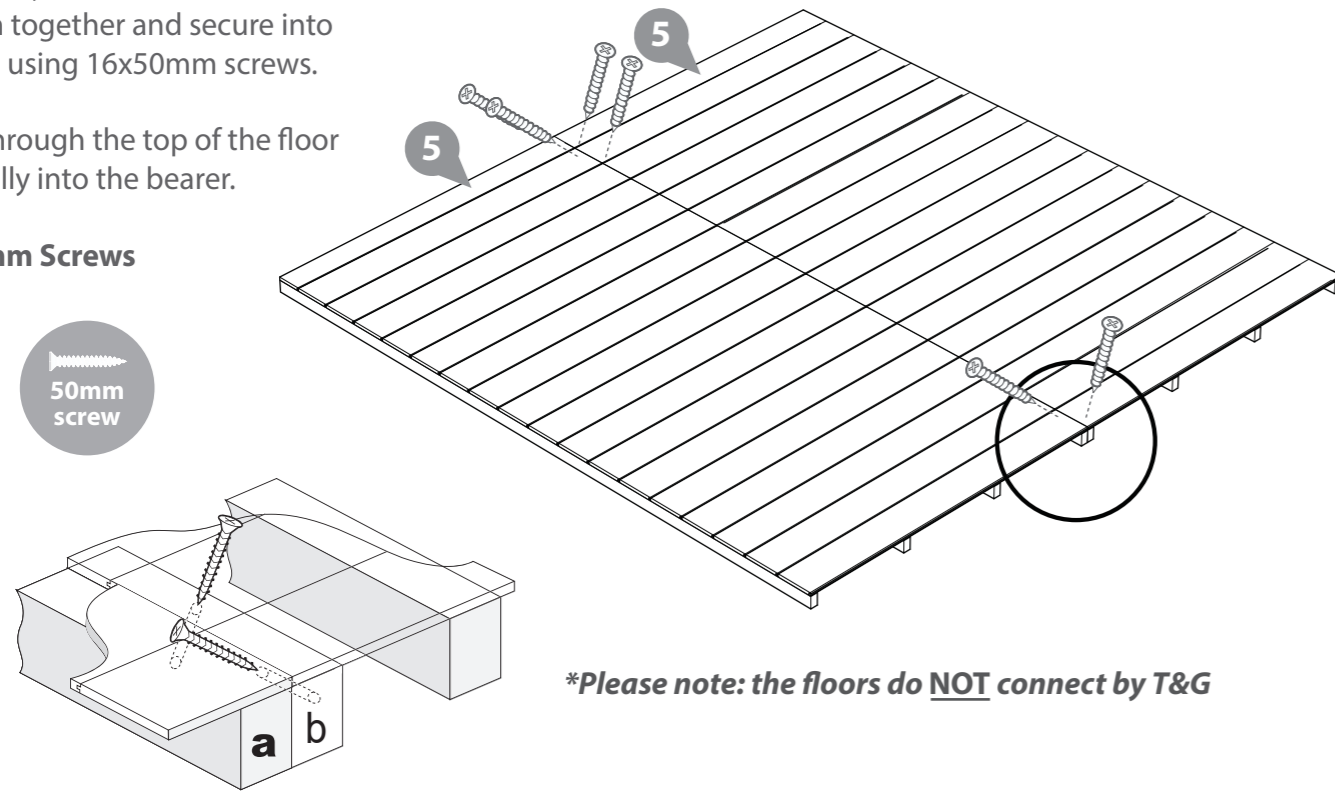

**Please note: the floors do NOT connect by T&G*

Step 2 Door Fixings

Join the flush hinges (**No. 24**) to the door frames (**No. 7 & 8**) using 30mm screws. Ensure hinges are attached using the outer plate of the hinge.

Fit the doors to the door panel with 30mm screws making sure to use the inner plate of the hinge.

36x30mm screws

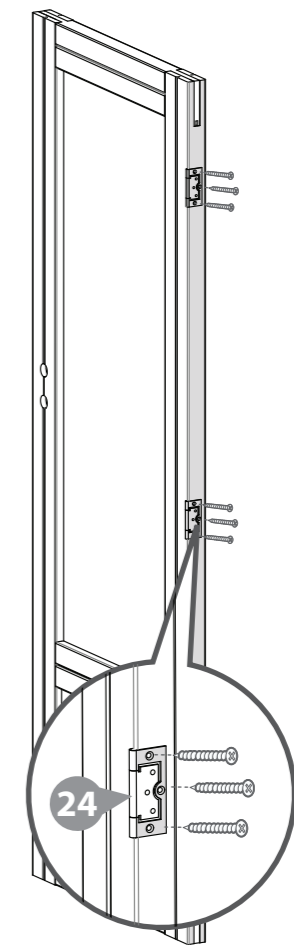
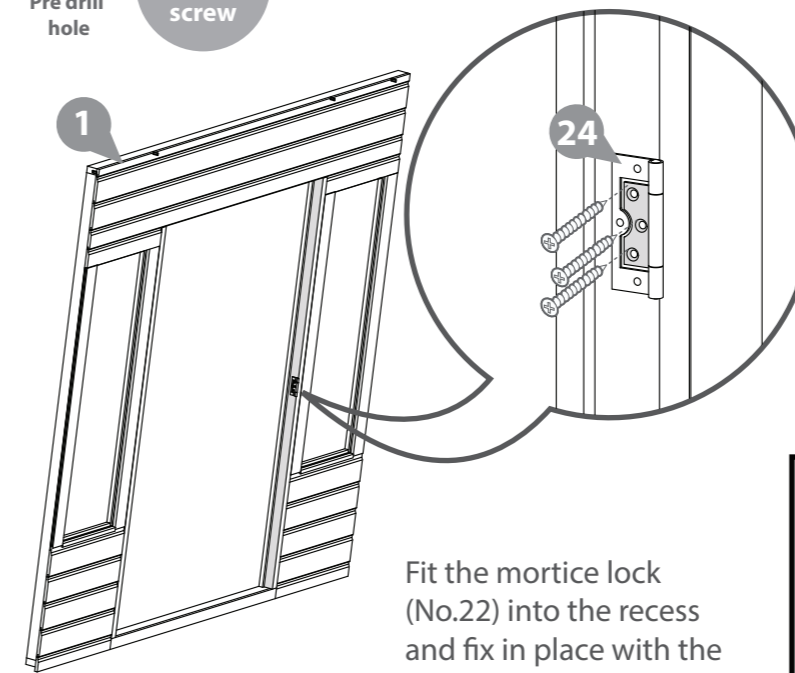

Fit the mortice lock (**No.22**) into the recess and fix in place with the screws provided. Fit the key plate (**No. 23**) to the opposite door using the screws provided.

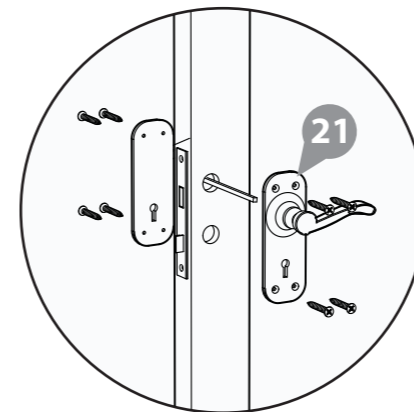
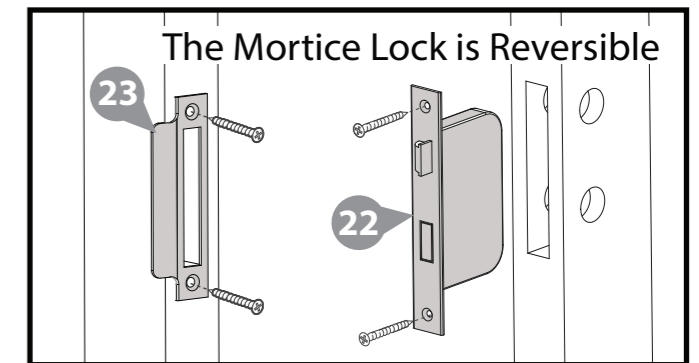

Fix the door handles (**No.21**) and the metal bar (spindle) using 8x30mm screws. Ensure the mortice lock closes correctly. If not, remove lock and turn the catch around using the small grub screw.

8x30mm screws



Step 2 Continued...

Fix the door bar (No. 20) to the inside of the slave door using 6x30mm screws as shown in the illustration.

6x30mm screws



Fit the door beading (No. 14) to the inside of the door frame using 8x30mm screws, ensuring that they sit flush with the frame and the door.

8x30mm screws



Attach the tower bolts (No. 26) to the door bar using 12x30mm screws.

12x30mm screws

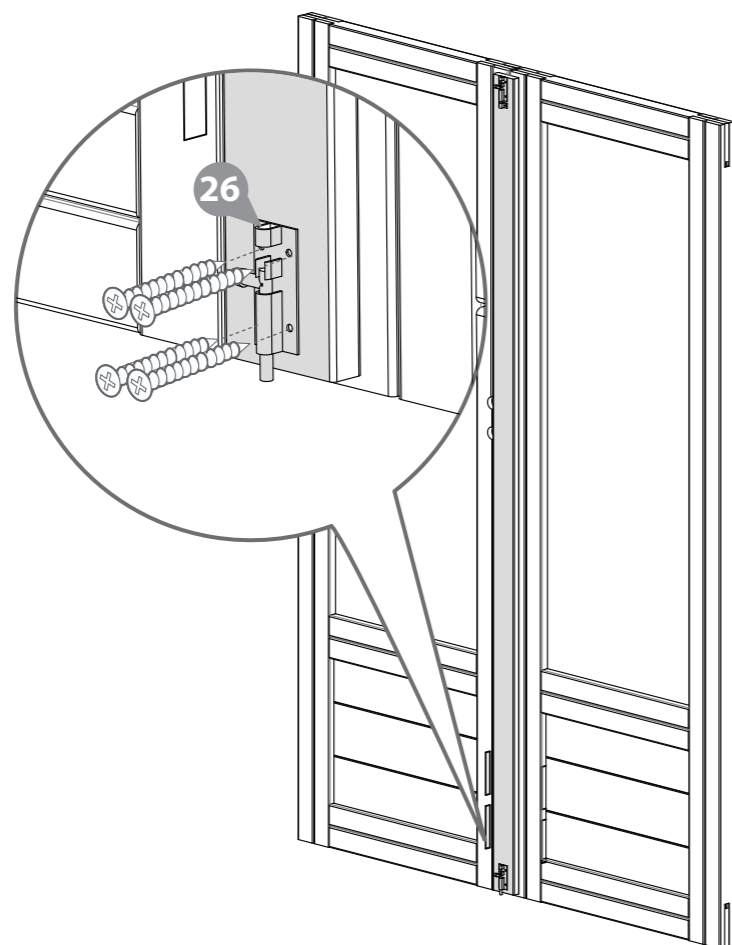
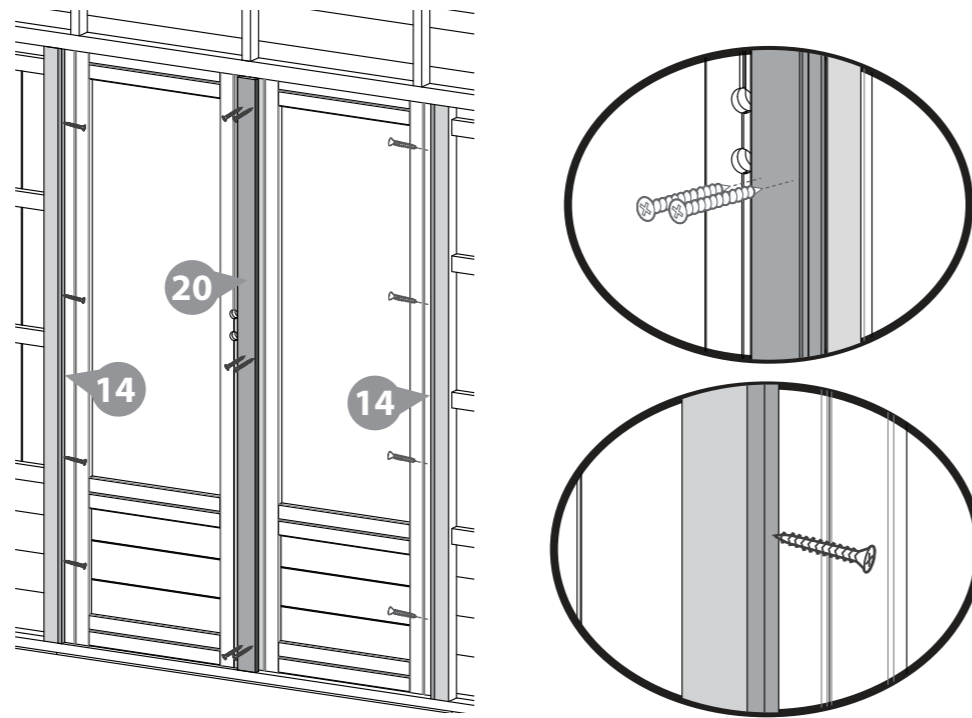
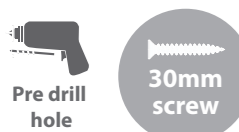

Step 3

Place the back panel (No. 4) and the right gable (No. 2) onto the floor.

- a Fix the two panels together at the corners using 3x50mm screws.
- b Do **NOT** secure the building to the floor until the roof is fitted.

3x50mm Screws

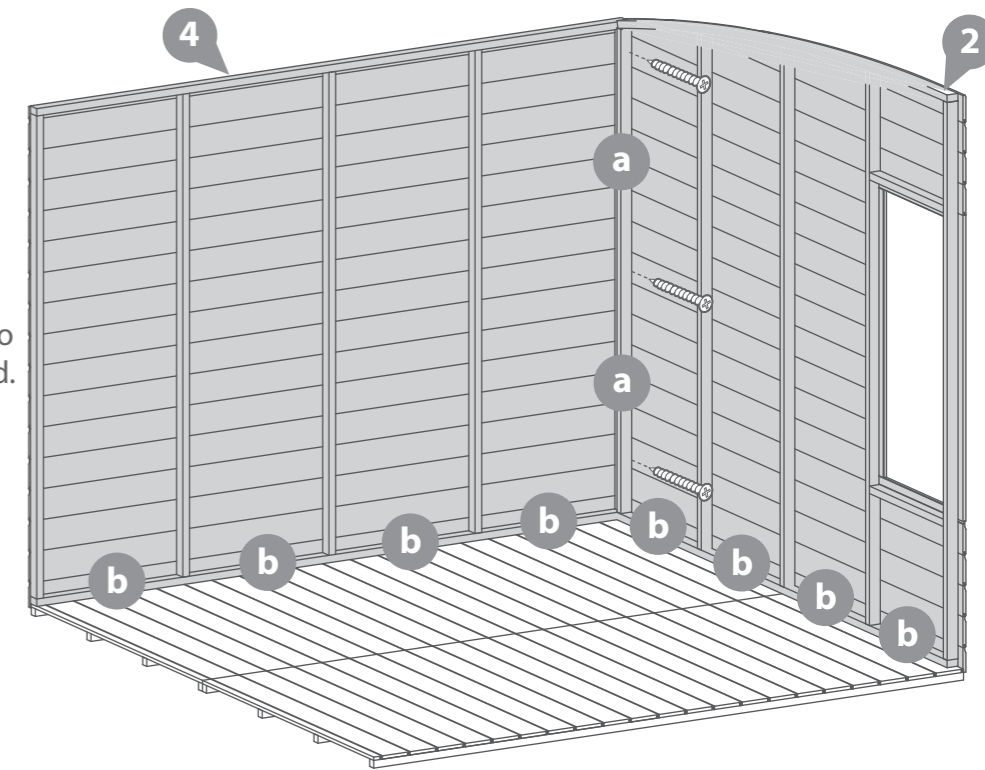
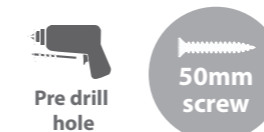

Step 4

Following the same method outlined in step 3, place the left gable (No. 3) onto the floor against the back panel.

- a Fix the two panels together at the corners using 3x50mm screws.
- b Do **NOT** secure the building to the floor until the roof is fitted.

3x50mm Screws

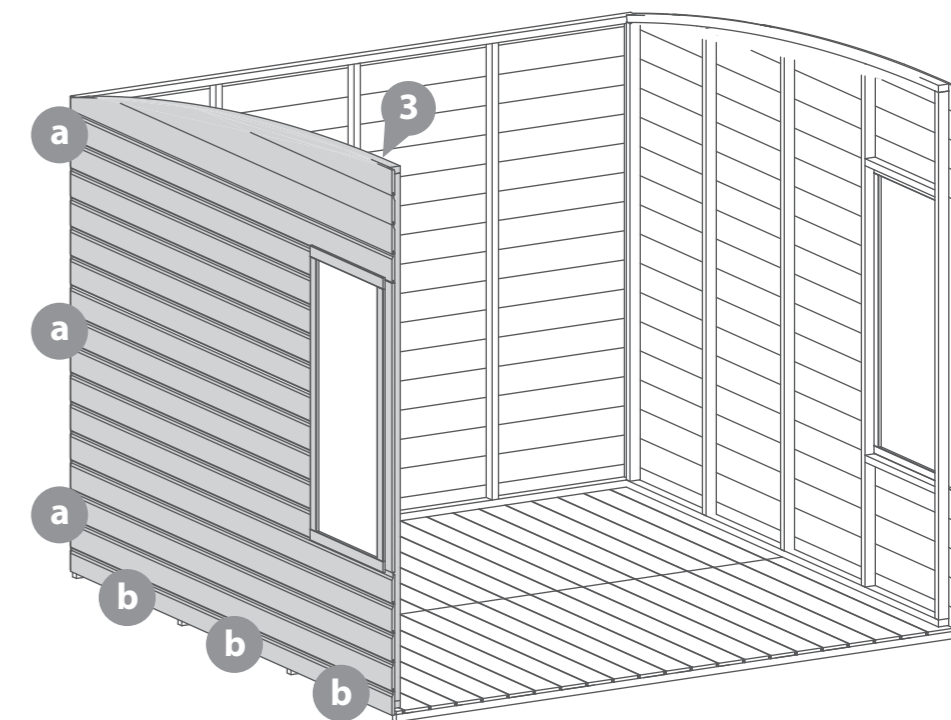

Step 5

Following the same method outlined in step 3, place the assembled door panel onto the floor inbetween the gables.

- a** Fix the panels together at the corners using 3x50mm screws per side.

Do **NOT** secure the building to the floor until the roof is fitted.

6x50mm Screws

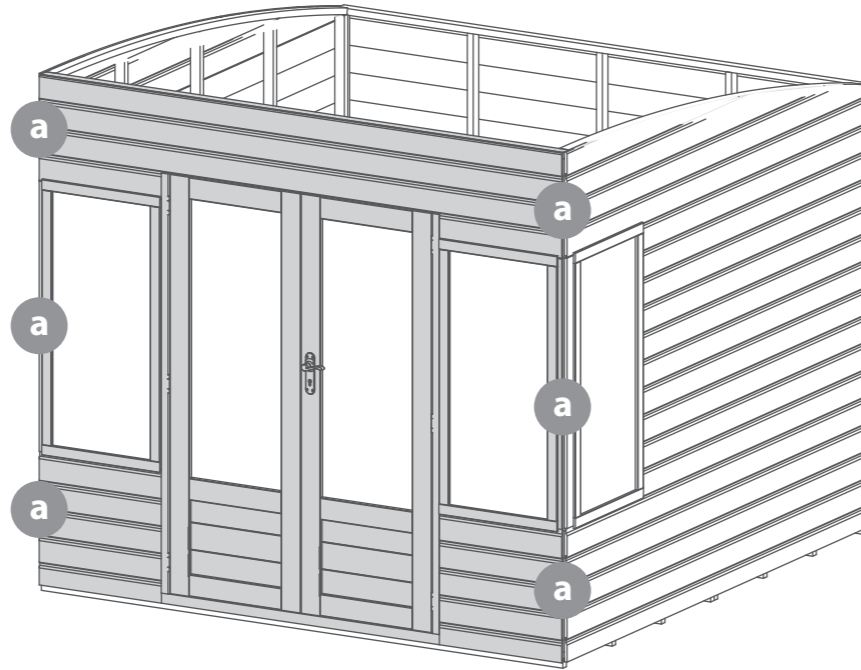

Step 6

- a** Place the first ridge bar (No.9) inside the building and line up with the upright framing on each gable.

Align the back edge of the ridge bar with the top of the gable. Once in place mark the position on both sides with a pencil.

Place the roof support block (No. 10) to the pencil mark and secure in place using 2x40mm screws per block.

*Repeat this process on both sides with the remaining roof support bars.

- b** Place the ridge bar(s) on top of the attached blocks and secure through the outside of both gables using 2x80mm screws per side.

12x40mm Screws
12x80mm Screws

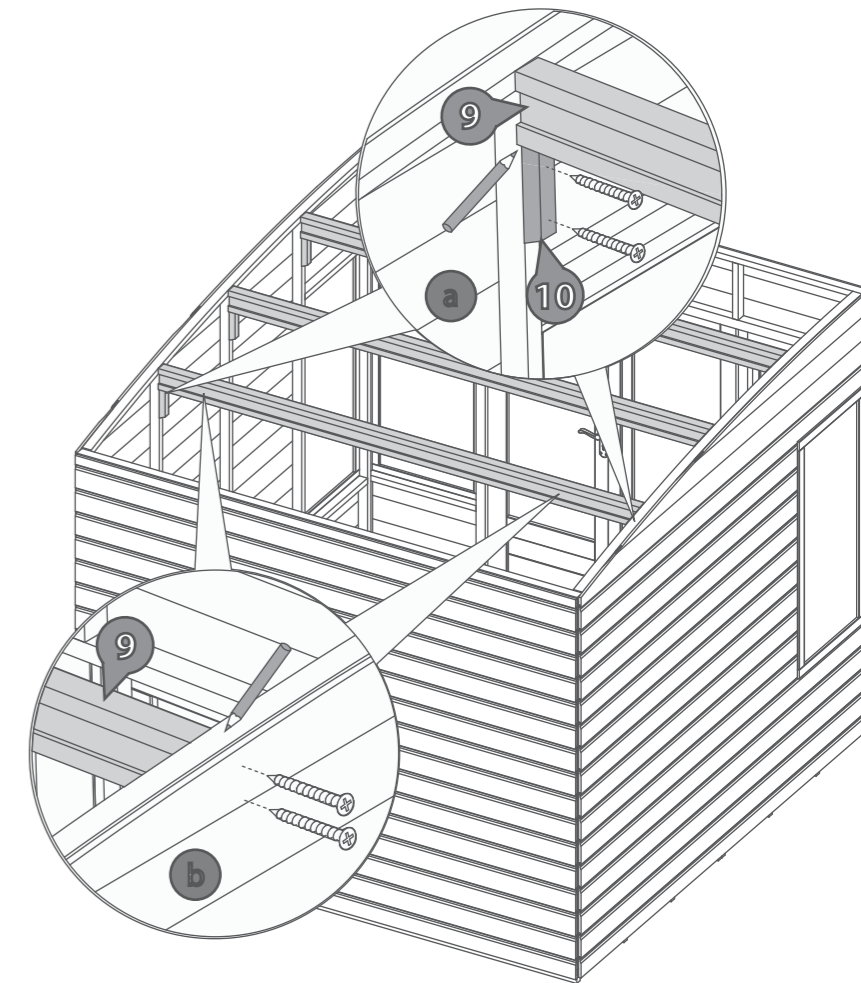

***Hint: When fitting the roof bar pencil mark the centre of the roof support bar and follow down onto the gable at a right angle, this will give you a guide to fix the support bars in place.**

Step 7

Place the first roof panel (No. 6) onto the supports (making sure the roof framing sits behind the support bar) and secure with 20x40mm screws as shown in the diagram. Ensure the screws line up with the roof support bars.

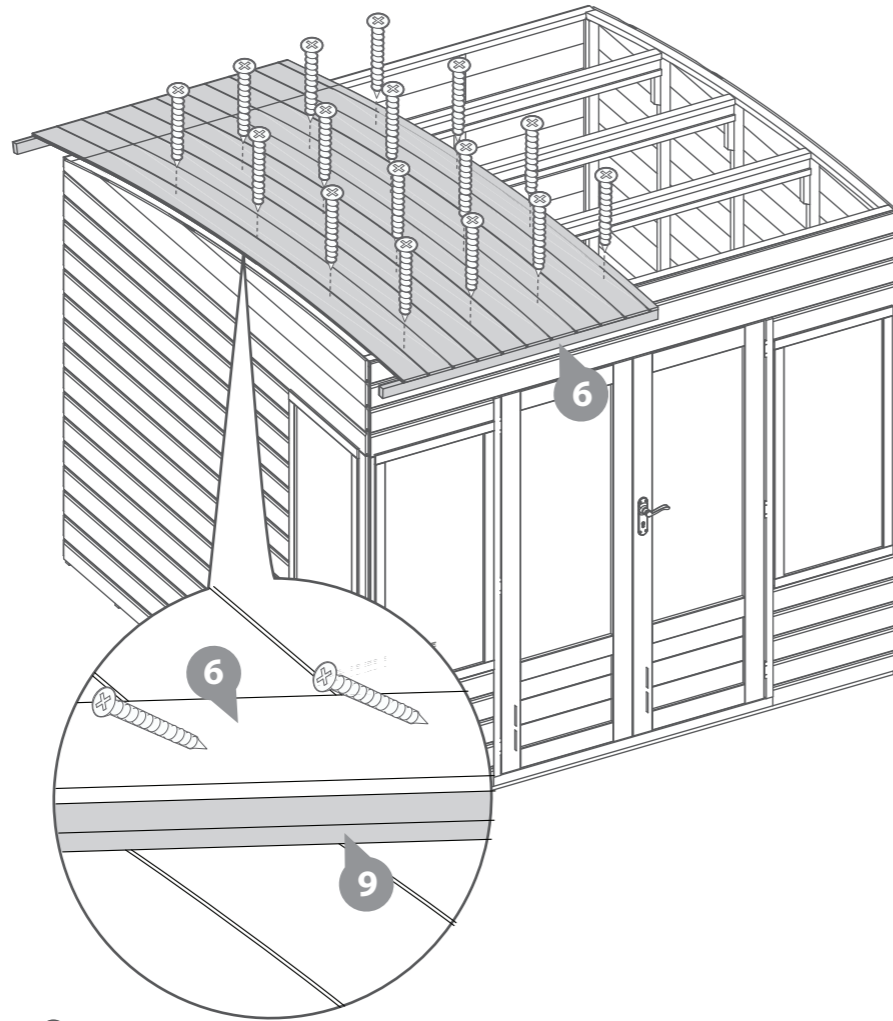

20x40mm Screws



Fix the roof bar to the supports where they meet (internally) using 8x40mm screws.

8x40mm Screws

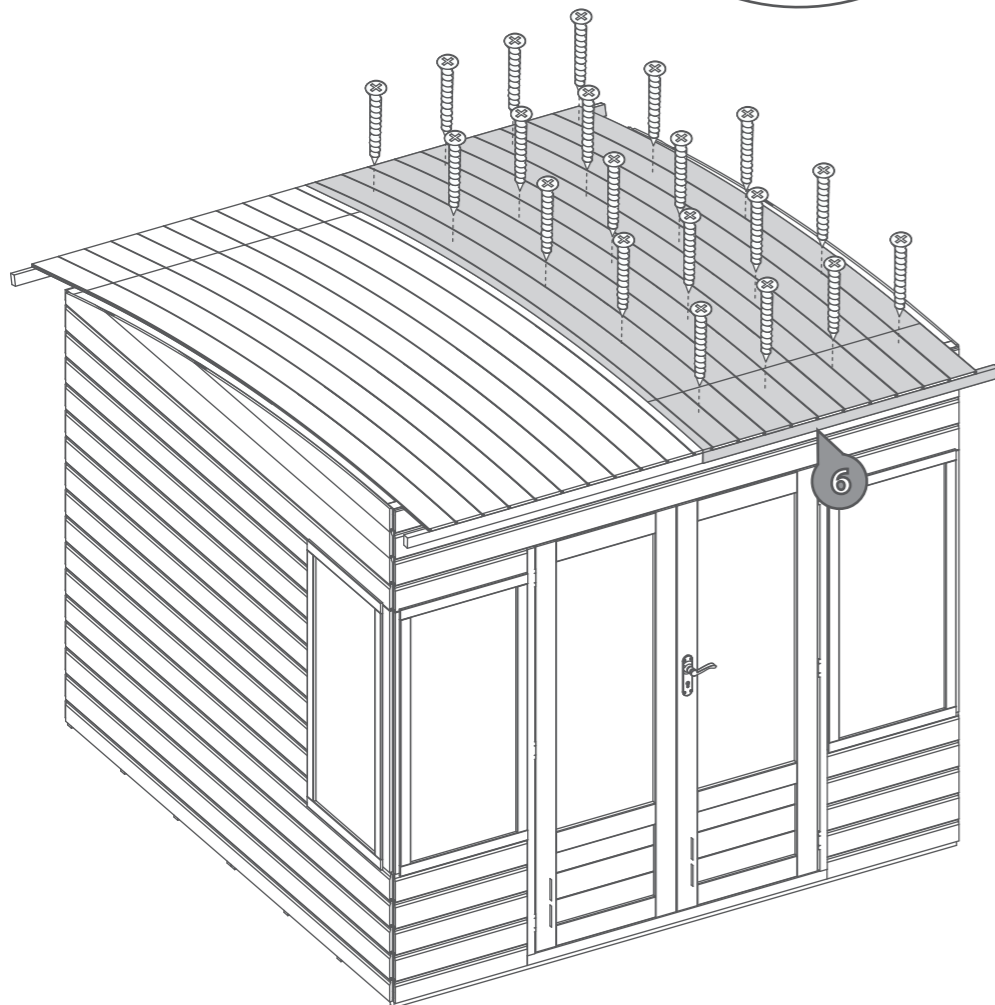

**Repeat this process with the second roof panel.*

28x40mm Screws

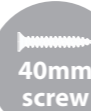

Step 8

Position the roof ends (No. 13) onto the roof, ensuring the tongue and groove align and the boards sit flush together.

Secure each board to the gable framing using 6x30mm screws.

12x30mm Screws

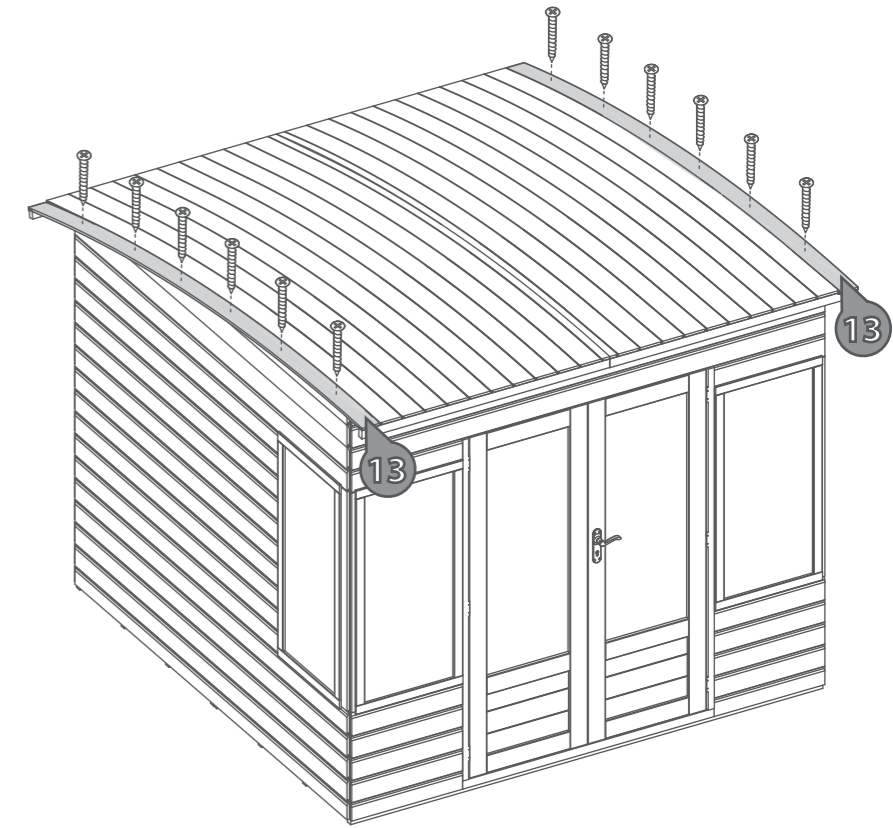
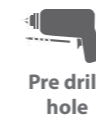

Step 9

b Secure the building to the floor using 36x50mm screws.

36x50mm Screws



**Ensure to align the screws with the floor bearers.*

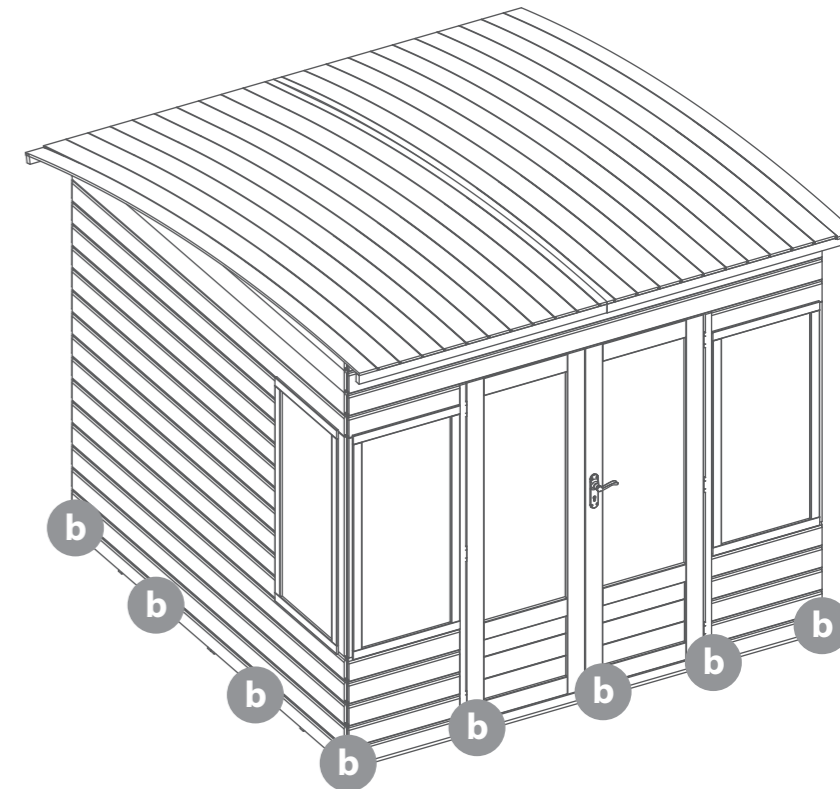

Step 10

Cut the felt into 4x strips and lay onto the roof in the order shown in the illustration, leaving approximately 50mm of overhanging felt around the building.

Secure the felt to the building with 165x felt tacks at 100mm intervals

165x Felt Tacks

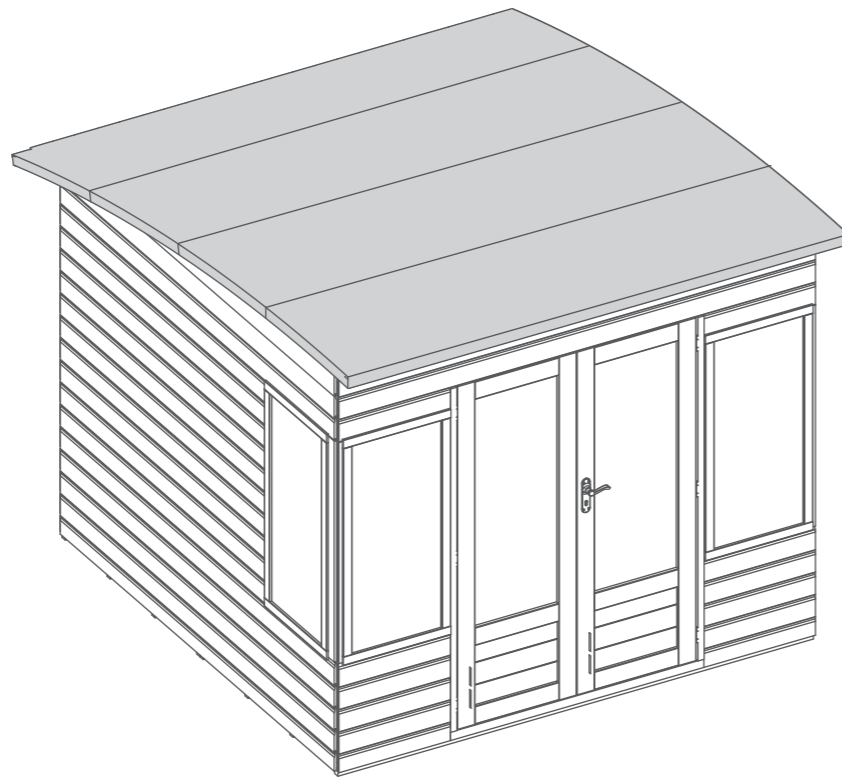
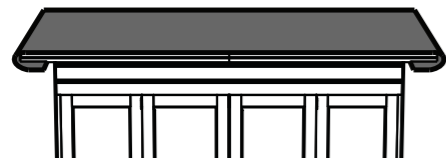

*Felt size: 2606mm

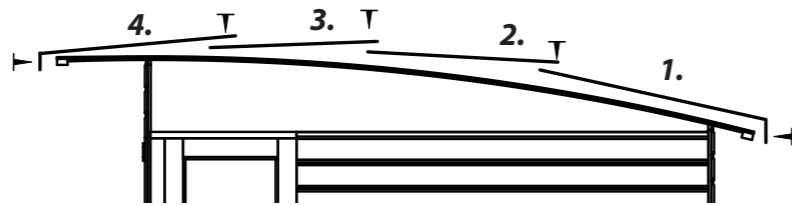
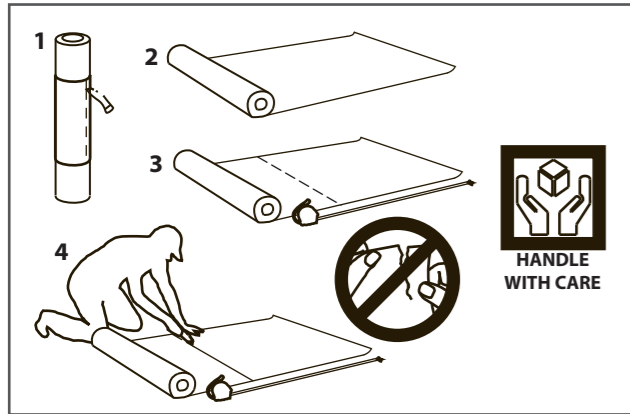

Step 12

Fix the fascia's (No. 17) to the front of the building using 4x40mm screws.

Attach the finial (No. 27) over the join in the fascia's with 2x40mm screws.

10x40mm Screws

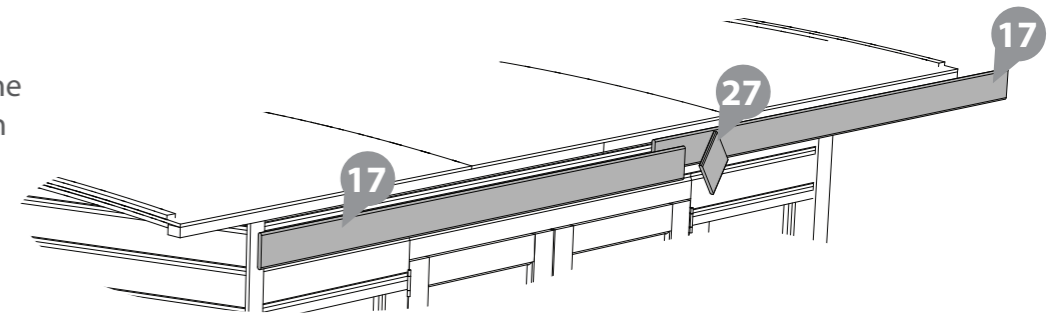
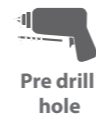

Step 13

Attach the front (No. 18) and rear (No. 19) cover trims to the building, fixing each trim using 3x30mm screws.

12x30mm Screws

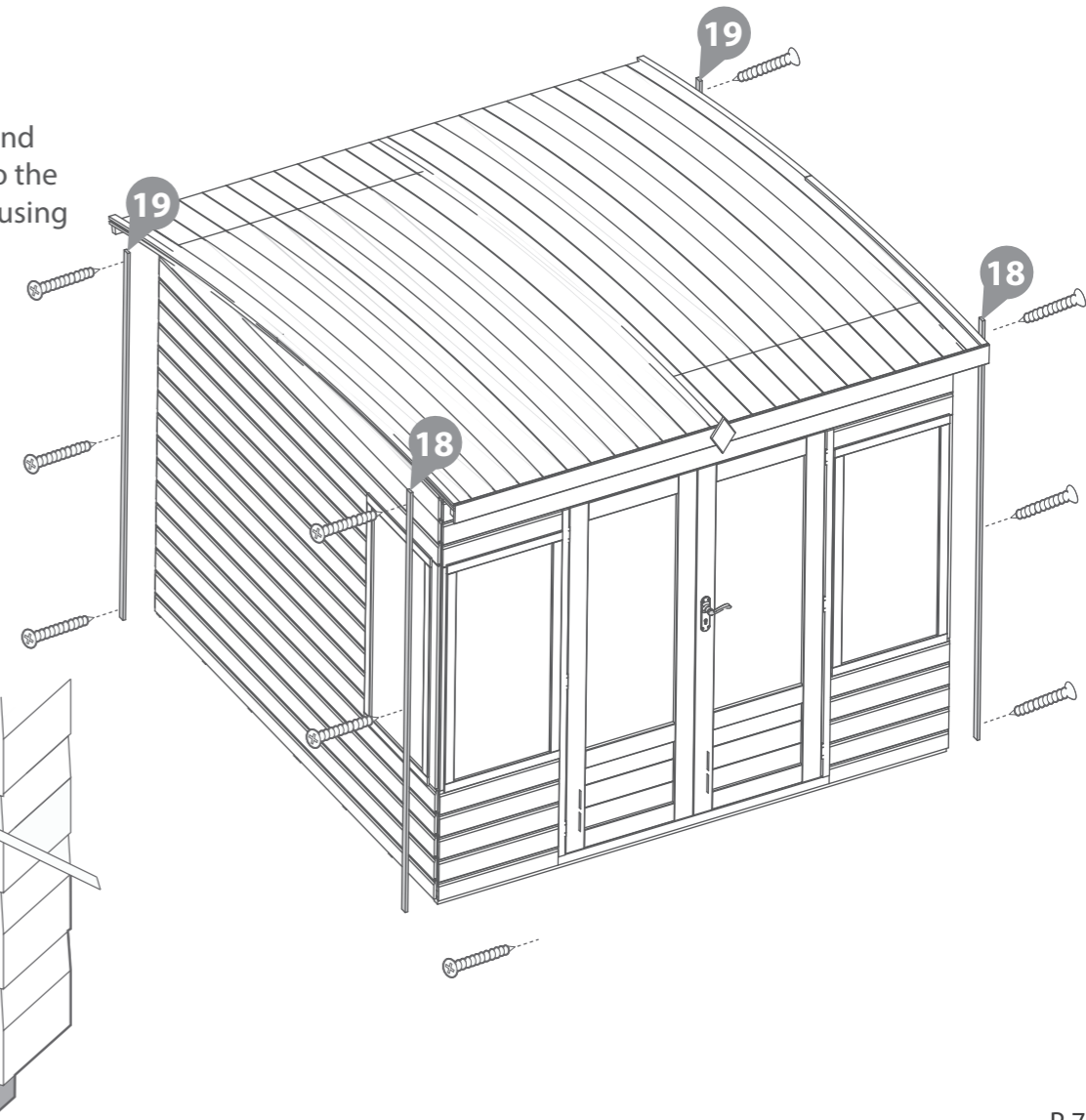

Step 11

Sandwich the felt either side between the roof and the top (No. 16) and bottom (No. 15) roof trims, fixing each strip to the roof with 3x30mm screws

24x30mm Screws

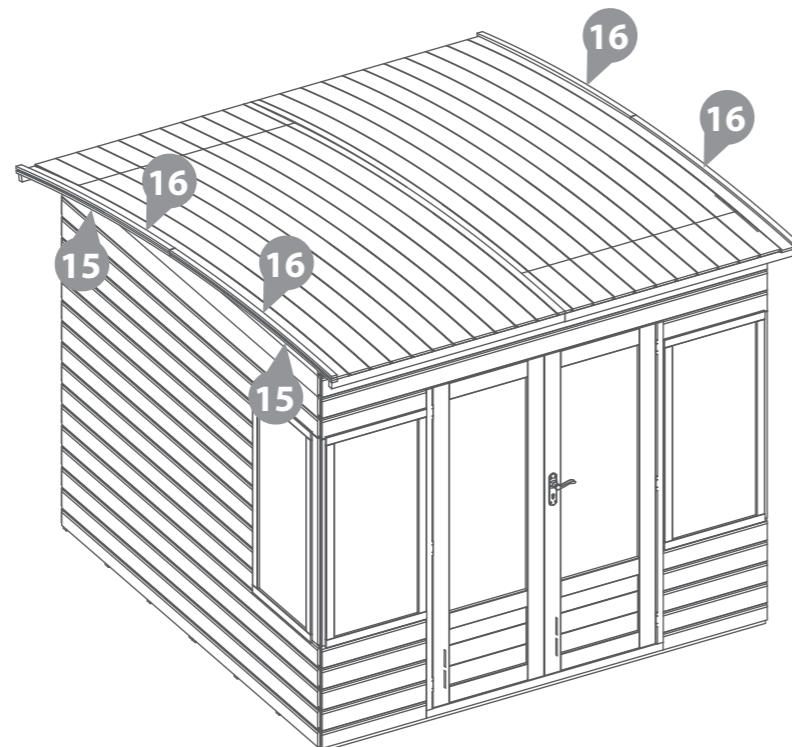
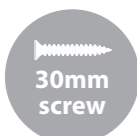

Step 14

Fix the turn button's (No. 25) to the top and bottom of the slave door using 2x 30mm black screws.

2x30mm Black Screws

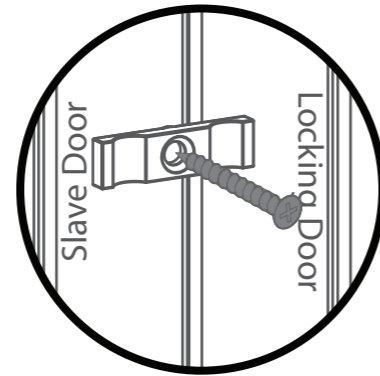

*These turn buttons help keep your doors straight during high and low levels of moisture content in the air.

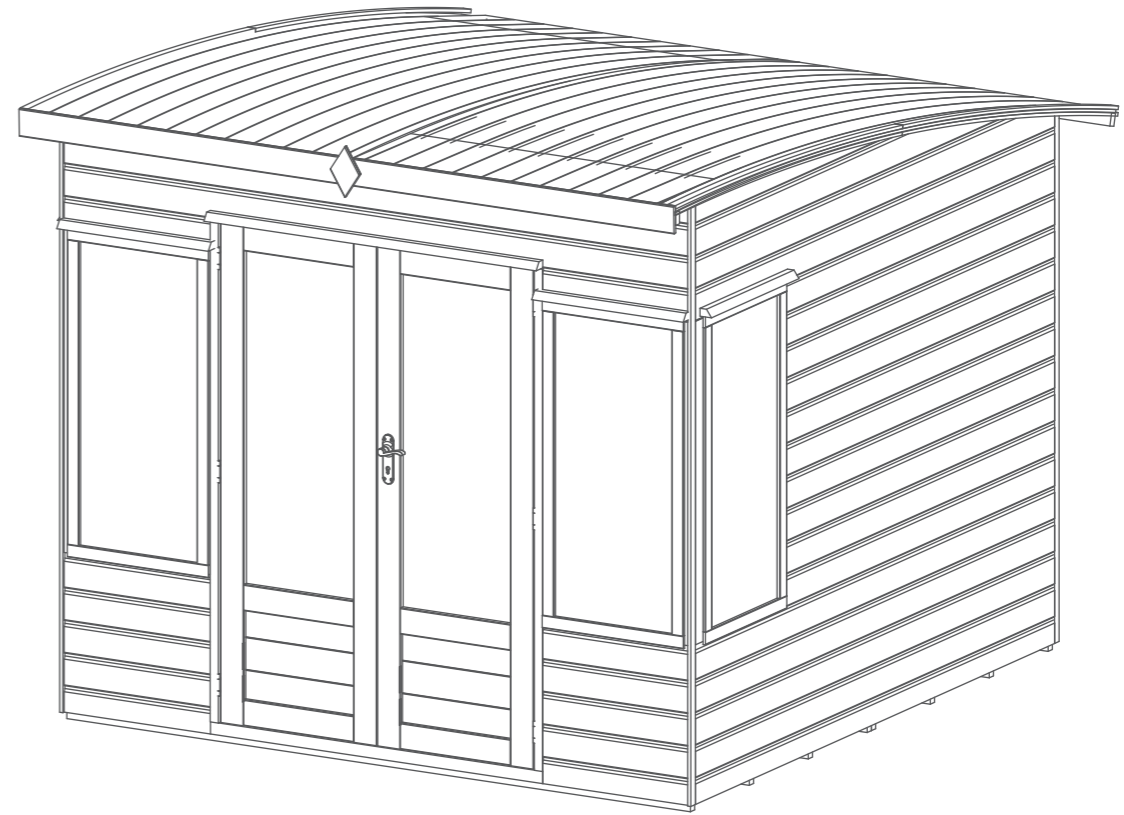

Step 15

Fix the large rain guard (No. 11) above the door using 4x50mm screws.

Attach the small rain guards (No.12) above each window using 3x50mm screws per sml rain guard.

16x50mm Screws

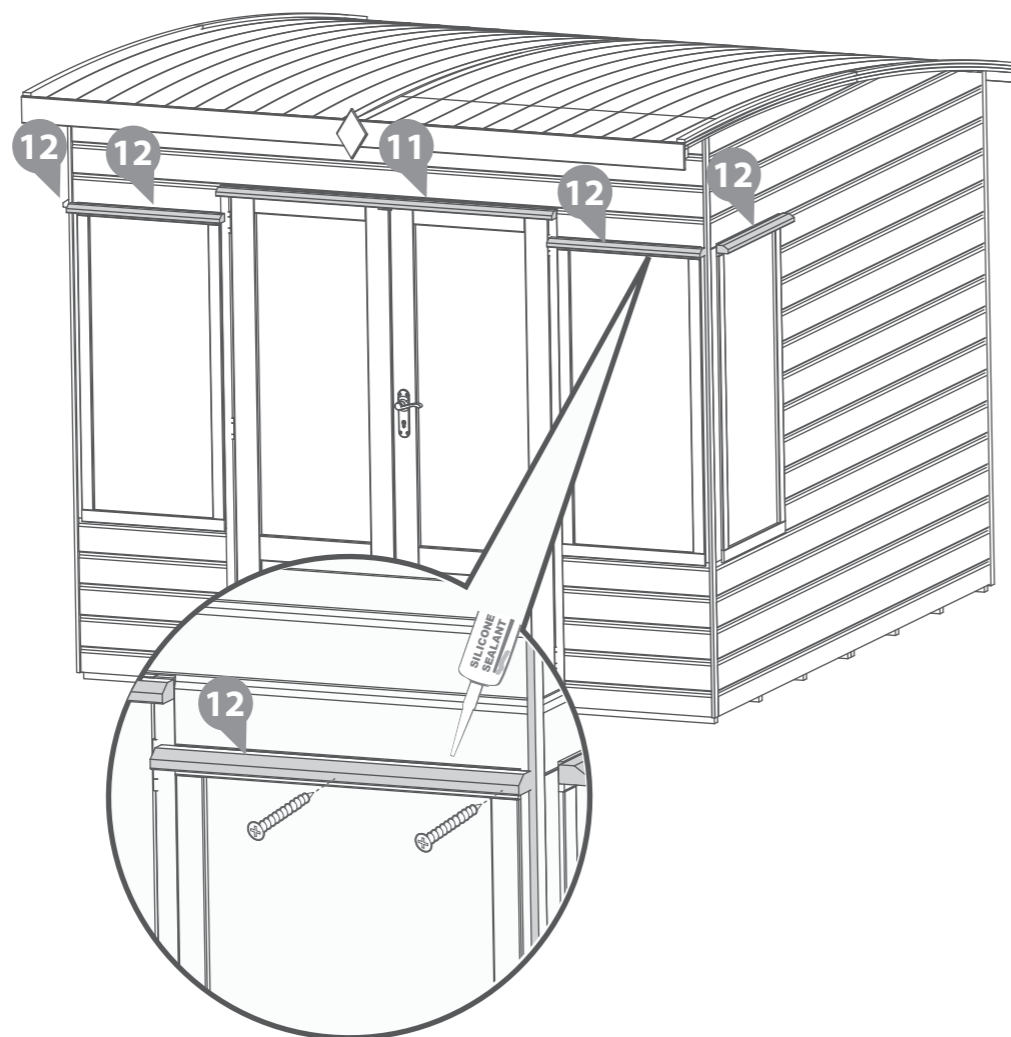

*Seal each rain guard with silicone sealant before fixing to the building.



It is **ESSENTIAL** that you apply wood treatment immediately after the building has been assembled.

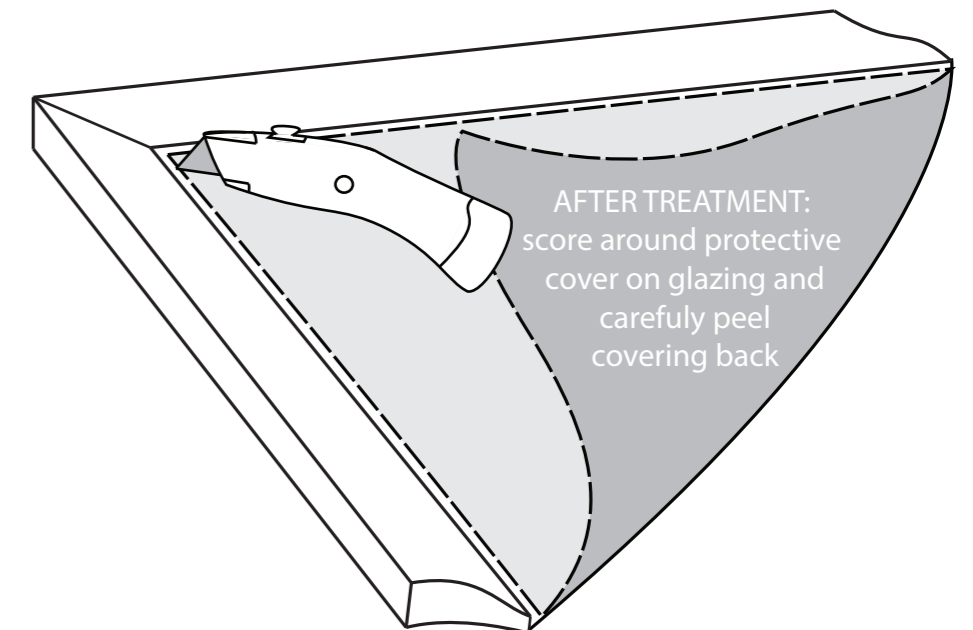

AFTER TREATMENT: score around protective cover on glazing and carefully peel covering back