

03VER1008-V2

10x8 Vermont Summerhouse

BEFORE YOU START PLEASE READ INSTRUCTIONS CAREFULLY

- Check the pack and make sure you have all the parts listed.
- When you are ready to start, make sure you have the right tools at hand (not supplied) including a Phillips screwdriver, Stanley knife, Wood saw, Step ladder, Hammer and a Drill with 2mm bit.
- Ensure there is plenty of space and a clean dry area for assembly.

TIMBER

As with all natural materials, timber can be affected during various weather conditions. For the duration of heavy or extended periods of rain, swelling of the wood panels may occur. Warping of the wood may also occur during excessive dry spells due to an interior moisture loss. Unfortunately, these processes cannot be avoided but can be helped. It is suggested that the outdoor building is sprayed with water during extended periods of warm sunshine and sheltered as much as possible during rain or snow.

Once your garden building has been installed it will need to be treated as soon as possible and annually to prevent the timber from deteriorating and to waterproof it. This is required to maintain the anti-rot guarantee.

Dip Treated buildings - Require a preservative treatment to protect against rot and decay and a waterproof treatment to prevent water ingress

Pressure Treated buildings - Require a waterproof treatment to prevent water ingress

Log Cabins - Are supplied untreated and require a preservative and waterproofing treatment.

BUILDING A BASE

When thinking about where the building and base is going to be constructed: Ensure that there will be access to all sides for maintenance work and annual treatment.

Ensure the base is level and is built on firm ground, to prevent distortion. Refer to diagrams for the base dimensions, The base should be slightly smaller than the external measurement of the building, i.e. The cladding should overlap the base, creating a run off for water. It is also recommended that the floor be at least 25mm above the surrounding ground level to avoid flooding.

TYPES OF BASE

- Concrete 75mm laid on top of 75mm hard-core.
- Slabs laid on 50mm of sharp sand.

Whilst all products manufactured are made to the highest standards of Safety and in the case of childrens products independently tested to EN71 level, we cannot accept responsibility for your safety whilst erecting or using this product.

Refer to the instructions pages for you specific product code



x2

All buildings should be erected by two adults



Winter = High Moisture = Expansion
Summer = Low Moisture = Contraction



2mm Drill bit

For ease of assembly, you **MUST** pilot drill all screw holes and ensure all screw heads are countersunk.



CAUTION

Every effort has been made during the manufacturing process to eliminate the prospect of splinters on rough surfaces of the timber. You are strongly advised to wear gloves when working with or handling rough sawn timber.



For ease of assembly, you will need a tape measure to check dimensions of components.

****Protim Aquatan T5 (621)****

Your building has been treated with **Aquatan**

Aquatan is a water-based concentrate which is diluted with water, the building as been treated by the correct application of Aquatan solution and then allowed to dry.

Aquatan is a decorative finish to colour the wood, which is applied industrially to timber fence panels and garden buildings.

Aquatanundiluted contains:boric acid, sodium hydroxide 32% solution, aqueos mixture of sodium dioctyl sulphosuccinat and alcohols: 2, 4, 6-trichlorophenol.

For assistance please contact customer care on: 01636 880514

**Mercia Garden Products Limited,
Sutton On Trent,
Newark,
Nottinghamshire,
NG23 6QN**

www.mercia garden products.co.uk



Overall Dimensions:

Length = 3028mm
Width = 2484mm
Height = 2569mm

Base Dimensions:

Length = 2974mm
Width = 2360mm

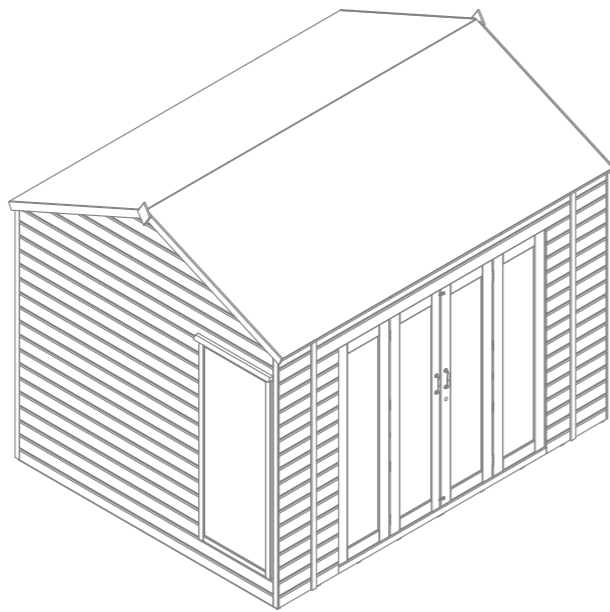

1

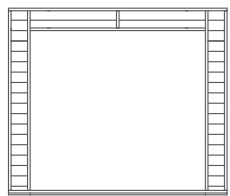

Door Panel

AI-03VERDP2360X2015-V1

2



Sm Panel QTY 2

AI-03VERSMP310X2015-V1

3

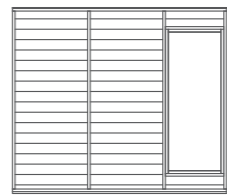

Window Panel Right

AI-03VERWPR2310X2007-V1

4

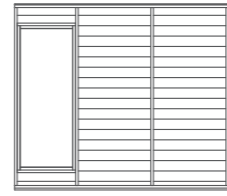

Window Panel Left

AI-03VERWPR2310X2007-V1

5

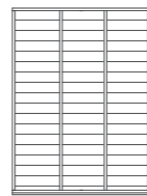

Back Panel QTY 2

AI-03VERBP1490X2015-V1

6

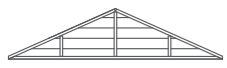

Gable Top QTY 2

AI-03VERGT2310X546-V1

7

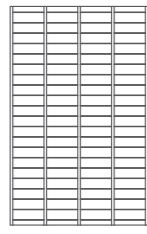

Floor QTY 2

AI-01TAGF2360X1487-V1

8



Roof Sheet QTY 4

PI-03-0290

9



Master Door

AI-03FGMD1720X475-V1

10



Slave Door

AI-03FGD1720X475-V1

11



Side Door QTY 2

AI-03FGSD475X1720-V1

12

Ridge Bar - 27x70x1462mm QTY 2

F2770-1462

13

Eaves Frame - 28x28x1001mm QTY 6

FS2828-1001

14

Roof Support Bar - 27x44x1262mm QTY 6

F2744-1302

15

Roof Support Brace - 27x44x450mm QTY 3

F2744-490

16

Cover Trim - 12x40x1976mm QTY 7

S1240-1976

17

Fascia - 12x60x1333mm QTY 4

S1260-1333

18

Finial QTY 2

SHED DIAMOND FINIAL

19

Rain Guard - 28x44x680mm QTY 2

RG2844-680

20

Butt Hinge QTY 14

PI-07-0066

21



Turn Button QTY 2

PI-07-0034

22



"L" Bracket QTY 2

PI-07-0012

23



Door Handle QTY 2

PI-07-0081

24

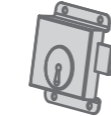

Press Lock

PI-07-0162

25



Barrel Bolt QTY 6

PI-07-0114

26

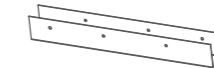

"U" Channel

PI-07-0013

27



Roof Support Block - 27x44x140mm QTY 6

F2744-160

28



Door strip- 12x60x720mm QTY 2



S1260-1720



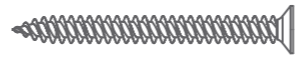

29

Door Support Bar - 27x44x2924mm QTY 1

F2744-2924

Nail Bag

-  35mm Bolt QTY 4
-  70mm Screw QTY 6
-  50mm Screw QTY 105
-  40mm Screw QTY 20

-  30mm Screw QTY 147
-  30mm Black Screw QTY 2
-  25mm Screw QTY 72
-  10mm Screw QTY 36
-  Felt Tacks QTY 132

Pre Assembly

Remove the transportation blocks from the bottom and top of each panel before beginning assembly

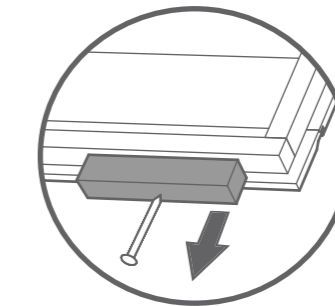

Step 1

Attach the side doors to the inside framing of the door panel using 3x butt hinges per door.

** Fix to the door using 3x25mm screws & 3x30mm screws to the framing per hinge, ensure the doors open freely, folding back into the building unrestricted.*

18x25mm Screws
18x30mm Screws



Pre drill hole

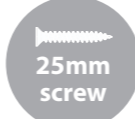

25mm screw



30mm screw

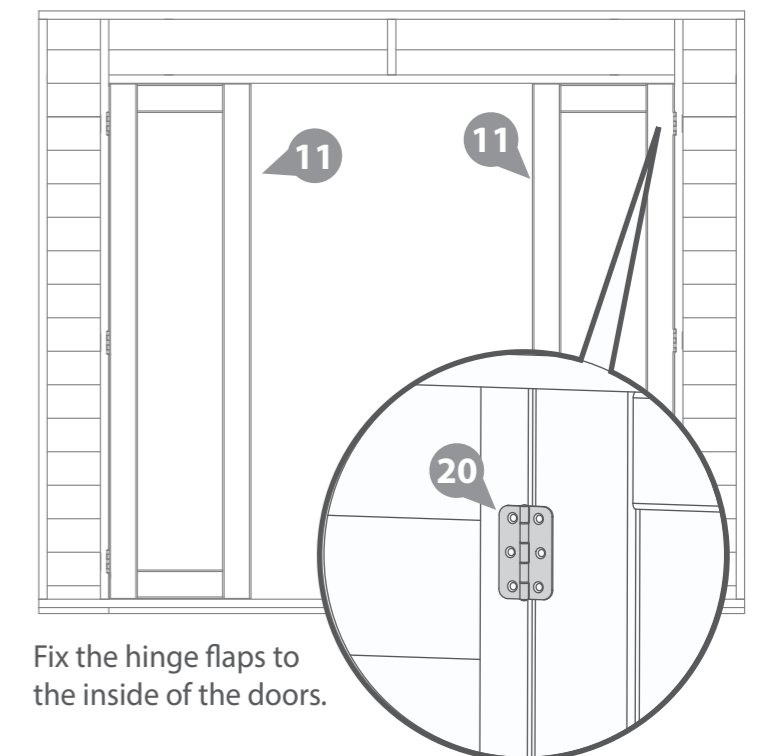

Fix the hinge flaps to the inside of the doors.

Step 2

Fix the master and slave door to the attached side doors with 8x butt hinges, using 6x25mm screws per hinge.

**Ensure the doors open freely, folding back into the building unrestricted.*

48x25mm Screws

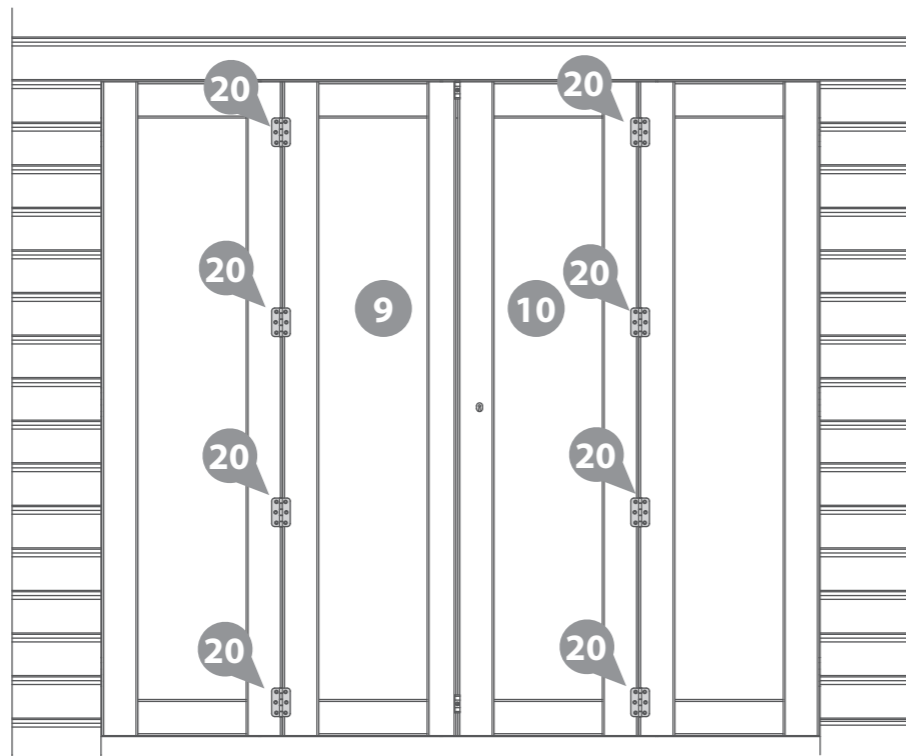

Step 3

Secure the barrel bolts to the top & bottom of each side door and the slave door using 6x10mm screws.

Attach the press lock to the master door with 4x25mm screws, aligning the barrel with the key hole.

**Ensure the key turns and locks properly before fixing to the door.*

Fix the door handles to the outside of the master and slave door using the 35mm bolts provided.

36x10mm Screws 4x25mm Screws 4x35mm Bolts

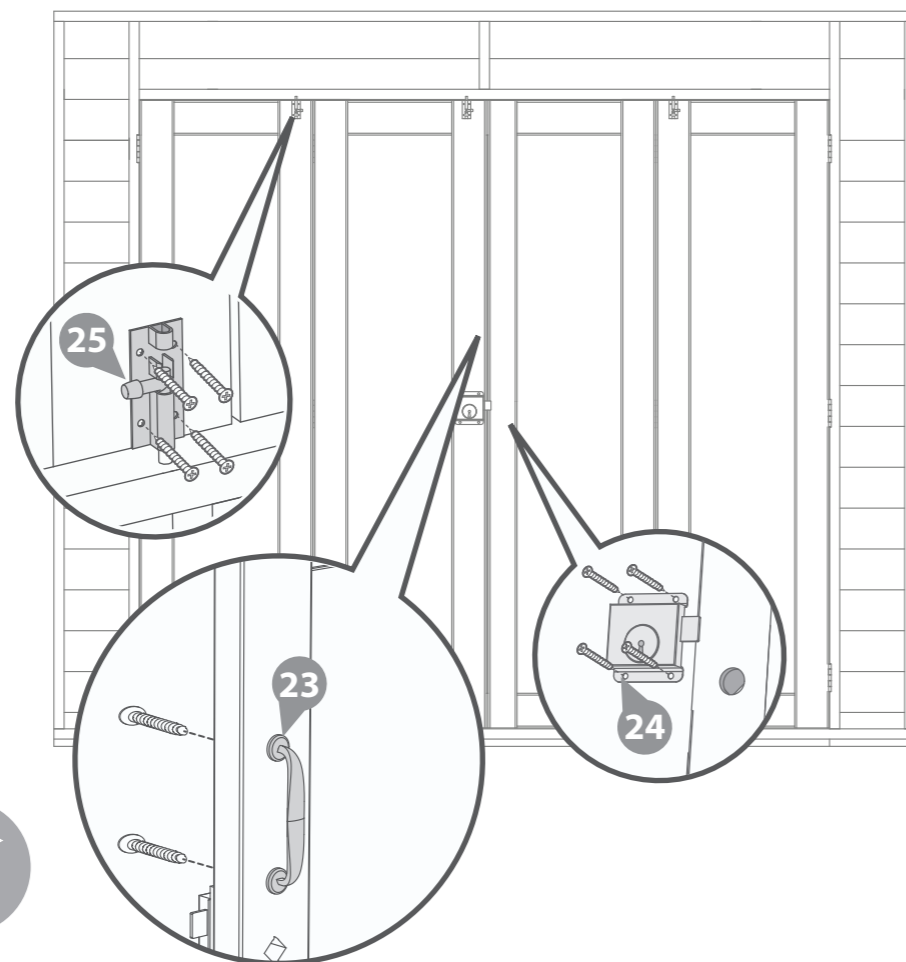

Step 4

Place the floor panels upside down onto a firm and level base. Ensure the base has suitable drainage, free from areas where standing water can collect.

Secure the floors together using 8x50mm screws through the floor bearers in an alternating pattern.

Once fixed together turn the floor back the right way up.

8x50mm Screws

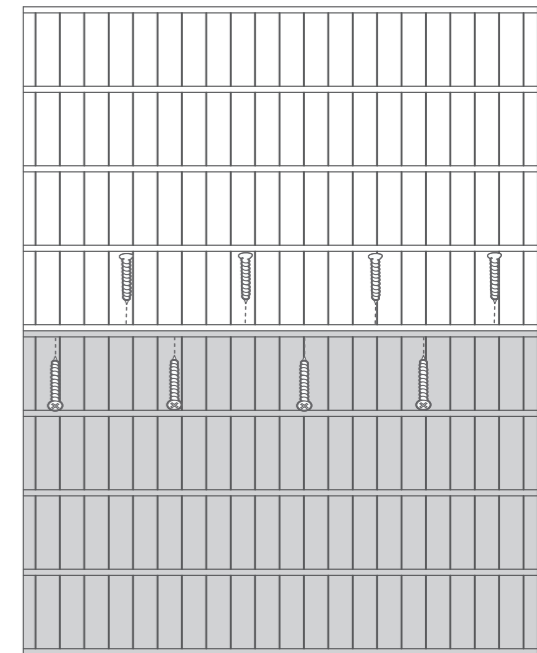
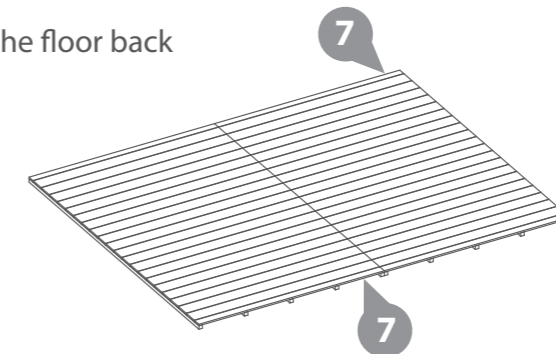

Step 5

a Fix the corners with 50mm screws as shown in the illustration.

b Do **not** secure the building to the floor until the roof is fitted.

3x50mm Screws

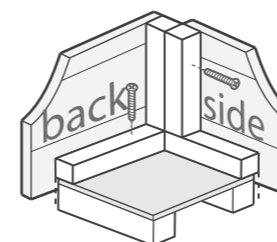
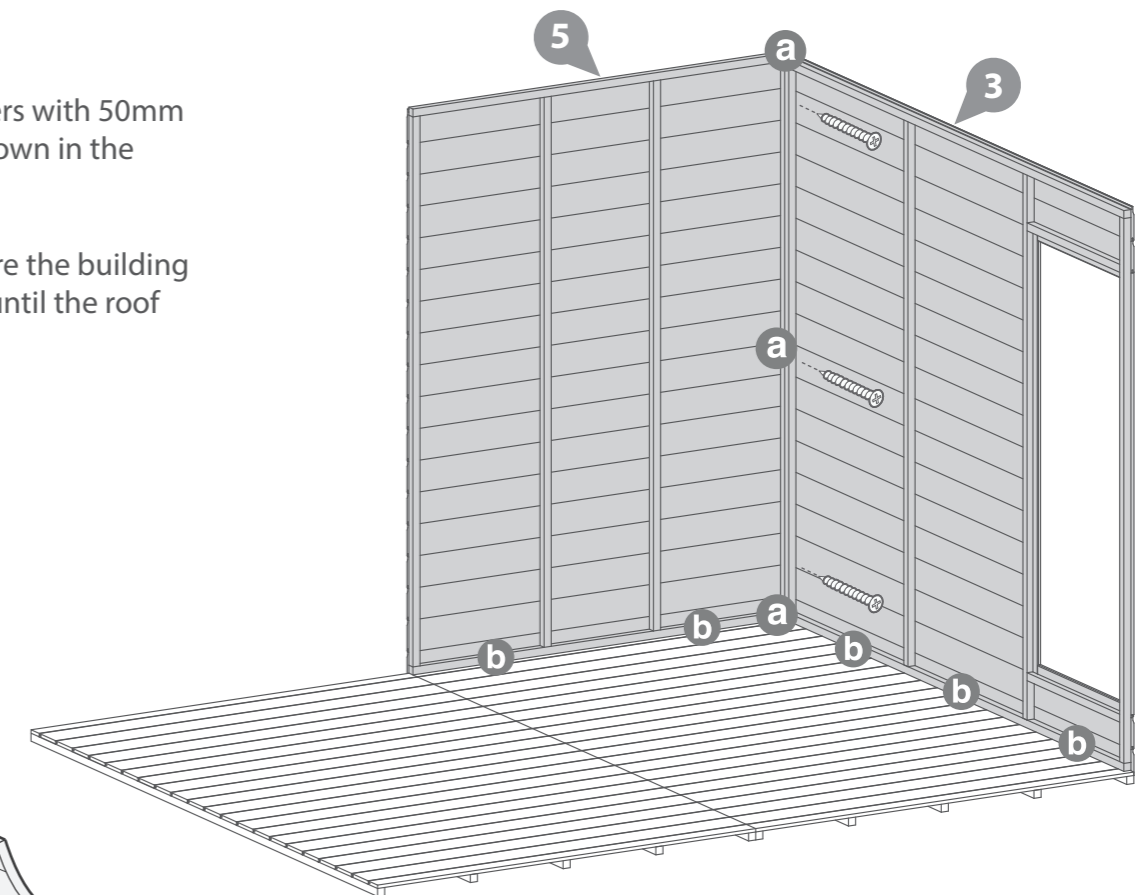

Step 6

- a** Fix the corners with 50mm screws as shown in the illustration.
- b** Do **not** secure the building to the floor until the roof is fitted.

9x50mm Screws

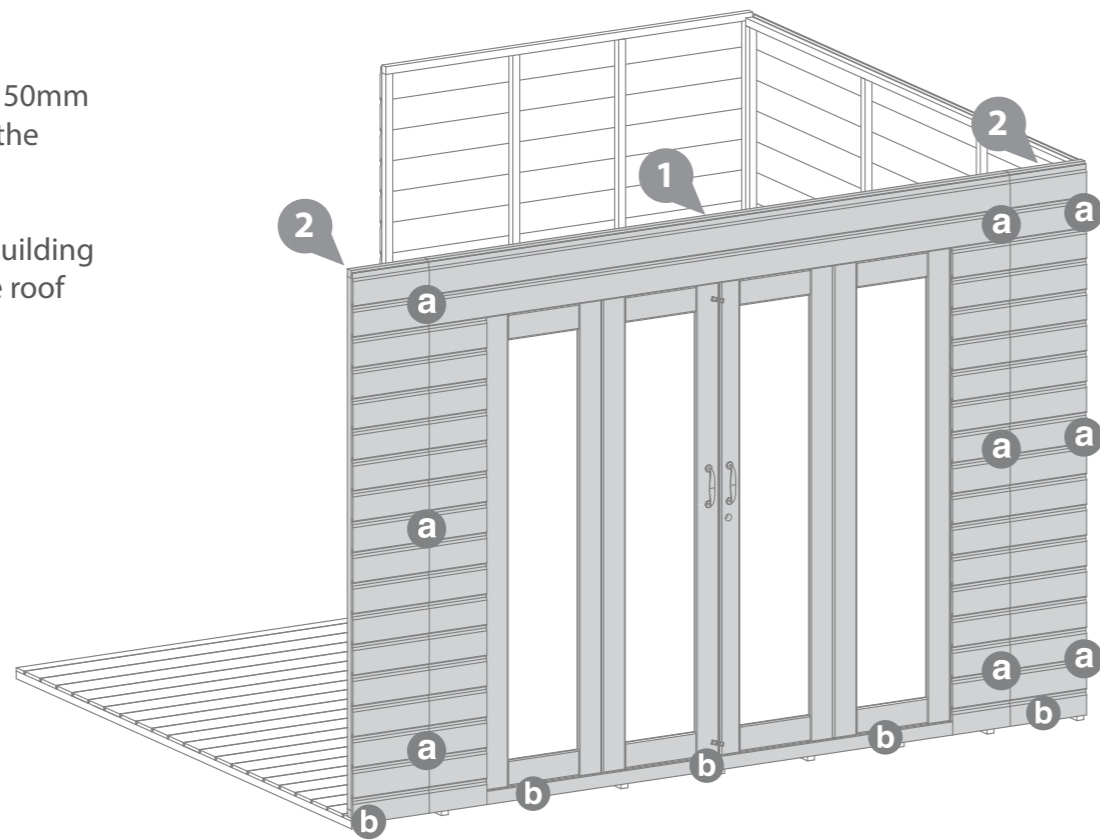
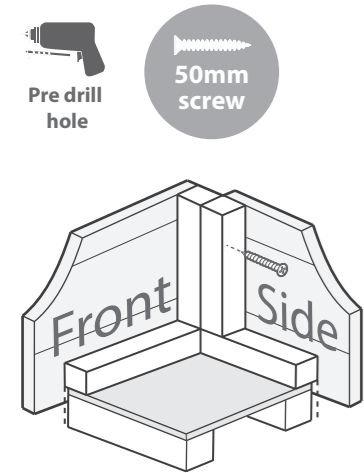

Step 7

- a** Fix the corners with 50mm screws as shown in the illustration.
- b** Do **not** secure the building to the floor until the roof is fitted.

9x50mm Screws

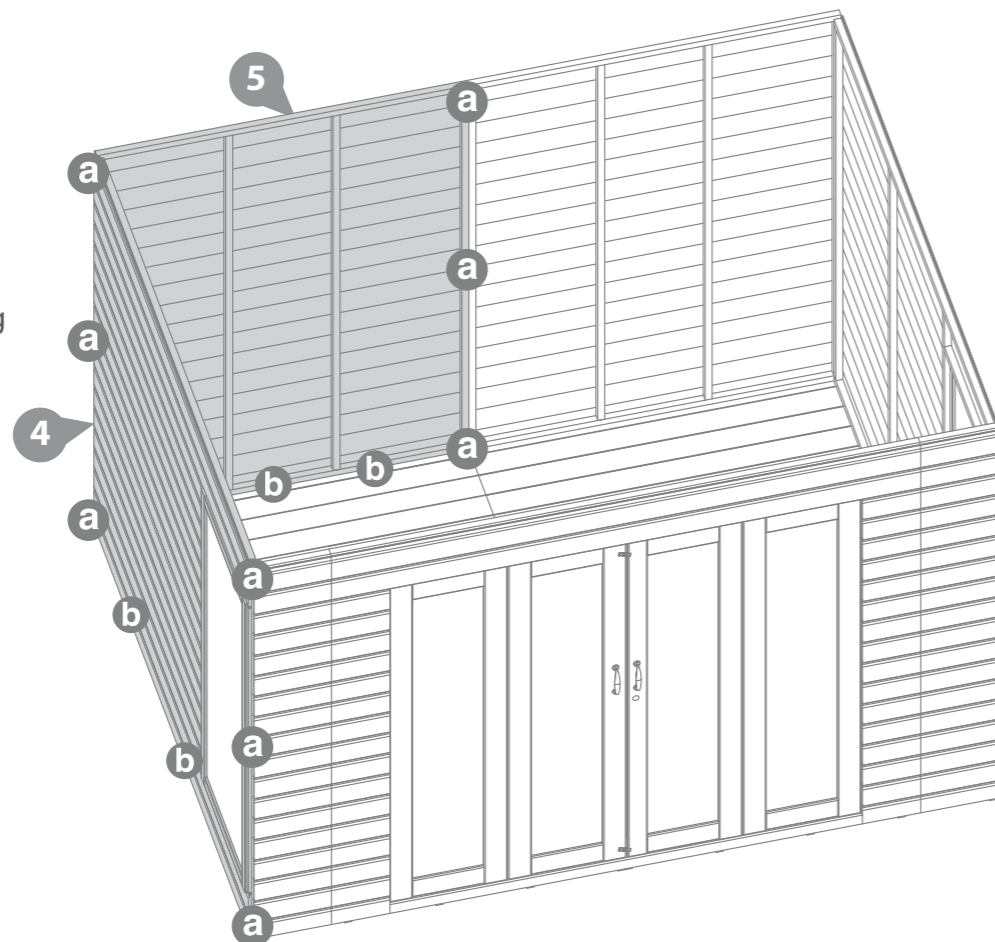
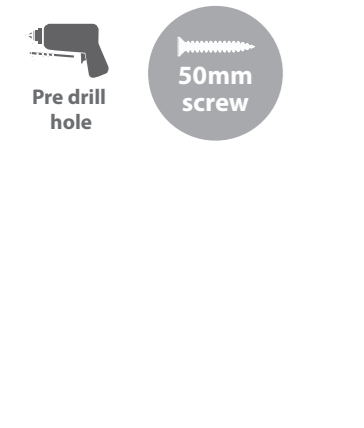

Step 8

Place the gable tops onto the window panels, ensuring the boards interlock.

Secure in place using 4x50mm screws per gable top, screwing in an alternating pattern.

8x50mm Screws

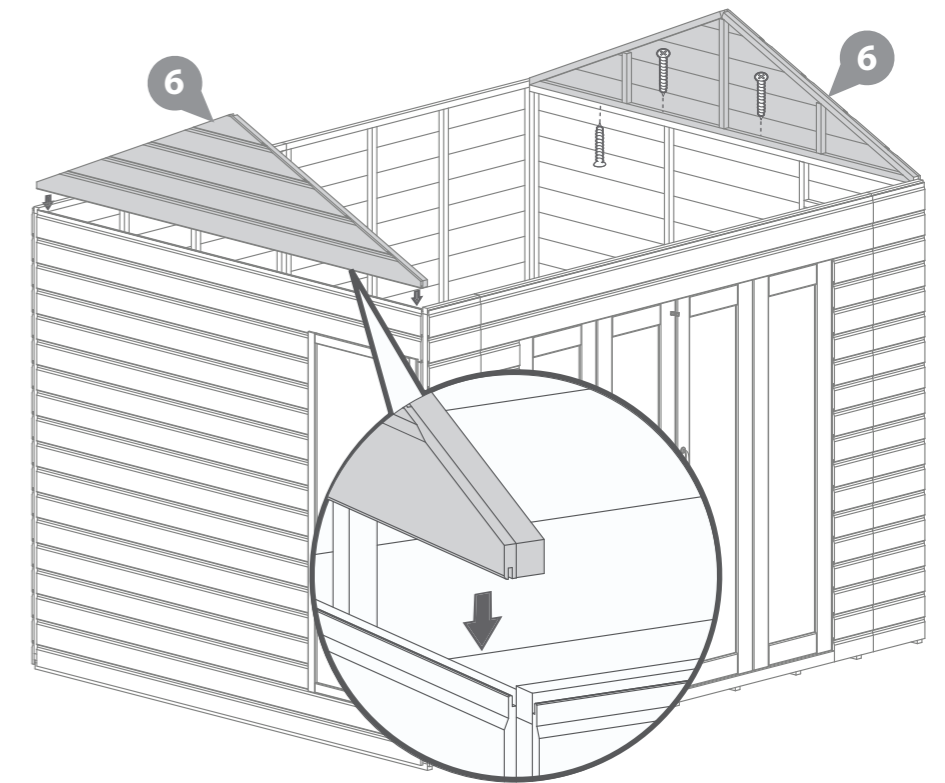
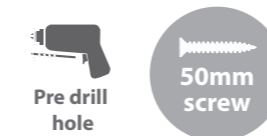

Step 9

Connect the ridge bars together with the metal "U" channel, using 10x30mm screws.

Attach the "L" brackets to each end of the bunk support with 2x30mm screws per bracket.

***Ensure the bracket are flush with the ends of the ridge bar.**

14x30mm Screws

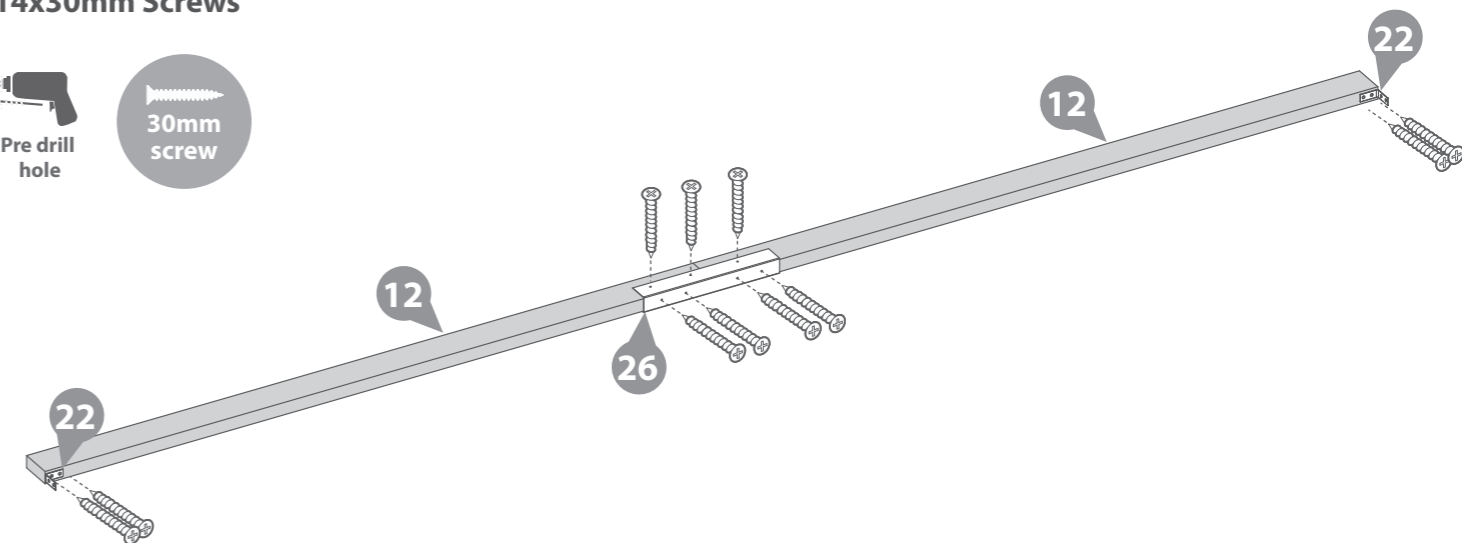

Step 10

Align the ridge bar between the gables and secure to the central uprights with 2x30mm screws per bracket, as shown in the illustration.

**Ensure the ridge bar is flush with the top framing of the gable tops.*

4x30mm Screws

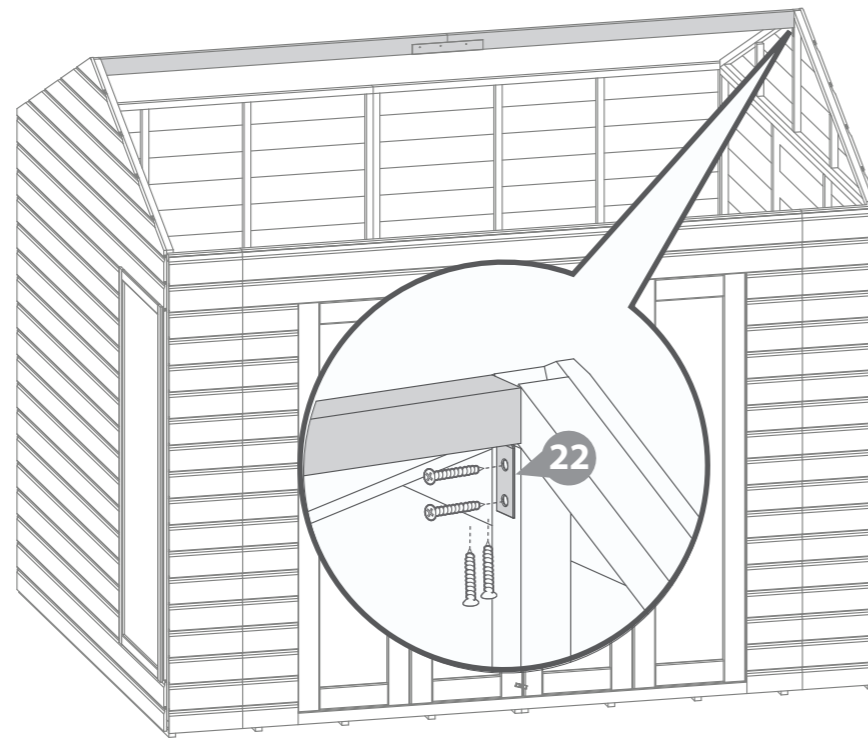

Step 11

Place the roof support bars against the ridge bar and the building, making sure to align the roof support bars with the upright framing on the door panel and the back panel.

Secure the bars into the ridge bar with 1x50mm screw per bar, screwing at an angle as shown in the illustration.

**Ensure to stagger the screws so as not to hit one screw with another.*

2x50mm Screws

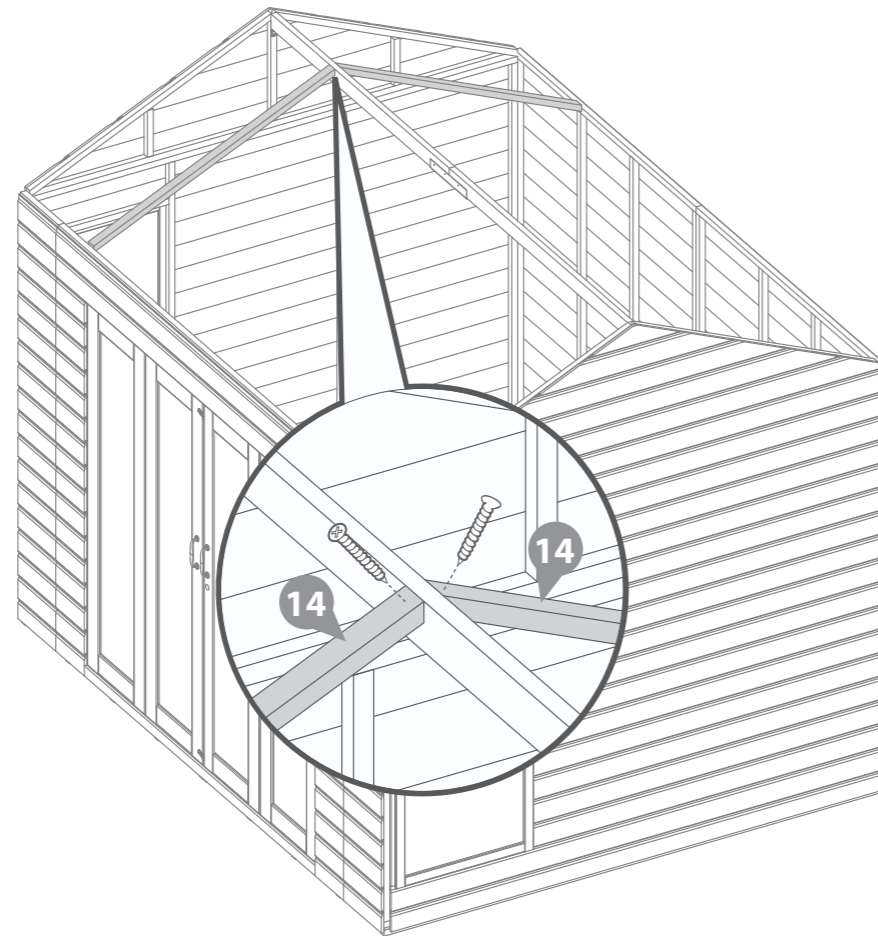

Step 12

Fix the roof support blocks centrally to the back and door panel upright framing with 2x50mm screws per block.

**Ensure the roof support bars meet the blocks and are level with the gables.*

Secure the roof support bar to the block using 1x50mm screw, screwing down through the bar into the block as shown in the illustration.

6x50mm Screws

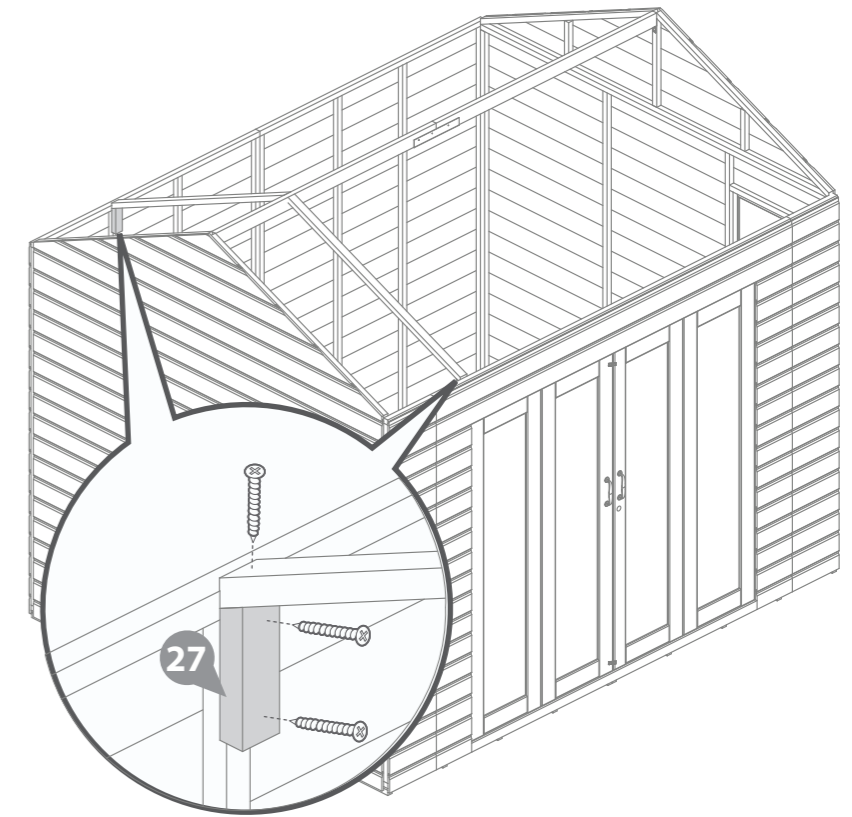
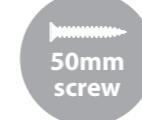

Step 13

Secure the roof support brace between the roof support bars using 2x40mm screws.

2x40mm Screws

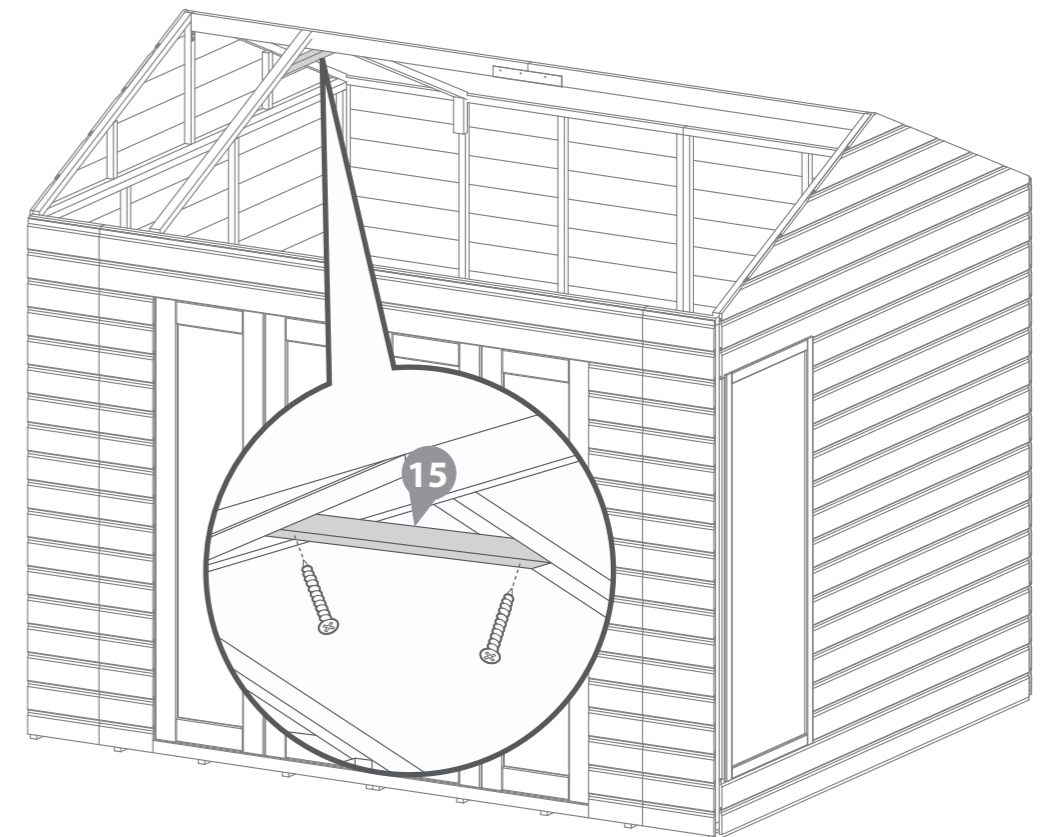

Step 14

Repeat Steps 11, 12 & 13 to finish building the roof support.

4x40mm Screws
16x50mm Screws

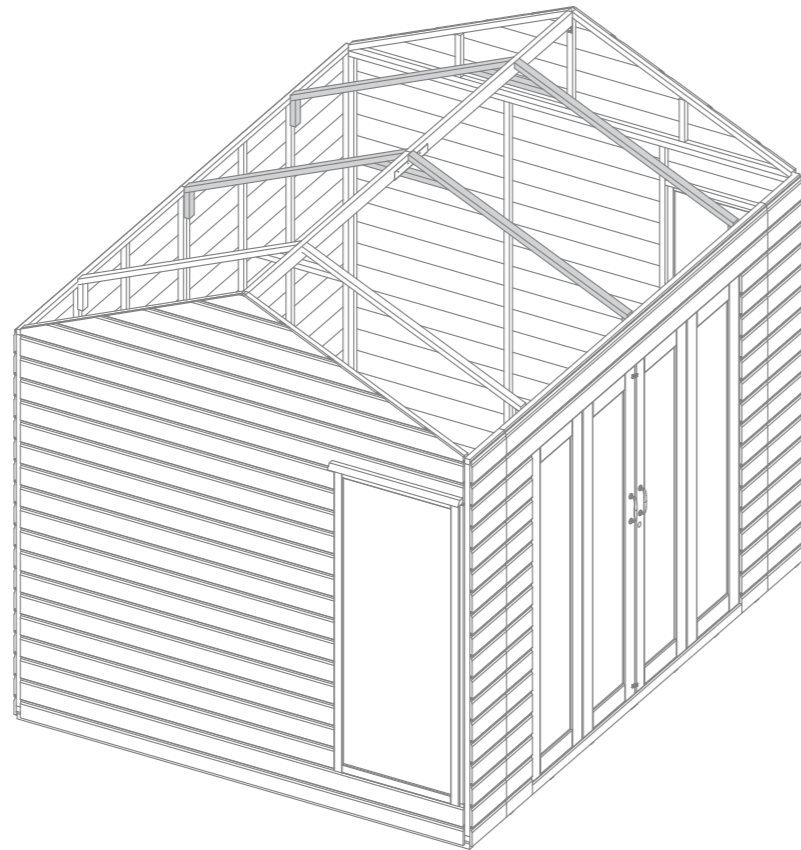

Step 16

- b** Secure the building to the floor using 38x50mm screws.

**Ensure to screw through the framing into the floor bearers.*

38x50mm Screws

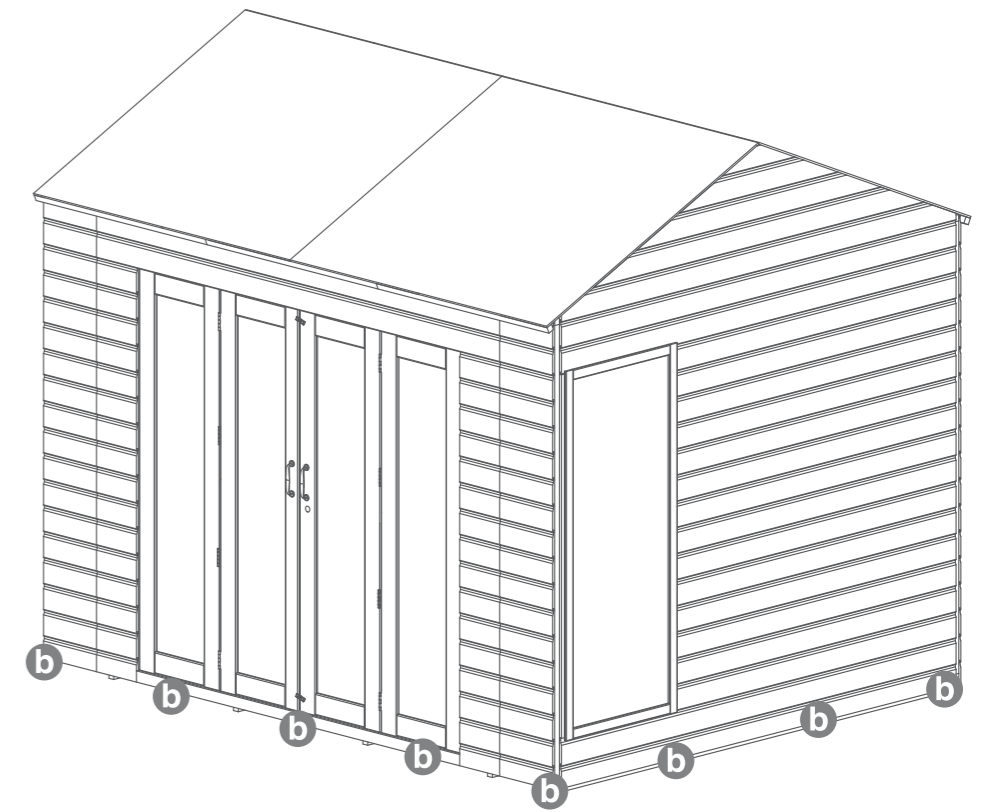

Step 15

Place the first roof sheet on to the building, securing in place with 11x30mm screws.

- a** Fix the first eaves frame onto the roof sheet, securing with 3x30mm screws.

Fix the remaining roof sheets to the building using 11x30mm screws per sheet.

- b** Fix the next eaves frame to the roof with 3x30mm screws.

- c** Secure the remaining eaves frame to the center using 6x30mm screws.

64x30mm Screws

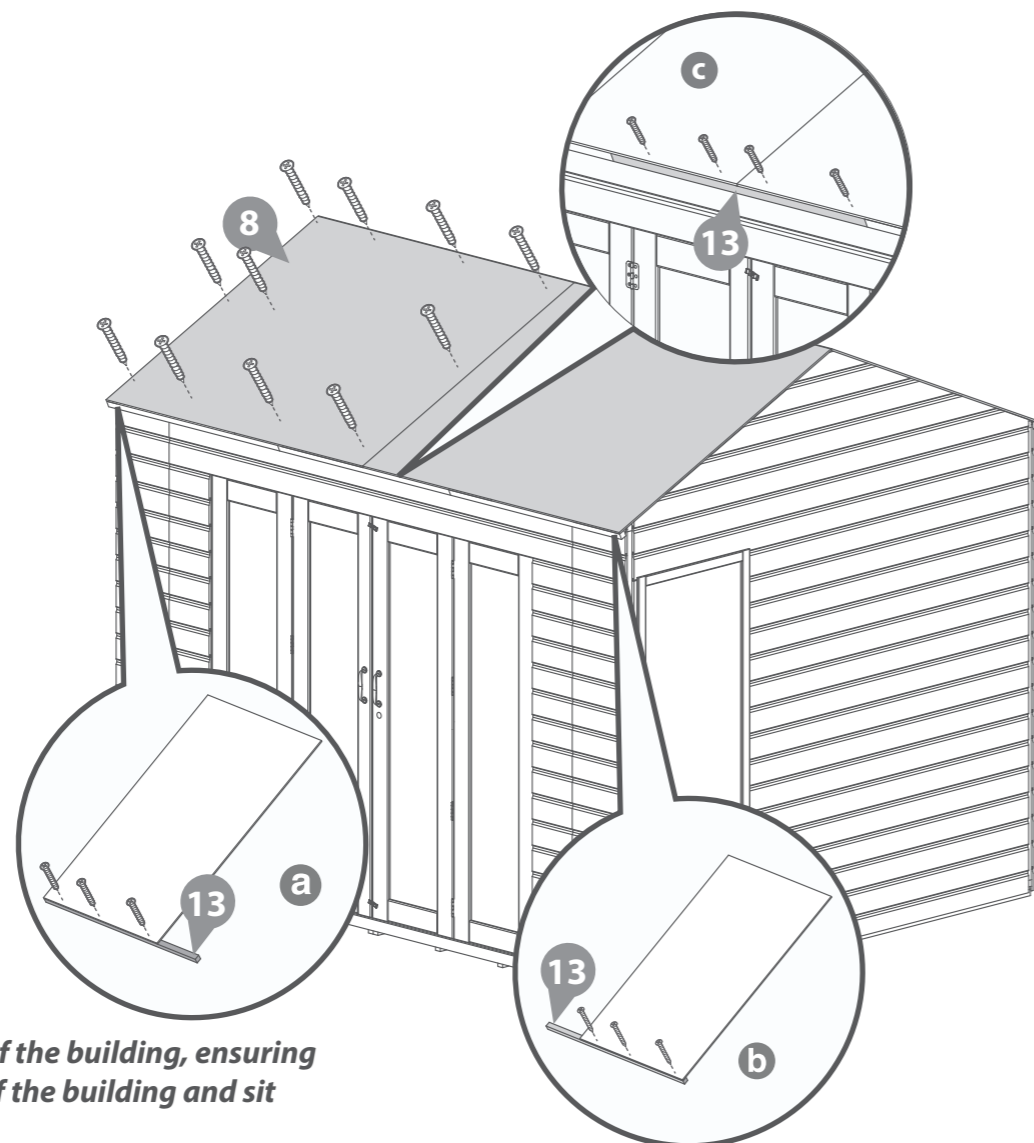

Step 17

Cut the felt into 3 strips of 3100mm length and place onto the roof, as shown in the illustration.

Fix the sheets into place using 132x felt tacks approximately 100mm apart.

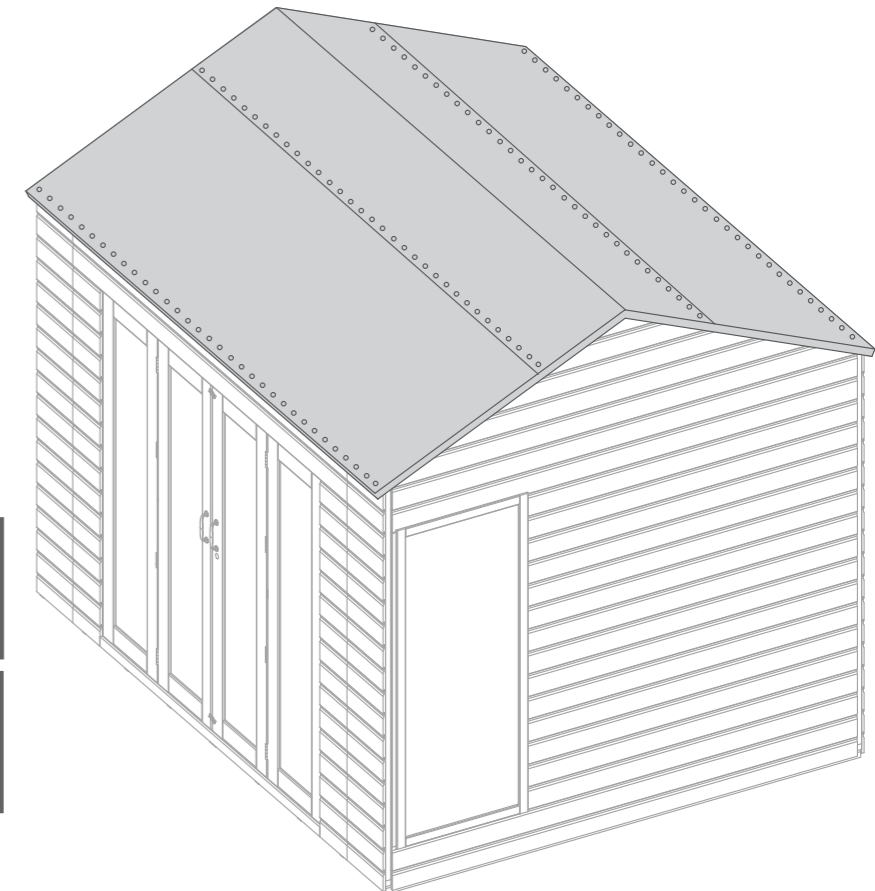
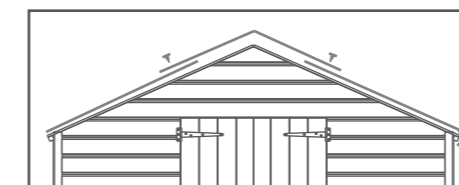
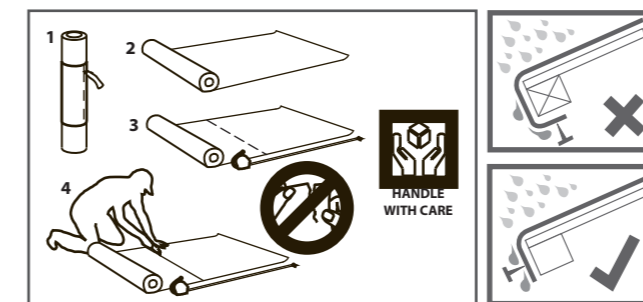

**Repeat this process for both sides of the building, ensuring the roof sheets are flush to the top of the building and sit tight together.*

Step 18

Attach the cover trims to each corner of the building and across each joint between the fixed panels, using 3x30mm screws per cover trim.

21x30mm Screws

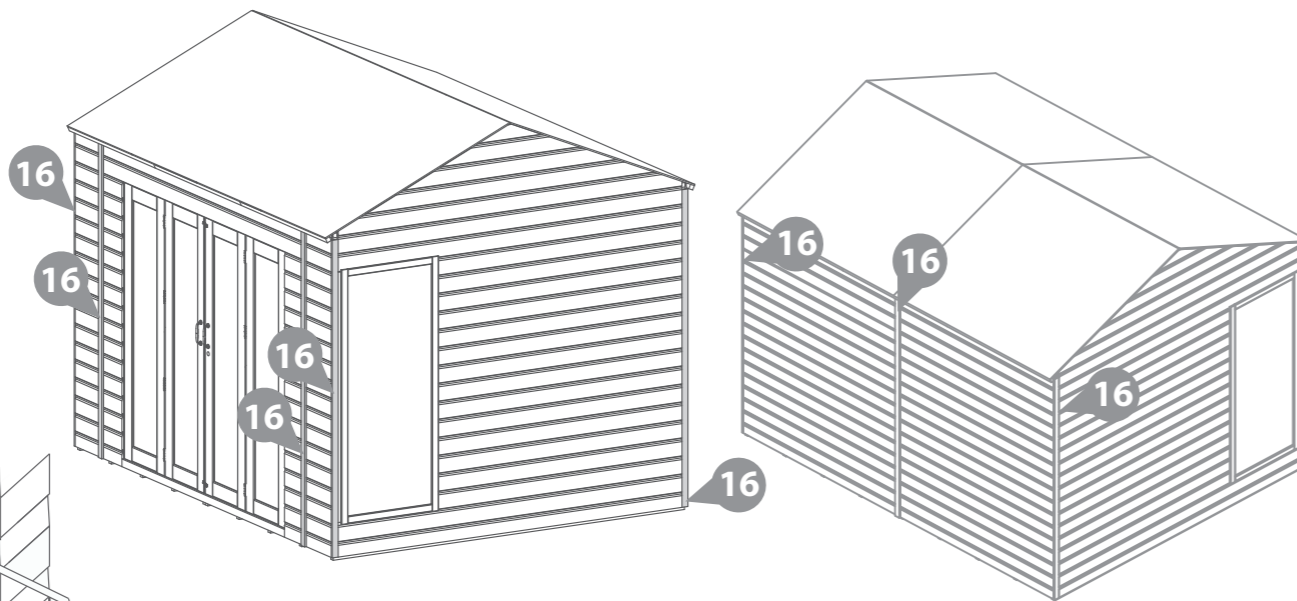
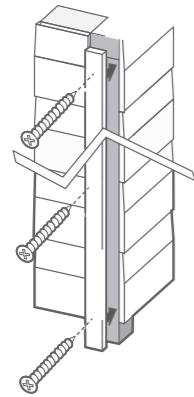

Step 19

Fix the fascias and finials to the front and back of the building using 12x40mm screws.

12x40mm Screws

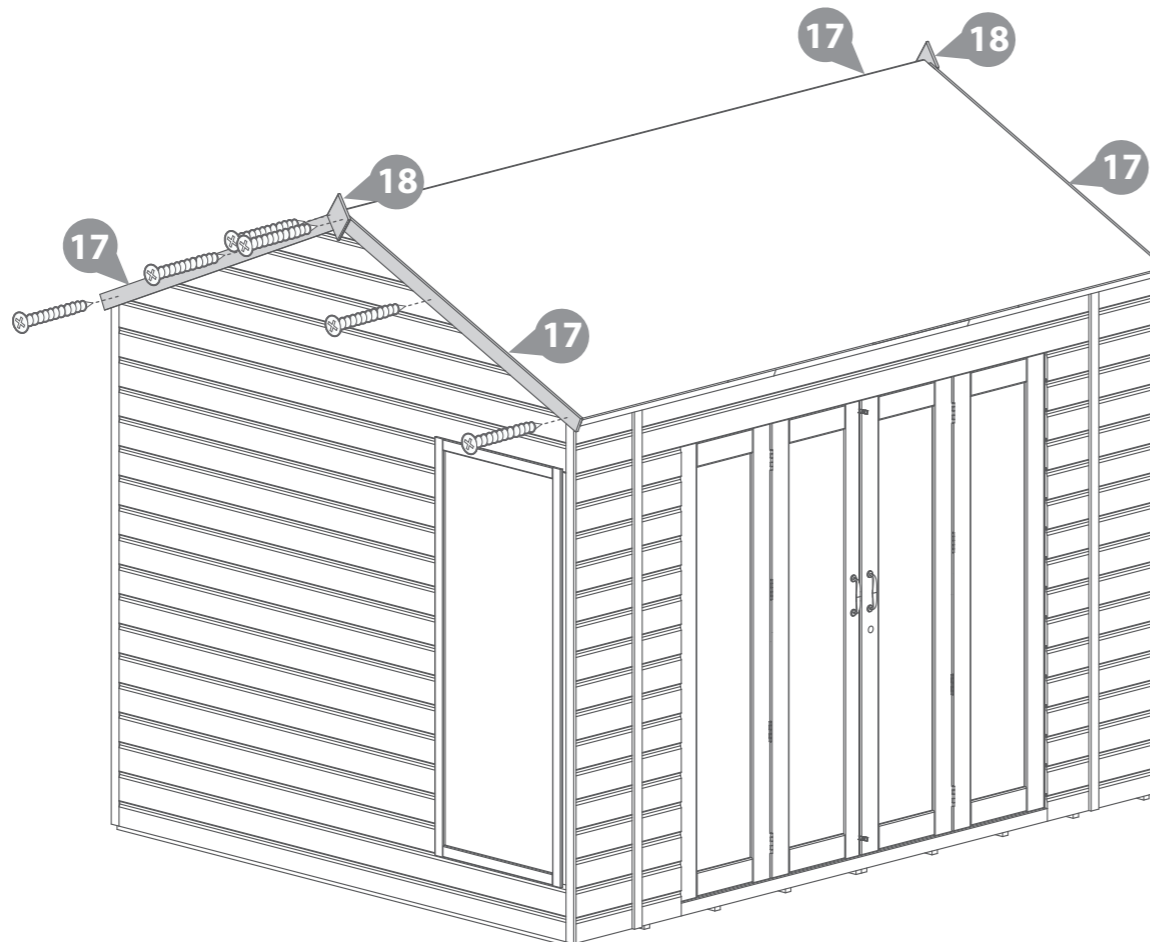

Step 20

Fix the rain guards above each window, securing in place using 2x50mm screws per guard, ensuring to screw through the framing.

4x50mm Screws

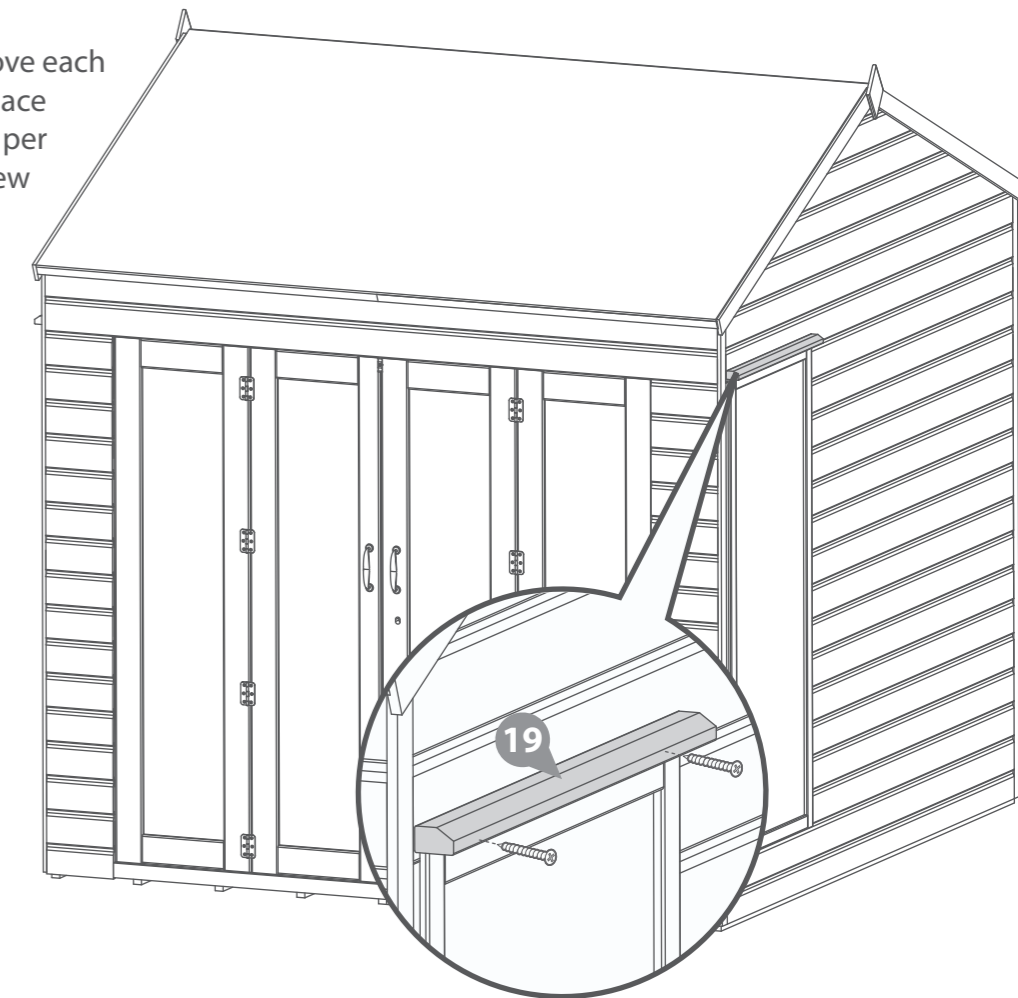

Step 21

Attach the two turn buttons to the slave door at the top and bottom using 2x30mm black screws.

2x30mm Black Screws

**These turn buttons help to keep your doors straight during high & low levels of moisture content in the air.*

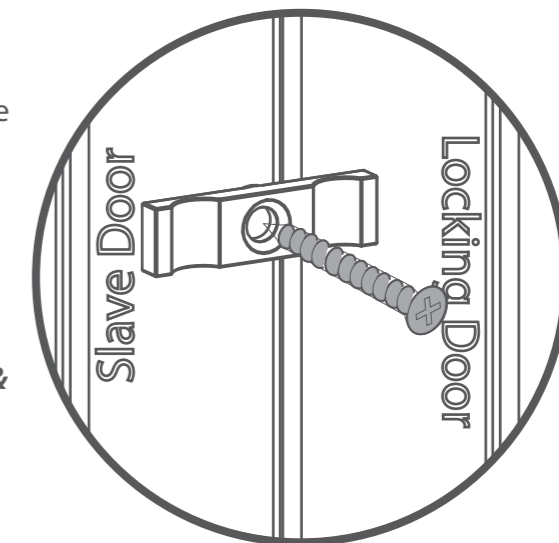

Step 22

Place the Door support Bar(No.29) to the inside of the door panel as displayed in the pictures.

This framing will meet at each side panel as show in image 2.

The 44mm side of the framing should sit against the inside of the door panel, matching the width of the door frame timber.

*Ensure that the framing is attached in a straight line matching the line of the top of the door frame.

*Please be aware this piece of framing may need to be adjusted to length by customer in regards of building tolerances. This piece of framing should fit tightly between the two side panels.

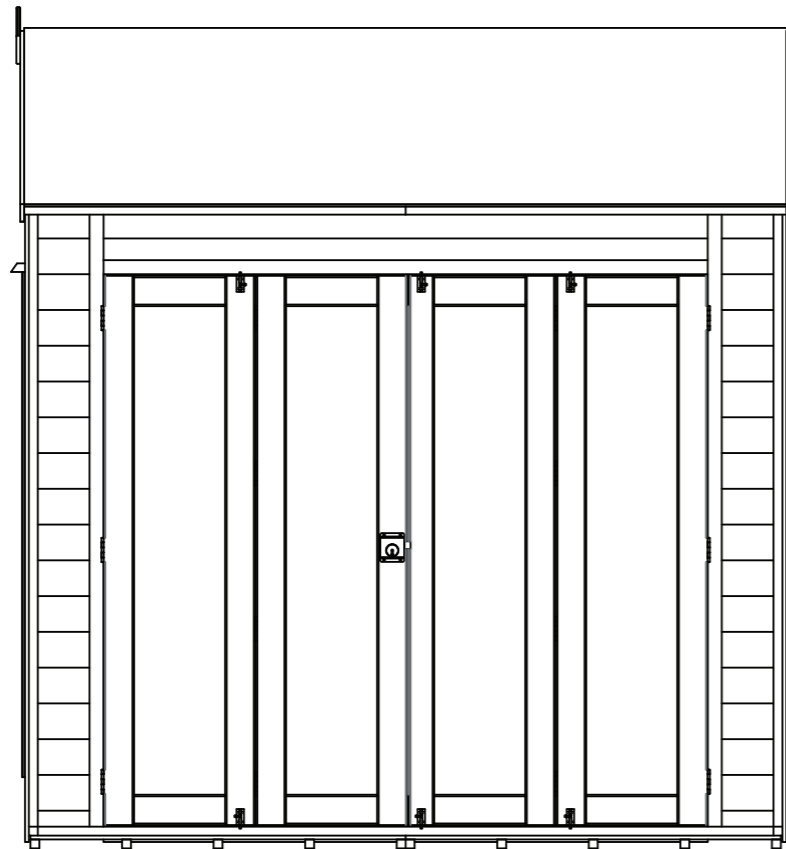

BEFORE

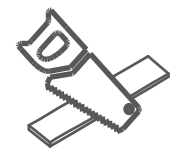

Hand Saw

Step 23

Screw through the side panel externally in line with the 2 x 1 framing using 2 x 70mm screw in either side to secure the framing in place.

Screw through the front panel externally with 4 x 70mm screws equally spaced a part along the door frame to secure the 2 x 1 framing to the panel.

*Please ensure you pre-drill prior to screwing into the panel to eliminate the chances of the timber splitting.

6x70mm screws

A Drill 3 x 6mm holes into the 2 x 1 framing in line with your barrell bolts. These will act as the catch for the barrell bolts at the top of your door.

* Ensure the holes are drilled in to the 2 x 1 framing attached in step 15 as oppose to the door frame.



Pre drill hole



70mm screw

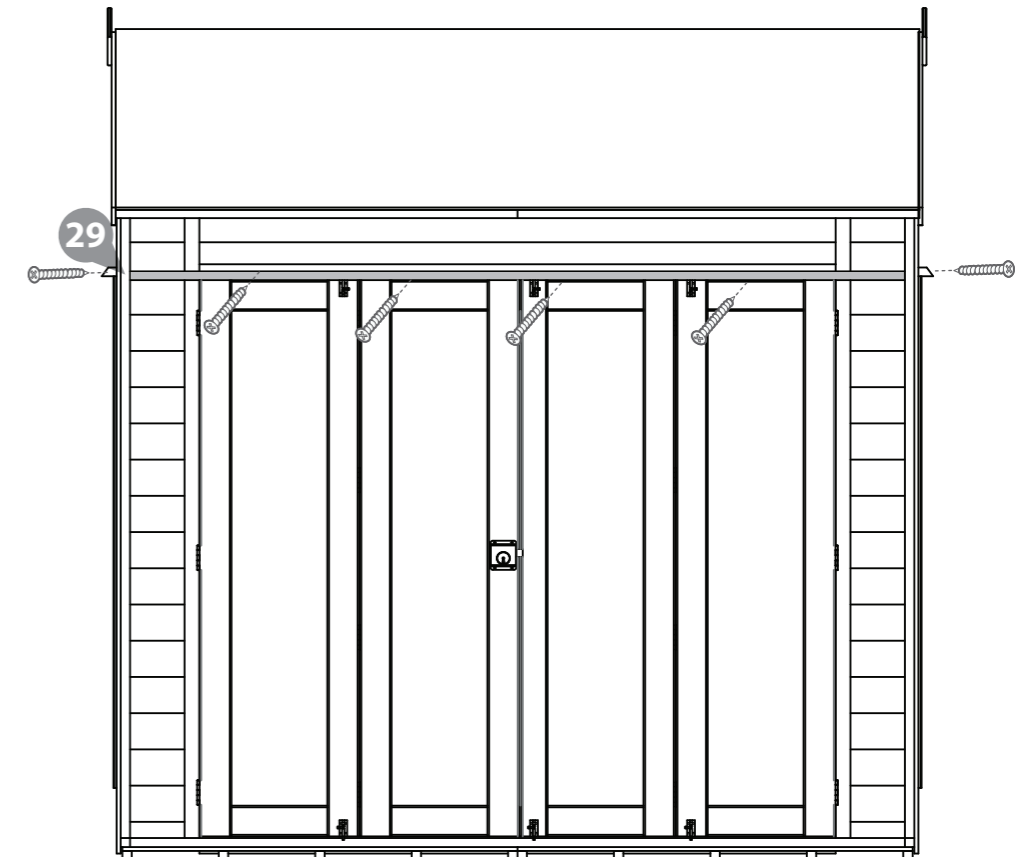

AFTER

Step 24

Attach a strip to the hinged side of the middle opening doors.

***These strips allow you to adjust the doors allowing for moisture absorption and reduction.**

6x30mm Screws



Pre drill hole



30mm screw

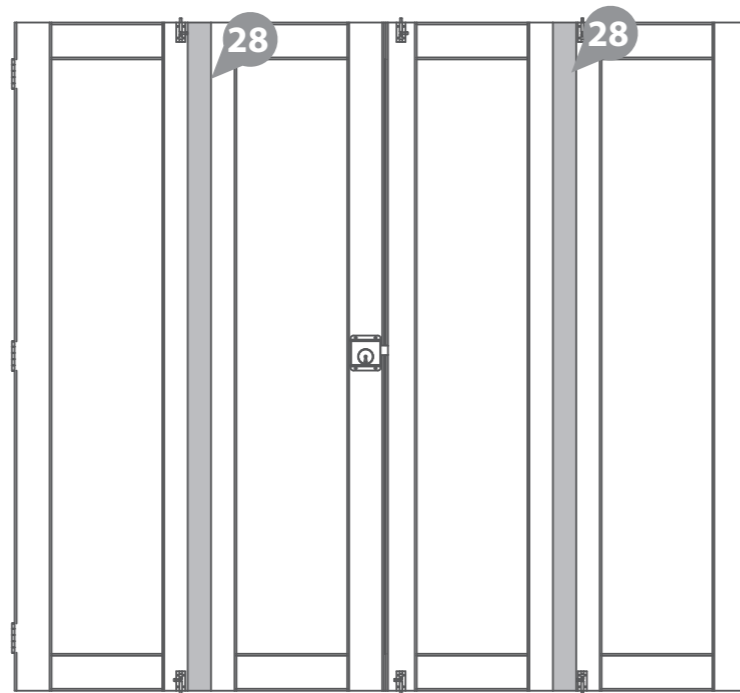

Step 25

it is recommended that after the construction, treatment and the removal of the protective window cover that sealant is used to keep the building weather tight.

