

# Mira Honesty

## EV Bar Valve and Fittings

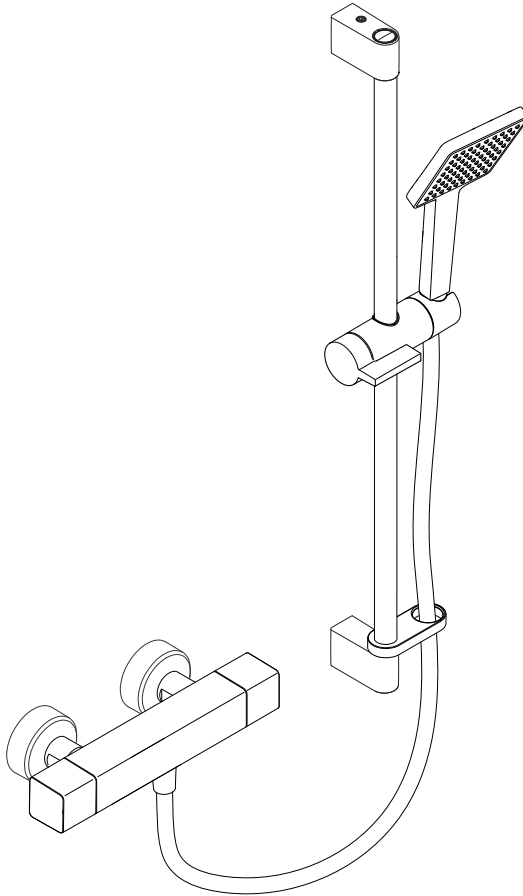

**These instructions must be left with the user**

**Installation and User Guide**

*Showering perfection*

***mira***  
SHOWERS

# Introduction

---

Thank you for choosing a Mira shower. To enjoy the full potential of your new shower, please take time to read this guide thoroughly, and keep it handy for future reference.

## Guarantee

---

For **domestic installations**, Mira Showers guarantee this product against any defect in materials or workmanship for a period of **five** years from the date of purchase (shower fittings for one year).

For **non-domestic installations**, Mira Showers guarantee this product against any defect in materials or workmanship for a period of **one** year from the date of purchase.

**Failure to follow the instructions provided with the shower will invalidate the guarantee.**

For Terms and Conditions refer to the '**Customer Service**'.

## Recommended Usage

---

Domestic	✓
Light Commercial	✓
Heavy Commercial	✗
Healthcare	✗

## Design Registration

---

Design Registration Number	005259041-0006-0007
----------------------------	---------------------

# Pack Contents

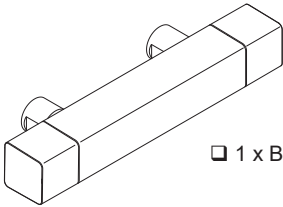

1 x Bar Valve



2 x Wall Brackets



2 x Olives



2 x Compression Nuts

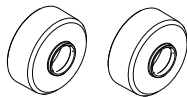

2 x Concealing Plates



2 x Washers/Filters



2 x Wall Plugs



2 x Fixing Screws

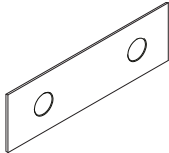

1 x Pipe Guide

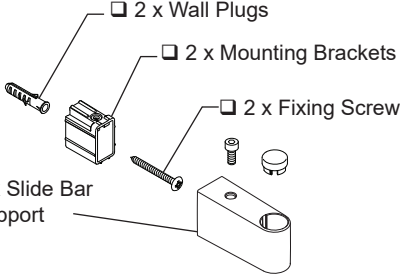

2 x Wall Plugs  
 2 x Mounting Brackets  
 2 x Fixing Screw  
 2 x Slide Bar Support

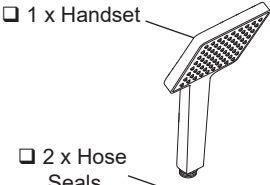

1 x Handset  
 2 x Hose Seals  
 1 x Clamp Bracket

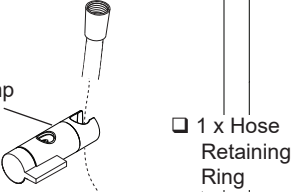

1 x Hose Retaining Ring  
 1 x Hose

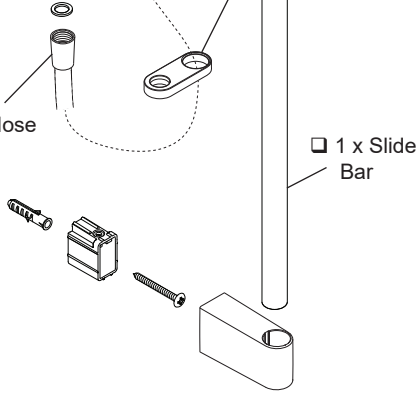

1 x Slide Bar  
 2 x Screws  
 2 x End Cap

# Safety Information

---

**WARNING - This product can deliver scalding temperatures if not operated, installed or maintained in accordance with the instructions, warnings and cautions contained in this guide. The function of a thermostatic mixing valve is to deliver water consistently at a safe temperature. In keeping with every other mechanism, it cannot be considered as functionally infallible and as such, cannot totally replace a supervisor's vigilance where that is necessary. Provided it is installed, commissioned, operated and maintained within manufacturers recommendations, the risk of failure, if not eliminated, is reduced to the minimum achievable. PLEASE OBSERVE THE FOLLOWING TO REDUCE THE RISK OF INJURY:**

## **INSTALLING THE SHOWER**

1. Installation of the shower must be carried out in accordance with these instructions by qualified, competent personnel. Read all instructions before installing the shower.
2. **DO NOT** install the shower where it may be exposed to freezing conditions. Ensure that any pipework that could become frozen is properly insulated.
3. **DO NOT** perform any unspecified modifications, drill or cut holes in the shower or fittings other than instructed by this guide. When servicing only use genuine Kohler Mira replacement parts.
4. If the shower is dismantled during installation or servicing then, upon completion, an inspection must be made to ensure all connections are tight and that there are no leaks.

## **USING THE SHOWER**

1. The shower must be operated and maintained in accordance with the requirements of this guide. Make sure you fully understand how to operate the shower before use, read all instructions and retain this guide for future reference.
2. **DO NOT** switch the shower on if there is a possibility that the water in the shower unit or fittings is frozen.

3. The shower can be used by children aged from 8 years and above and persons with reduced physical, sensory or mental capabilities or lack of experience and knowledge if they have been given supervision or instruction concerning use of the appliance in a safe way and understand the hazards involved. Children must not be allowed to play with the shower.
4. Anyone who may have difficulty understanding or operating the controls of any shower should be attended whilst showering. Particular consideration should be given to the young, the elderly, the infirm or anyone inexperienced in the correct operation of the control.
5. **DO NOT** allow children to clean or perform any user maintenance to the shower unit without supervision.
6. Always check the water temperature is safe before entering the shower.
7. Use caution when altering the water temperature while in use, always check the temperature before continuing to shower.
8. **DO NOT** fit any form of outlet flow control. Only Mira recommended outlet fittings should be used.
9. **DO NOT** operate the temperature control rapidly, allow 10-15 seconds for the temperature to stabilise before use.
10. Use caution when altering the water temperature while in use, always check the temperature before continuing to shower.
11. **DO NOT** switch the shower off and back on while standing in the water flow.
12. **DO NOT** connect the outlet of the shower to any tap, control valve, trigger handset or showerhead other than those specified for use with this shower. Only Kohler Mira recommended accessories must be used.
13. The showerhead must be descaled regularly. Any blockage of the showerhead or hose may affect showering performance.

# Specification

---

## Pressures

- Max Static Pressure: **10 Bar**.
- Max Maintained Pressure: **5 Bar**.
- Min Maintained Pressure: (Gas Water Heater): **1.0 Bar** (for optimum performance supplies should be nominally equal).
- Min Maintained Pressure (Gravity System): **0.1 Bar** (0.1 bar = 1 Metre head from cold tank base to shower handset outlet).

## Temperatures

- Close temperature control is provided between **20°C and 50°C**.
- Optimum Thermostatic Control Range: **35°C to 45°C** (achieved with supplies of 15°C cold, 65°C hot and nominally equal pressures).
- Recommended Hot Supply: **60°C to 65°C** (**Note!** The mixing valve can operate at temperatures up to 85°C for short periods without damage. However for safety reasons it is recommended that the maximum hot water temperature is limited to 65°C).
- Minimum Recommended Differential between Hot Supply and Outlet Temperature: **12°C at desired flow rates**.
- Minimum hot water supply temperature: **55°C**.

## Thermostatic Shut-down

- For safety and comfort the thermostat will shut off the mixing valve **within 2 Seconds** if either supply fails (achieved only if the blend temperature has a minimum differential of 12°C from either supply temperature).

## Connections

- **Hot: Left** - 15mm pipework, 3/4" BSP to valve.
- **Cold: Right** - 15mm to pipework, 3/4" BSP to valve.
- **Outlet: Bottom** - 1/2" BSP Male to flexible hose.

**Note!** This product does not allow for reversed inlets and will deliver unstable temperatures if fitted incorrectly.

# Installation

---

## Suitable Plumbing Systems

### Gravity Fed:

The thermostatic mixer must be fed from a cold water cistern (usually fitted in the loft space) and a hot water cylinder (usually fitted in the airing cupboard) providing nominally equal pressures.

### Gas Heated System:

The thermostatic mixer can be installed with a combination boiler.

### Unvented Mains Pressure System:

The thermostatic mixer can be installed with an unvented, stored hot water system.

### Mains Pressurised Instantaneous Hot Water System:

The thermostatic mixer can be installed with systems of this type with balanced pressures.

### Pumped System:

The thermostatic mixer can be installed with an inlet pump (twin impeller). The pump must be installed on the floor next to the hot water cylinder.

## General

1. Installation of the shower must be carried out in accordance with these instructions by qualified, competent personnel.
2. The plumbing installation must comply with all national or local water regulations and all relevant building regulations, or any particular regulation or practice specified by the local water supply company.
3. Make sure all pressures and temperatures comply with the requirements of the shower. See 'Specifications'.
4. Full bore / non restrictive isolating valves must be fitted in a readily accessible position adjacent to the shower to facilitate maintenance of the shower.  
**DO NOT** use a valve with a loose washer plate (jumper) as this can lead to a build up of static pressure.
5. Use copper pipe for all plumbing.
6. **DO NOT** apply excessive force to plumbing connections; always provide mechanical support when making plumbing connections. Any soldered joints should be made before connecting the shower. Pipework must be rigidly supported and avoid any strain on the connections.
7. Pipework dead-legs should be kept to a minimum.

8. Position the shower unit where the controls are at a convenient height for the user. Position the showerhead so that the water sprays in line with the bath or across the opening of a shower cubicle. The installation must not cause the shower hose to be kinked during normal use or obstruct the use of the control handles.
9. The position of the shower unit and hose retaining ring must provide a minimum air gap of 25 mm between the showerhead and the spill over level of any bath, shower tray or basin. There must be a minimum distance of 30 mm between the showerhead and the spill over level of any toilet, bidet or other appliance with a Fluid Category 5 backflow risk.

**Note!** There will be occasions when the hose retaining ring will not provide a suitable solution for Fluid Category 3 installations, in these instances an outlet double checkvalve must be fitted, this will increase the required supply pressure typically by 10kPa (0.1 bar). Double checkvalves fitted in the inlet supply to the appliance cause a pressure build up, which affect the maximum static inlet pressure for the appliance and must not be fitted. For Fluid category 5 double checkvalves are not suitable.

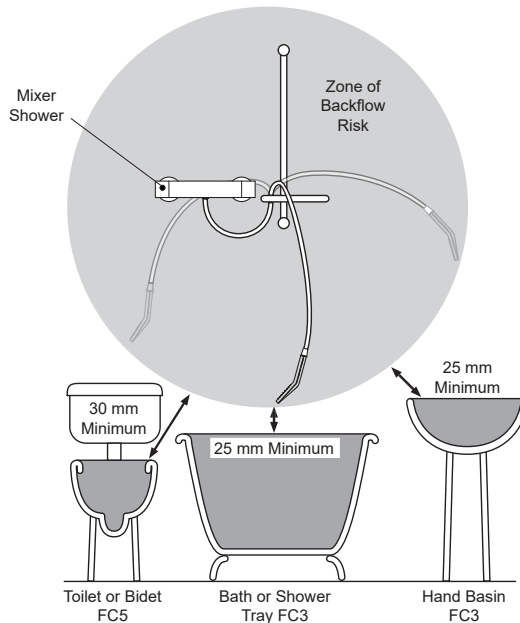

10. Only use the inlet connections supplied with the product. **DO NOT** use any other type of fittings.
11. **DO NOT** overtighten connections, screws or grub screws as product damage may occur.



## Installation of the Bar Valve Fast Fix Kit

1

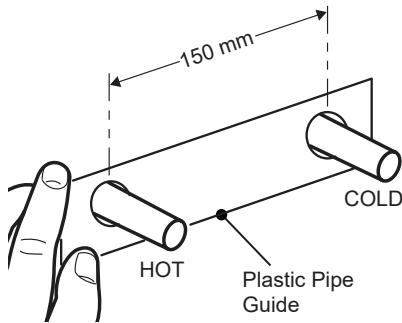

Fit the plastic pipe guide over the inlet pipes. Level the pipe guide and secure to the wall to hold in position. **Leave the guide in place and finish the wall.**

2

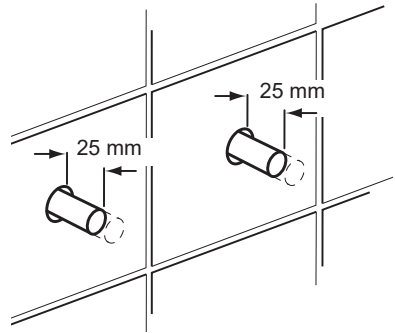

Make sure that the pipework has been installed correctly and that it protrudes 25 mm from the finished wall surface.

3

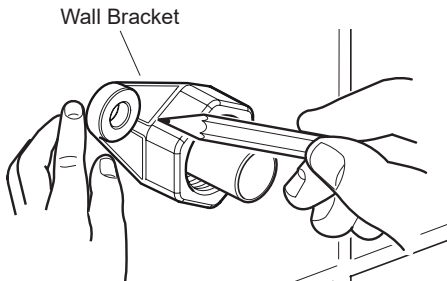

Hold the wall bracket in position and mark the position of the fixing holes.

4

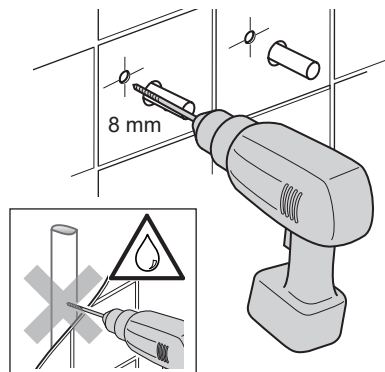

Drill the fixing holes using an 8 mm diameter drill.

5

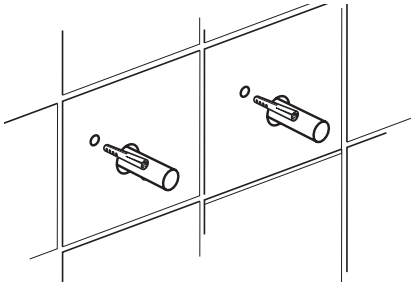

Install the wall plugs.

6

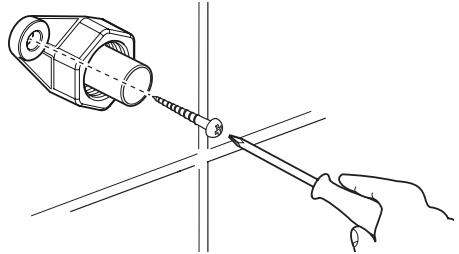

Install the fixing screws and tighten.

7

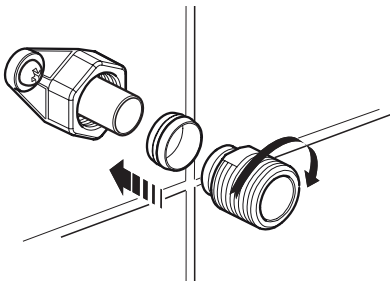

Install the olives and the connectors. Tighten finger tight and then another 1/4 to 1/2 turn.

8

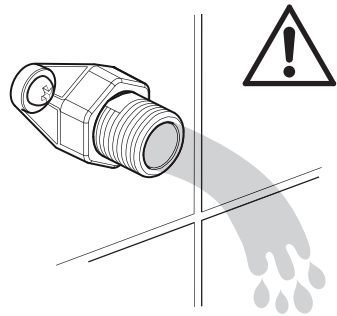

Turn on the water supply and flush the pipework.

9

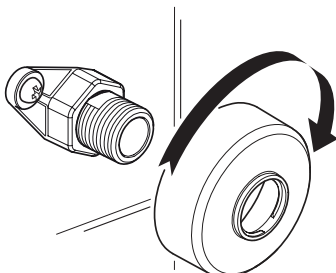

Install the concealing plates.

10

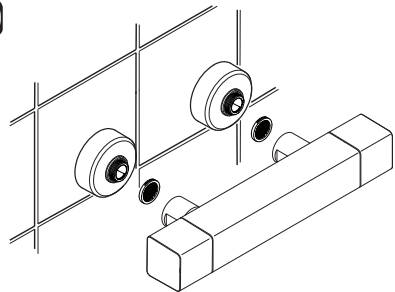

Assemble the bar valve with a sealing washer / filter in each inlet and attach to the wall bracket.

**Note! Connections are: Hot-Left, Cold- Right.**

## Installing the Shower Fittings

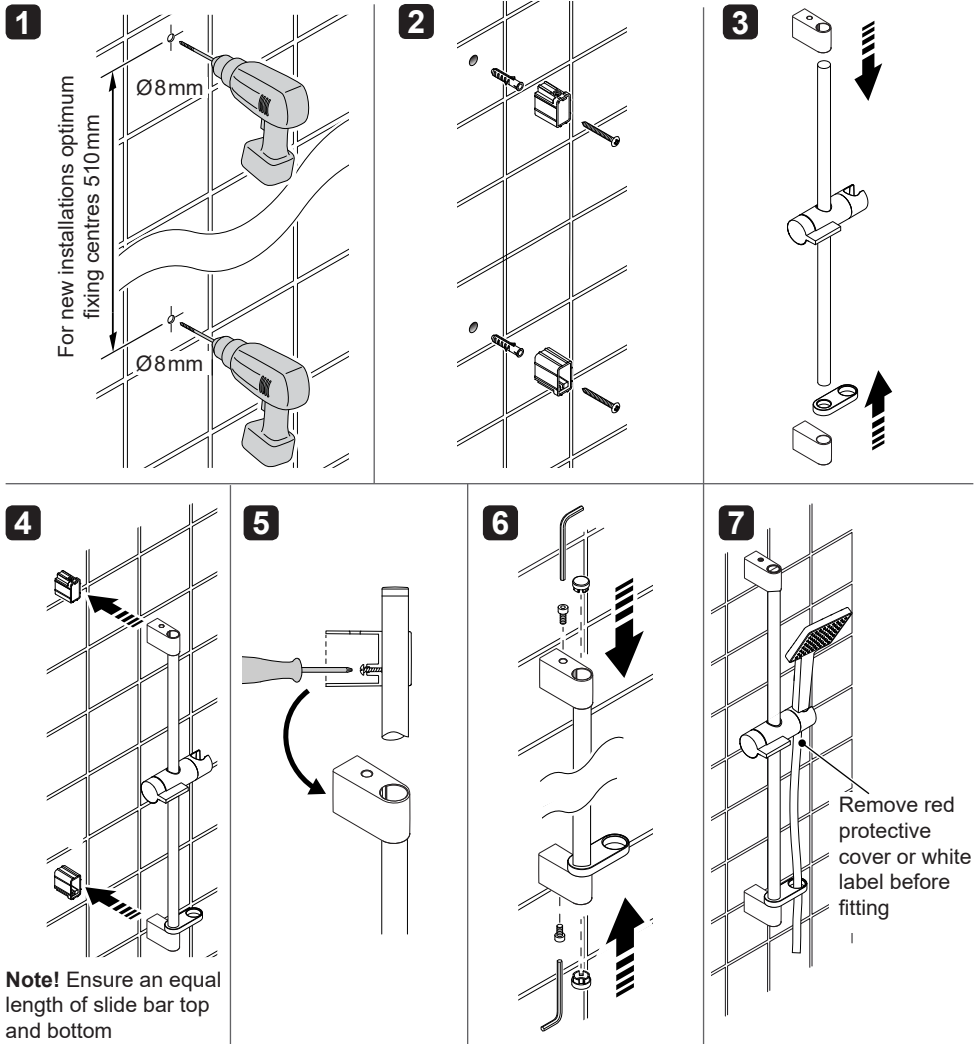

- 8** A flow regulator (not supplied) may be required for installation on high pressure systems (above 0.5bar).

## Connecting the Shower Hose

- 9** Connect the conical with the red cover or the white label to the showerhead.

# Commissioning

## Maximum Temperature Setting

Follow this procedure to check and adjust the temperature before using the shower for the first time. **Make sure that all users are familiar with the operation of the shower. This guide is the property of the homeowner and must be left with them following installation completion.**

The shower's maximum temperature has been pre set to 46 C, but may require adjustment for the following reasons:

- To reset to a comfortable temperature (may be required to suit the plumbing system).
- To suit your showering preference.

**The following procedure requires a constant supply of hot water at a minimum temperature of 55°C.**

1. Turn the shower **ON** to full flow.
2. Turn to full hot. Allow the temperature and flow to stabilise.
3. To set the temperature to either warmer or cooler, pull off the temperature knob taking care not to rotate the hub. **Note!** Take care not to damage the chrome if a tool is used to lever off.
4. To increase the temperature, rotate the hub in an anticlockwise direction, colder turn clockwise. Make small adjustments and allow temperature to settle before making further adjustments. Continue to adjust until the required temperature is achieved.
5. Remove the fixing screw securing the hub and refit aligning the hub as shown. Clips to be orientated in the 3, 6, 9 and 12 O'clock positions.
6. Retighten the fixing screw without rotating the hub.
7. Push on the temperature knob making sure that it locates correctly. **Note!** The arrow on the inside of the handle should point downwards.
8. Rotate the temperature knob to full cold then rotate back to full hot and check the maximum temperature is set correctly.

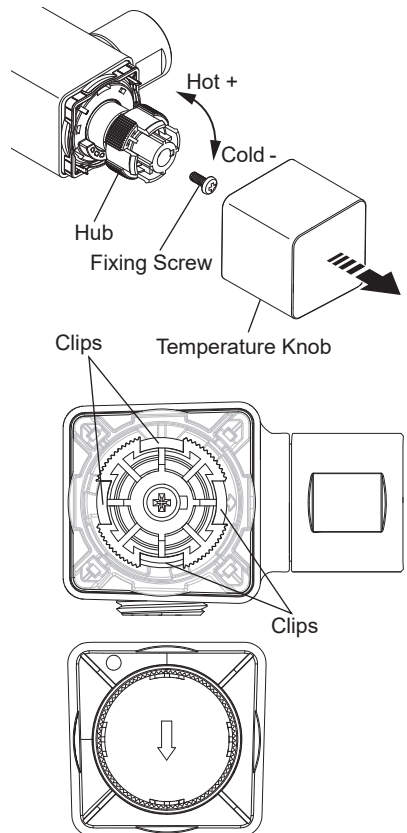

**Inside View of  
Temperature Knob**

# Operation

---

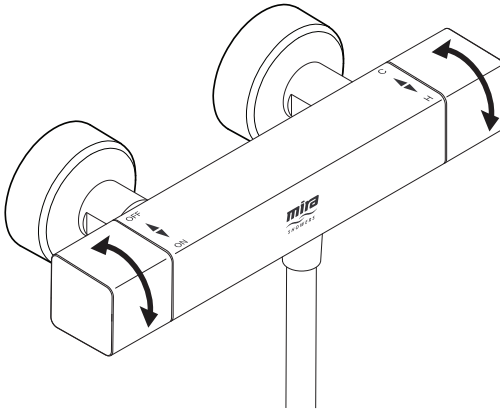

## Flow Operation

Use the flow handle to turn the shower on / off.

## Adjusting the Temperature

Use the temperature handle to make the shower warmer or cooler.

# User Maintenance

---

## **WARNING! PLEASE OBSERVE THE FOLLOWING TO REDUCE THE RISK OF INJURY OR PRODUCT DAMAGE:**

1. **DO NOT** allow children to clean or perform any user maintenance to the shower unit without supervision.
2. If the shower is not to be used for a long period, the water supply to the shower unit should be isolated. If the shower unit or pipework is at risk of freezing during this period, a qualified, competent person should drain them of water.

## Cleaning

Many household and commercial cleaners, including hand and surface cleaning wipes contain abrasives and chemical substances that can damage plastics, plating and printing and should not be used.

**Important! The showerhead must be descaled regularly,** keeping the showerhead clean and free from limescale will ensure that your shower continues to give the best performance. Limescale build up can restrict the flow rate and may cause damage to your shower.

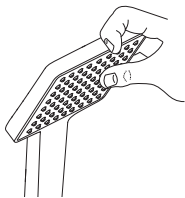

Use your thumb or a soft cloth to wipe any limescale from the nozzles.

## Inspecting the Hose

**Important!** The shower hose should be inspected periodically for damage or internal collapse, internal collapse can restrict the flow rate from the showerhead and may cause damage to the shower.

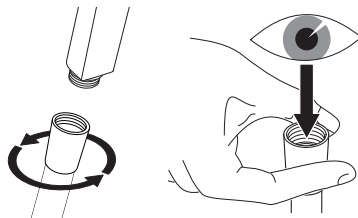

1. Unscrew the hose from the showerhead and the shower outlet.
2. Inspect the hose.
3. Replace if necessary.

# Fault Diagnosis

If you require a Mira trained service engineer or agent, refer to **'Customer Service'**.

Symptom	Cause/Rectification
Water too hot or too cold	Inlets reversed (hot supply to cold inlet of shower unit), rework inlet pipework. Check the washer/filters are not blocked. Check the maximum temperature setting (If you have a combination type boiler it may not be producing sufficient hot water at the desired flow rate). Fit a flow regulator to the outlet of the shower unit. Installation conditions outside operating parameters, refer to <b>'Specifications'</b> and <b>'Commissioning'</b> .
Poor temperature control	Make sure that the inlet temperature differentials are sufficient, refer to <b>'Specifications'</b> .
Fluctuating or reduced flow	Check the showerhead and hose are not blocked. Check the washer/filters are not blocked. Make sure that the maintained inlet pressures are nominally balanced and sufficient, refer to <b>'Specifications'</b> . Air lock or partial blockage in the pipework.
Water leaking from the showerhead	Water may drain from the showerhead for a short period after showering, this is normal.

# Spare Parts

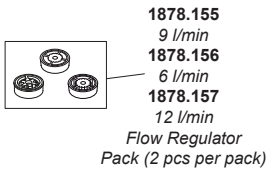
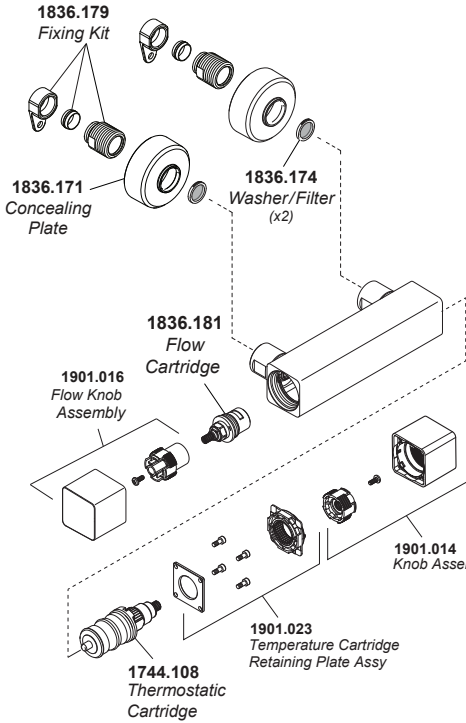

**Note!** These flow regulators are fitted in the shower fittings

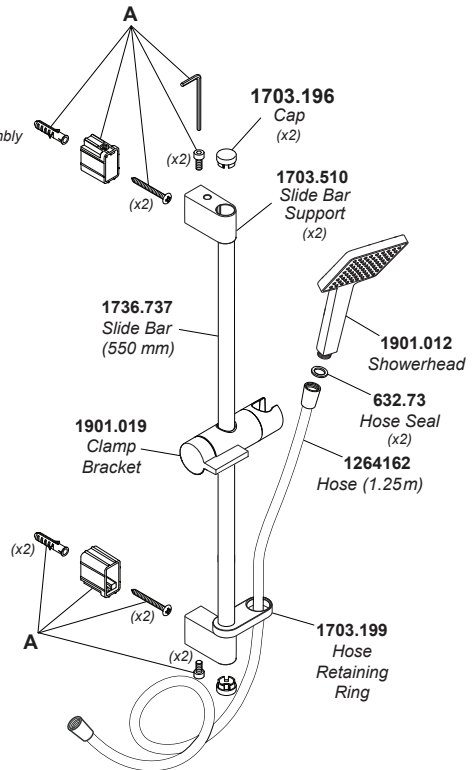

1736.740 Seal Pack - 'A'

# Customer Service

## Guarantee

Your product has the benefit of our manufacture's guarantee which starts from date of purchase. This guarantee only applies in the United Kingdom and Republic of Ireland. To activate this guarantee, please return your completed registration card, visit our website or free phone 0800 5978551 within 30 days of purchase (UK only).

Within the guarantee period we will resolve defects in materials or workmanship, free of charge, by repairing or replacing parts or product as we may choose.

**This guarantee is in addition to your statutory rights and is subject to the following conditions :**

- The guarantee applies solely to the original installation under normal use and to the original purchaser only. The product must be installed and maintained in accordance with the instructions given in this guide.
- Servicing must only be undertaken by us or our appointed representative.

**Note!** If a service visit is required the product must be fully installed and connected to services.

- Repair under this guarantee does not extend the original expiry date. The guarantee on any replacement parts or product ends at the original expiry date.
- For shower fittings or consumable items we reserve the right to supply replacement parts only.

**The guarantee does not cover:**

- Call out charges for non product faults (such as damage or performance issues arising from incorrect installation, improper use, inappropriate cleaning, lack of maintenance, build up of limescale, frost damage, chemical attack, corrosion, system debris or blocked filters) or where no fault has been found with the product.
- Water or electrical supply, waste and isolation issues.
- Compensation for loss of use of the product or consequential or indirect loss of any kind.
- Damage or defects caused if the product is repaired or modified by persons not authorised by us or our appointed representative.
- Routine maintenance or replacement parts to repaired or modified by persons not authorised by comply with the requirements of the TMV2 or repaired or modified by persons not authorised by TMV3 healthcare schemes
- Accidental or wilful damage.
- Products purchased ex-showroom display.

## What to do if something goes wrong

If your product does not work correctly refer to this manual for fault diagnosis and check that it is installed and commissioned in accordance with our instructions. If this does not resolve the issue, contact us for help and advice.



### Helpdesk Service

Contact our Customer Services Team for product advice, to purchase spare parts or accessories or to set up service visit. You can contact us via phone or e-mail - contact details below.

Please provide your model name, power rating (if applicable) and date of purchase.



### Mira Showers Website

([www.mirashowers.co.uk](http://www.mirashowers.co.uk))

Visit our website to register your guarantee, download user guides, diagnose faults, purchase our full range of accessories and popular spares, or request a service visit.



### Spares and Accessories

We hold the largest stocks of genuine Mira spares and accessories. Contact us for a price or visit our website to purchase items from our accessory range and popular spares. (Only available in the United Kingdom )



### Service/Repairs

No one knows our products better than our nationwide team of Service Technicians. We can carry out service or repair work to your product both during and after the guarantee period. (Only available in the United Kingdom and Republic of Ireland) Ask about our fixed price service repairs.

**To Contact Us: UK**



**0800 001 4040**



**Fax: 01242 282595**



Email – Visit

[www.mirashowers.co.uk/contactus](http://www.mirashowers.co.uk/contactus)



By Post: **Mira Customer Services Dept, Cromwell Road, Cheltenham, Gloucestershire GL52 5EP**

**To Contact Us: Eire Only**



**01 531 9337**



E-mail:

[CustomerServiceEire@mirashowers.com](mailto:CustomerServiceEire@mirashowers.com)

*Mira is a registered trade mark of  
Kohler Mira Limited.*

*The company reserves the right to alter  
product specifications without notice.*



**mira**  
SHOWERS