



Fitting type: Undermount or Inset

Sink handing: Right hand main bowl

Finish style: Brushed steel

- **Min. base unit (mm):** 800
- **Packaged size L x W x D:** 640 x 500 x 280mm
- **Supplied boxed or sleeved:** Boxed
- **Boxed weight:** 7.90 kg
- **Sink only weight:** 4.58 kg

- Durable 304 stainless steel construction throughout
- Deep bowl(s) to accept larger cookware
- Easy clean bowl curves
- Smooth lined luxury Orbit waste supplied as standard
- Can be fitted as undermount or inset

Included parts:



2 x AX1001 (m)
90mm (1.5") Orbit manual basket
strainer waste - short bolt



2 x AX1105 (m)
Rectangular overflow (55x30mm
vertical)



1 x AX1009 (m)
1.5 or 2.0 Bowl pipework



1 x AX1109 (m)
Inset stainless steel fixing clips x 12



1 x AX1108 (m)
Undermount stainless steel fixing clips
x 8



1 x AX4029 (m)
Fitting & care instructions & data
sheet - st/st inset or undermount

Recommended accessories:



1 x AX3012
Bowl mat 273 x 333 R5



1 x AX2503
High & Dry drainer rack - White and
grey

All accessories can be purchased directly from www.abode-shop.co.uk or phone 01226 283434

Materials and workmanship warranty summary:

- Sink materials & workmanship 10 years.
- Waste kits 1 year.
- Connecting pipework 1 year.

Care instructions:

- Clean the products regularly using soapy water and a non abrasive cloth, regular cleaning will prevent the build up of lime scale and dirt.
- Avoid contact with corrosive or abrasive substances.
- After cleaning rinse thoroughly with clean water then dry.
- For more detail see supplied booklet or www.abodedesigns.co.uk

Product dimensions and installation information: note:



symbol indicates position of acoustic pad on stainless products.

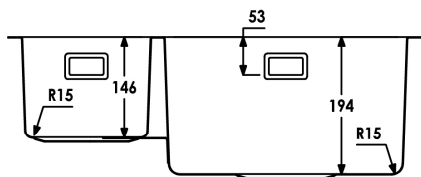
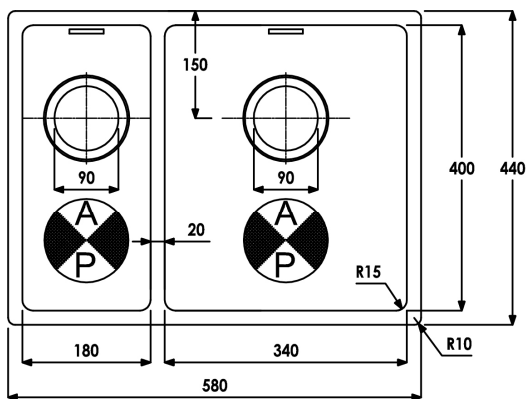

INSET CUT OUT

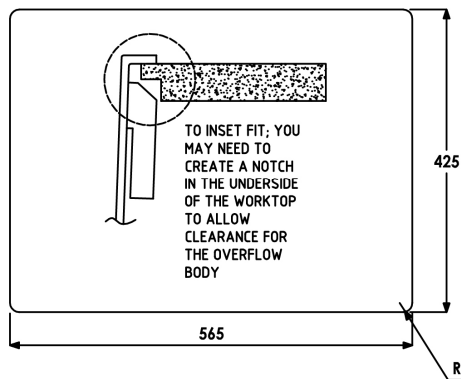

UNDERMOUNT CUT OUT

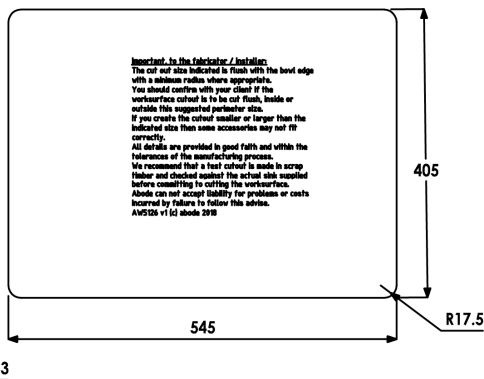

Additional notes: Important: Please check cut out details carefully before cutting worktops, size shown is flush to bowl edge
Overall product size: 580 x 440 x 202 corner radius 10mm

Tap hole(s) detail: None

Compatibility with large square taps:

Wastehole(s) detail (mm): 90 / 90 / N/A (nb. 90mm wastes accept a waste disposal unit)

Min. base unit (refers to space required for bowl, tap and overflow only): fits 800mm carcass

Min. Recessed fitting width: required (bowl(s), tap and overflow): 535 mm

***Worktop cut out size:** varies x varies corner radius varies mm, for .DXF cut files please see www.abode.eu

Min. & Max worktop depth or clip depth reach range: 0 - 55mm

Fitting temple supplied? No, use cut out instructions as supplied

Dishwasher under drainer? Distance from top of worktop to underside of the drainer n/amm



***Important, fabricator / installer notes for undermount & flushmount sinks:**

The cut out size indicated is aligned with outside edge of the bowl top radius (see example below).

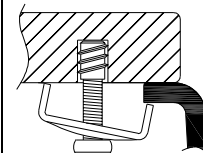

You should confirm with your client if the worksurface cutout is to be cut flush, inside or outside this suggested perimeter shape & size.

If you create the cutout smaller or larger than the indicated size then the fit of the accessories may be affected and should be physically checked.

General:

All details are provided in good faith but do not include the tolerances of the material or manufacturing process.

We request that a test cutout is made in scrap timber and checked against the actual sink to be installed before committing to cutting the final worksurface.

Abode can not accept liability for problems or costs incurred by failure to follow this request.

Note: the dimensions on ceramic fireclay products are subject to wider tolerances due to the nature of this natural material and the firing process.

CAD cutout files can be downloaded from www.abodedesigns.co.uk

Bowl details: (sizes in mm unless specified otherwise)

Bowl 1 (typically main bowl):

Bowl 1 size L x W x D (mm): 340 x 400 x 194

Bowl 1 construction: Pressed, 1.00mm

Bowl 1 floor radius (mm): 15

Bowl 1 Wastehole diameter (mm): 90

Bowl 1 overflow: Rectangular flush

Bowl 1 texture: Brushed stainless

Bowl 1 apx. volume (litres): 18.50

Bowl 2 (typically 1/2 or 3/4 bowl):

Bowl 2 size L x W x D (mm): 180 x 400 x 146

Bowl 2 construction: Pressed, 1.00mm

Bowl 2 floor radius (mm): 15

Bowl 2 Wastehole diameter (mm): 90

Bowl 2 overflow: Rectangular

Bowl 2 texture: Brushed stainless

Bowl 2 apx. volume (litres): 7.70

Bowl 3:

Bowl 3 size L x W x D (mm): N/A x N/A x N/A

Bowl 3 construction: N/A, N/Amm

Bowl 3 floor radius (mm): N/A

Bowl 3 Wastehole diameter (mm): N/A

Bowl 3 overflow: N/A

Bowl 3 texture: N/A

Bowl 3 apx. volume (litres): N/A