

AQUALISA ISYSTEM™ EXPOSED

ISD.A2.EV.14

WITH ADJUSTABLE HEAD - GRAVITY PUMPED

DIMENSIONAL DRAWINGS

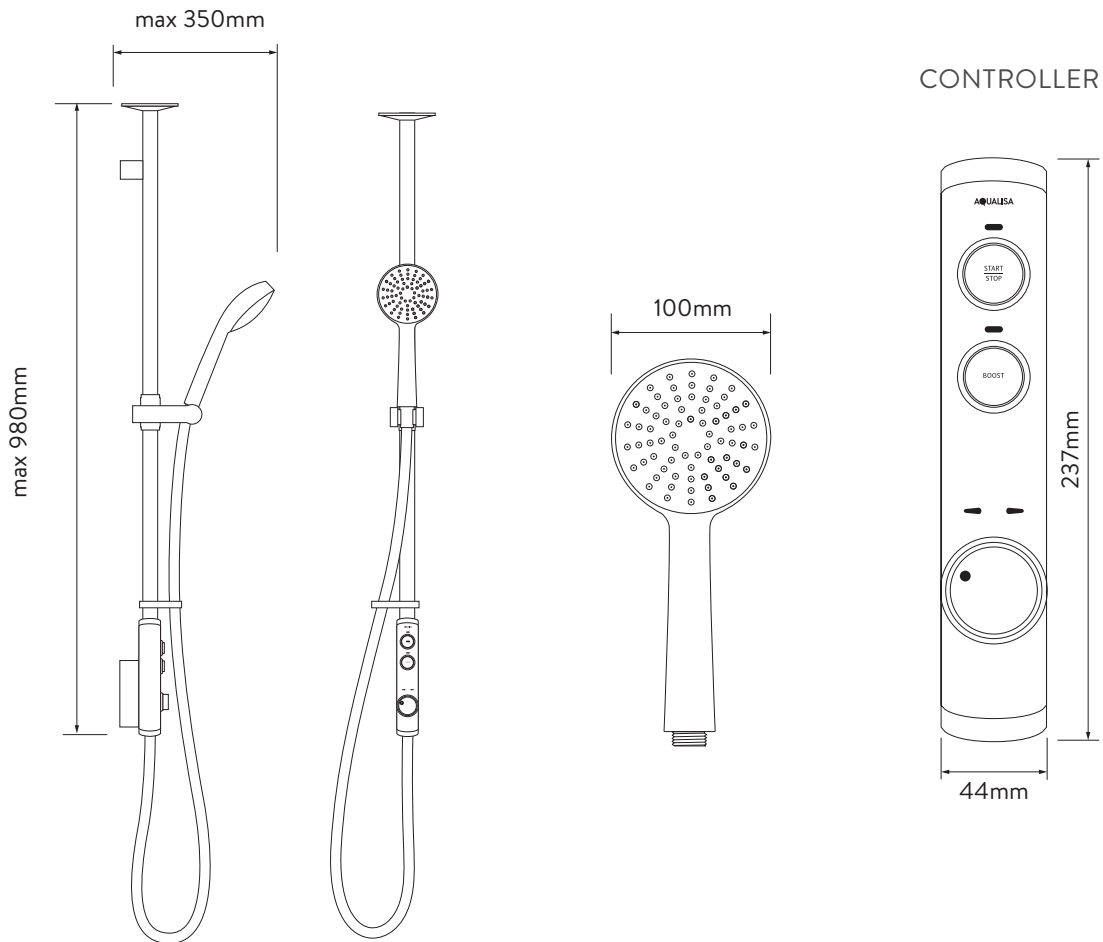

PROCESSOR

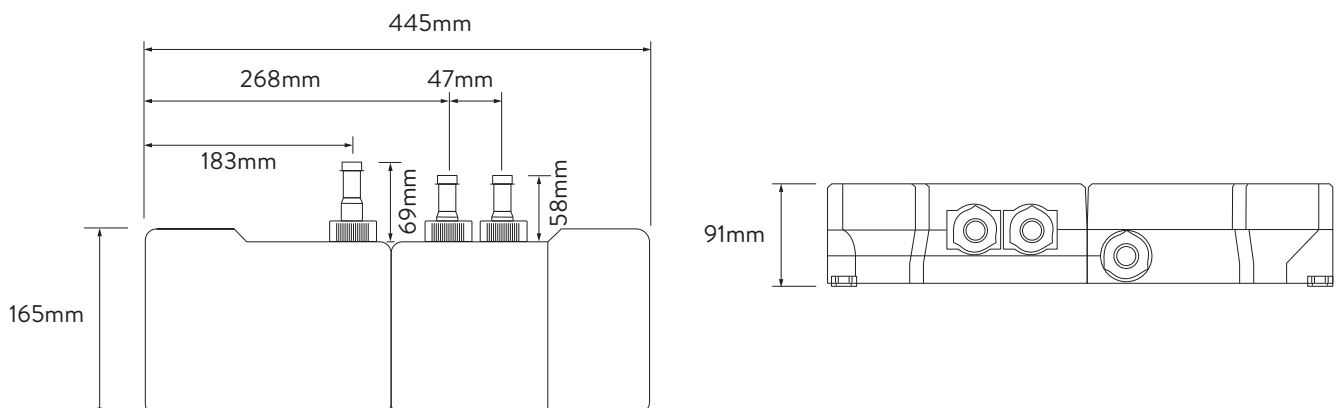

AQUALISA

ISYSTEM™

EXPOSED

ISD.A2.EV.14

WITH ADJUSTABLE HEAD - GRAVITY PUMPED

TECHNICAL SPECIFICATIONS

Minimum pressure requirements	Processor must be sited no higher than the base level of the cold water cistern (Gravity Pumped)
Maximum pressure requirements	1bar (Gravity)
Processor inlet fitting connections	15mm push fit
Valve inlet centres	48mm
Inlet supply positions	Hot right, cold left
Processor outlet fitting connection	15mm push fit
Permissible processor sitting location	Loft, airing cupboard, under bath
Supply temperature	Cold inlet temperature 1°C (minimum) Cold inlet temperature 15°C (maximum) Hot inlet temperature 65°C (maximum)
Water system	Gravity
Features	One touch start/stop control
	LED display indicates when pre-selected temperature has been reached
	Boost button for enhanced flow
	Compatible with wired remote control
Colour	Chrome
Guarantee period	5-year guarantee – shower unit
	2-year guarantee – shower head and kit
Approvals	CE Marking
	BEAB