

N 50
195CAQ6NOB
CEILING HOOD
STAINLESS STEEL
90 CM WIDE

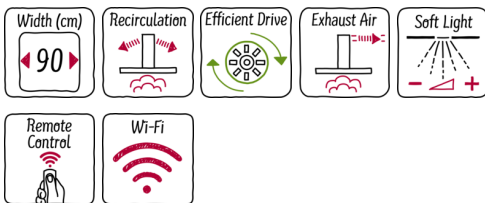

A



Flush with the ceiling, the stylish integrated ceiling hood leaves room for an open and clear kitchen

- ✓ Hob-Hood Control: conveniently control the hood directly from the hob (with Wi-Fi enabled hob)
- ✓ Dimmer Function – dim the LED light conveniently with the button on the remote control
- ✓ Remote Control – comfortably control the ceiling hood with a remote
- ✓ Interval Ventilation – automatically ventilates every hour for crisp, clean air
- ✓ CleanAir Recirculation Filter (separate accessory): nothing but clean air thanks to the premium recirculation filter with high odour reduction (ca. 95%). Regenerative filter also available.

Features

Technical Data

Approval certificates : CE, VDE
 Length of electrical supply cord (cm) : 130
 Required niche size for installation (HxWxD) : 299mm x 888mm x 487mm
 Minimum distance above an electric hob : 650
 Minimum distance above a gas hob : 650
 Net weight (kg) : 27.652
 Type of control : Electronic
 Number of speed settings : 3-stage + 2 intensive
 Maximum output air extraction (m³/h) : 459
 Boost position output recirculating (m³/h) : 565
 Maximum output recirculating air (m³/h) : 422
 Boost position air extraction (m³/h) : 798
 Number of lights (Stck) : 4
 Noise level (dB(A) re 1 pW) : 56
 Diameter of air outlet (mm) : 150
 Grease filter material : Washable stainless steel
 EAN code : 4242004235705
 Connection rating (W) : 160
 Voltage (V) : 220-240
 Frequency (Hz) : 50; 60
 Plug type : GB plug
 Installation type : Island

Optional accessories

Z50XXP0X0 CleanAir act.carbon filter regenerative
 Z5170X1 CleanAir active carbon filter spare part
 Z52JCC0N0 CleanAir Recirculation module
 Z52JCC0W0 CleanAir Recirculation module
 Z52JCD0N0 CleanAir Recirculation module regener.
 Z52JCD0W0 CleanAir Recirculation module regener.



4 242004 235705

N 50
195CAQ6NOB
CEILING HOOD
STAINLESS STEEL
90 CM WIDE

Features

Key performance features:

- Energy Efficiency Class: A (at a range of energy efficiency classes from A++ to E)*
- Extraction rate according to EN 61591 ø 15 cm:
max. Normal use 458 m³/h
Intensive 798 m³/h
- Noise max. Normal Level: 56 dB*

Special features

- Hob-Hood control (with Wi-Fi enabled hob)
- Remote Monitoring and Control for connected home appliances and operation via smartphone or tablet (only in countries where Home Connect service is available)
- The Home Connect functionality can be extended by integrating numerous applications from external cooperation partners (partnerships)
- Voice Control enabled via popular voice assistants (only in countries where this service is available)
- Interval function: available via Home Connect
- Silence function: available via Home Connect

Features

- 3 power levels and 2 intensive settings
- Infrared remote control
- LED display
- Twin channel high performance fan motor
- Efficient BLDC technology
- 4 x 3W LED lights
- softLight with dimmer function
- Interval operation
- Automatic after running (10 minutes)
- Automatic intensive revert (6mins)
- 2 metal grease filter cassettes
- Saturation indicator for metal and charcoal filter
- easy to clean Inner frame
- Rim ventilation

Design

- Stainless steel
- For ceiling mounted installation
- Rotatable motor: possible to position the air outlet on all four sides
- Stainless steel filter cover, metal grease filter
- Electronic controls

Performance/technical information

- Suitable for ducted extraction and recirculation
- For recirculated extraction CleanAir recirculating kit (accessory) needed
- Extraction rate according to EN 61591 ø 15 cm:
max. Normal use 458 m³/h
Intensive 798 m³/h
- Extraction rate according to EN 61591 max. 458 m³/h
- Noise level according to EN 60704-3 and EN 60704-2-13 at max. normal use exhaust air: 56 dB(A) re 1 pW (43 dB(A) re 20 µPa sound pressure)
- Noise level according to EN 60704-3 and EN 60704-2-13 exhaust air:
Max. normal use: 56 dB(A) re 1 pW (43 dB(A) re 20 µPa sound pressure)
Intensive: 68 dB(A) re 1 pW (55 dB(A) re 20 µPa sound pressure)
- Noise level according to EN 60704-3 and EN 60704-2-13 at maximum normal setting: extraction rate: 56 dB (A) re 1pW
- Noise max. Normal Level: 56 dB*
- Power rating: 160 W
- Light Intensity: 659 lux
- Colour Temperature: 3500 K
- Electrical cable length 1.3 m
- Diameter pipe ø 150 mm (ø 150 mm enclosed)
- Dimensions exhaust air (HxWxD): 300-300 x 900 x 500 mm
- Energy Efficiency Class: A (at a range of energy efficiency classes from A++ to E)*
- Blower Efficiency Class: A*
- Lighting Efficiency Class: A*
- Grease Filtering Efficiency Class: E*
- Average Energy Consumption: 35.3 kWh/year*

Optional accessories

- Recirculating kit

* In accordance with the EU-Regulation No 65/2014

N 50
195CAQ6NOB
CEILING HOOD
STAINLESS STEEL
90 CM WIDE

Dimensioned drawings

The fan outlet can be turned
in all four directions

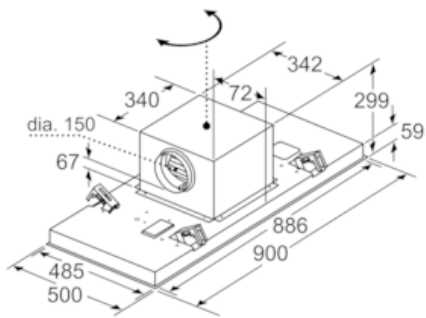

measurements in mm

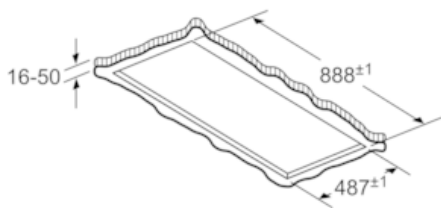

Never fit directly onto plasterboard or similar
lightweight construction materials of the
suspended ceiling. A suitable substructure
is required that is securely fixed to the
concrete ceiling.

measurements in mm