

N 50, Ceiling cooker hood, 90 cm, Stainless steel  
195CAQ6NOB



COOKING PASSION SINCE 1877



A

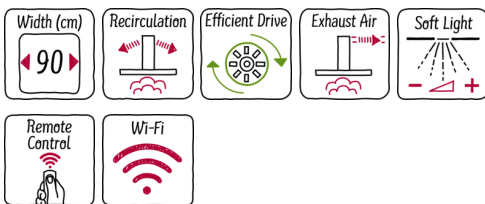

Flush with the ceiling, the stylish integrated ceiling hood leaves room for an open and clear kitchen

- ✓ Hob-Hood Control: conveniently control the hood directly from the hob (with Wi-Fi enabled hob)
- ✓ Dimmer Function – dim the LED light conveniently with the button on the remote control
- ✓ Remote Control – comfortably control the ceiling hood with a remote
- ✓ Interval Ventilation – automatically ventilates every hour for crisp, clean air
- ✓ CleanAir Recirculation Filter (separate accessory): nothing but clean air thanks to the premium recirculation filter with high odour reduction (ca. 95%). Regenerative filter also available.

#### Features

##### Technical Data

Approval certificates : CE, VDE  
 Length of electrical supply cord (cm) : 130  
 Required niche size for installation (HxWxD) : 299mm x 888mm x 487mm  
 Minimum distance above an electric hob : 650  
 Minimum distance above a gas hob : 650  
 Net weight (kg) : 21.116  
 Type of control : Electronic  
 Number of speed settings : 3-stage + 2 intensive  
 Maximum output air extraction (m<sup>3</sup>/h) : 459  
 Boost position output recirculating (m<sup>3</sup>/h) : 565  
 Maximum output recirculating air (m<sup>3</sup>/h) : 422  
 Boost position air extraction (m<sup>3</sup>/h) : 798  
 Number of lights (Stck) : 4  
 Noise level (dB(A) re 1 pW) : 56  
 Diameter of air outlet (mm) : 150  
 Grease filter material : Washable stainless steel  
 EAN code : 4242004235705  
 Connection rating (W) : 174  
 Voltage (V) : 220-240  
 Frequency (Hz) : 50; 60  
 Plug type : GB plug  
 Installation type : Island

#### Optional accessories

Z50XXP0X0 CleanAir act.carbon filter regenerative  
 Z5170X1 CleanAir active carbon filter spare part  
 Z52JCC0N0 CleanAir Recirculation module  
 Z52JCC0W0 CleanAir Recirculation module  
 Z52JCD0N0 CleanAir Recirculation module regener.  
 Z52JCD0W0 CleanAir Recirculation module regener.



4 242004 235705

# N 50, Ceiling cooker hood, 90 cm, Stainless steel

## 195CAQ6NOB

### Features

#### Key performance features:

- Energy Efficiency Class: A (at a range of energy efficiency classes from A+++ to D)
- Extraction rate according to EN 61591 ø 15 cm:  
max. Normal use 458 m<sup>3</sup>/h  
Intensive 798 m<sup>3</sup>/h
- Noise max. Normal Level: 56 dB\*

#### Special features

- Hob-Hood control (with Wi-Fi enabled hob)
- Remote Monitoring and Control for connected home appliances and operation via smartphone or tablet (only in countries where Home Connect service is available)
- The Home Connect functionality can be extended by integrating numerous applications from external cooperation partners (partnerships)
- Voice Control enabled via popular voice assistants (only in countries where this service is available)
- Interval function: available via Home Connect
- Silence function: available via Home Connect

#### Features

- 3 power levels and 2 intensive settings
- Infrared remote control
- LED display
- Twin channel high performance fan motor
- Efficient BLDC technology
- 4 x 3W LED lights
- softLight with dimmer function
- Interval operation
- Automatic after running (10 minutes)
- Automatic intensive revert (6mins)
- 2 metal grease filter cassettes
- Saturation indicator for metal and charcoal filter
- easy to clean Inner frame
- Rim ventilation

#### Design

- Stainless steel
- For ceiling mounted installation
- Rotatable motor: possible to position the air outlet on all four sides
- Stainless steel filter cover, metal grease filter
- Electronic controls

#### Performance/technical information

- Suitable for ducted extraction and recirculation
- For recirculated extraction CleanAir recirculating kit (accessory) needed
- Extraction rate according to EN 61591 ø 15 cm:  
max. Normal use 458 m<sup>3</sup>/h  
Intensive 798 m<sup>3</sup>/h
- Extraction rate according to EN 61591 max. 458 m<sup>3</sup>/h
- Noise level according to EN 60704-3 and EN 60704-2-13 at max. normal use exhaust air: 56 dB(A) re 1 pW (43 dB(A) re 20 µPa sound pressure)
- Noise level according to EN 60704-3 and EN 60704-2-13 exhaust air:  
Max. normal use: 56 dB(A) re 1 pW (43 dB(A) re 20 µPa sound pressure)  
Intensive: 68 dB(A) re 1 pW (55 dB(A) re 20 µPa sound pressure)
- Noise level according to EN 60704-3 and EN 60704-2-13 at maximum normal setting: extraction rate: 56 dB (A) re 1pW
- Noise max. Normal Level: 56 dB\*
- Power rating: 174 W
- Light Intensity: 659 lux
- Colour Temperature: 3500 K
- Electrical cable length 1.3 m
- Diameter pipe Ø 150 mm (Ø 150 mm enclosed)
- Dimensions exhaust air (HxWxD): 300-300 x 900 x 500 mm
- Energy Efficiency Class: A (at a range of energy efficiency classes from A+++ to D)
- Blower Efficiency Class: A\*
- Lighting Efficiency Class: A\*
- Grease Filtering Efficiency Class: E\*
- Average Energy Consumption: 34 kWh/year\*

#### Optional accessories

- Recirculating kit

\* In accordance with the EU-Regulation No 65/2014

N 50, Ceiling cooker hood, 90 cm, Stainless steel  
195CAQ6NOB

Dimensioned drawings

The fan outlet can be turned in all four directions

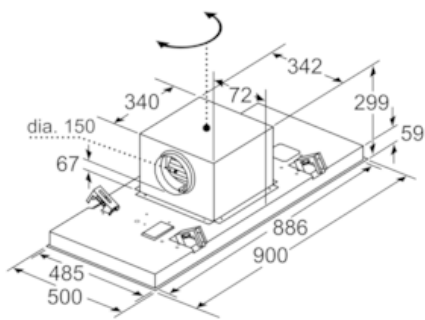

measurements in mm

measurements in mm  
Air recirculation

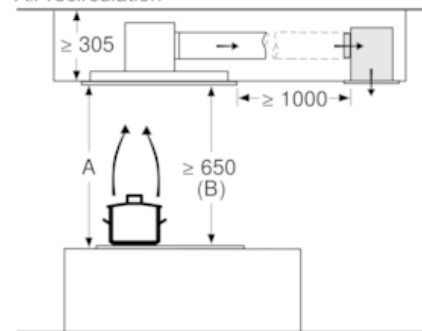

A: Optimum performance 700-1500  
B: From upper edge of pan support

measurements in mm  
Air extraction

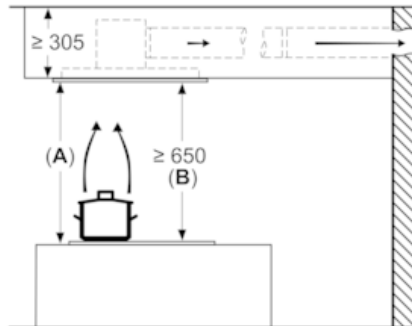

A: Optimum performance 700-1500  
B: From upper edge of pan support

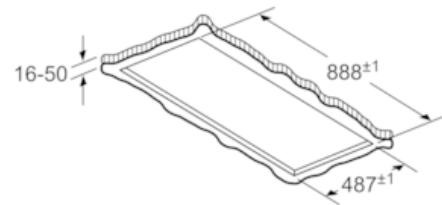

Never fit directly onto plasterboard or similar lightweight construction materials of the suspended ceiling. A suitable substructure is required that is securely fixed to the concrete ceiling.

measurements in mm

measurements in mm  
Air recirculation

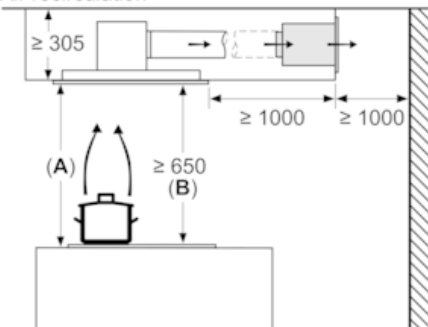

A: Optimum performance 700-1500  
B: From upper edge of pan support