

# Wickes

## BELT SANDER

**920W 76x533MM**



**PBS900G.1**  
**223740**

# CONTENTS

**GENERAL POWER TOOL SAFETY WARNINGS 3**

**SAFETY WARNINGS FOR SANDER 4**

**COMPONENT LIST 5**

**ACCESSORIES 6**

**TECHNICAL DATA 6**

**SYMBOLS 6**

**NOISE INFORMATION 7**

**OPERATING INSTRUCTIONS 8**

**WORKING HINTS 12**

**MAINTENANCE 12**

**ENVIRONMENTAL PROTECTION 12**

**PLUG REPLACEMENT (ONLY FOR REWIRABLE PLUG OF UK & IRELAND) 13**

**DECLARATION OF CONFORMITY 14**

# GENERAL POWER TOOL SAFETY WARNINGS

 **WARNING!** Read all safety warnings, instructions, illustrations and specifications provided with this power tool. Failure to follow all instructions listed below may result in electric shock, fire and/or serious injury.

## SAVE ALL WARNINGS AND INSTRUCTIONS FOR FUTURE REFERENCE.

The term "power tool" in the warnings refers to your mains-operated (corded) power tool or battery-operated (cordless) power tool.

### 1. WORK AREA SAFETY

- a) **Keep work area clean and well lit.** Cluttered or dark areas invite accidents.
- b) **Do not operate power tools in explosive atmospheres, such as in the presence of flammable liquids, gases or dust.** Power tools create sparks which may ignite the dust or fumes.
- c) **Keep children and bystanders away while operating a power tool.** Distractions can cause you to lose control.

### 2. ELECTRICAL SAFETY

- a) **Power tool plugs must match the outlet. Never modify the plug in any way. Do not use any adapter plugs with earthed (grounded) power tools.** Unmodified plugs and matching outlets will reduce risk of electric shock.
- b) **Avoid body contact with earthed or grounded surfaces, such as pipes, radiators, ranges and refrigerators.** There is an increased risk of electric shock if your body is earthed or grounded.
- c) **Do not expose power tools to rain or wet conditions.** Water entering a power tool will increase the risk of electric shock.
- d) **Do not abuse the cord. Never use the cord for carrying, pulling or unplugging the power tool. Keep cord away from heat, oil, sharp edges or moving parts.** Damaged or entangled cords increase the risk of electric shock.
- e) **When operating a power tool outdoors, use an extension cord suitable for outdoor use.** Use of a cord suitable for outdoor use reduces the risk of electric shock.
- f) **If operating a power tool in a damp location is unavoidable, use a residual current device (RCD) protected supply.** Use of an RCD reduces the risk of electric shock.

### 3. PERSONAL SAFETY

- a) **Stay alert, watch what you are doing and use common sense when operating a power tool. Do not use a power tool while you are tired or under the influence of drugs, alcohol or medication.** A moment of inattention while operating power tools may result in serious personal injury.
- b) **Use personal protective equipment. Always wear eye protection.** Protective equipment such as dust mask, non-skid safety shoes, hard hat, or hearing protection used for appropriate conditions will reduce personal injuries.
- c) **Prevent unintentional starting. Ensure the switch is in the off-position before connecting to power source and/or battery pack, picking up or carrying the tool.** Carrying power tools with your finger on the switch or energising power tools that have the switch on invites accidents.
- d) **Remove any adjusting key or wrench before turning the power tool on.** A wrench or a key left attached to a rotating part of the power tool may result in personal injury.
- e) **Do not overreach. Keep proper footing and balance at all times.** This enables better control of the power tool in unexpected situations.
- f) **Dress properly. Do not wear loose clothing or jewellery. Keep your hair and clothing away from moving parts.** Loose clothes, jewellery or long hair can be caught in moving parts.
- g) **If devices are provided for the connection of dust extraction and collection facilities, ensure these are connected and properly used.** Use of dust collection can reduce dust-related hazards.
- h) **Do not let familiarity gained from frequent use of tools allow you to become complacent and ignore tool safety principles.** A careless action can cause severe injury within a fraction of a second.

### 4. POWER TOOL USE AND CARE

- a) **Do not force the power tool. Use the correct power tool for your application.** The correct power tool will do the job better and safer at the rate for which it was designed.
- b) **Do not use the power tool if the switch does not turn it on and off.** Any power tool that cannot be controlled with the switch is dangerous and must be repaired.
- c) **Disconnect the plug from the power source and/ or remove the battery pack, if detachable, from**

**the power tool before making any adjustments, changing accessories, or storing power tools.** *Such preventive safety measures reduce the risk of starting the power tool accidentally.*

- d) Store idle power tools out of the reach of children and do not allow persons unfamiliar with the power tool or these instructions to operate the power tool.** *Power tools are dangerous in the hands of untrained users.*
- e) Maintain power tools and accessories. Check for misalignment or binding of moving parts, breakage of parts and any other condition that may affect the power tool's operation. If damaged, have the power tool repaired before use.** *Many accidents are caused by poorly maintained power tools.*
- f) Keep cutting tools sharp and clean.** *Properly maintained cutting tools with sharp cutting edges are less*

*likely to bind and are easier to control.*

- g) Use the power tool, accessories and tool bits etc. in accordance with these instructions, taking into account the working conditions and the work to be performed.** *Use of the power tool for operations different from those intended could result in a hazardous situation.*
  - h) Keep handles and grasping surfaces dry, clean and free from oil and grease.** *Slippery handles and grasping surfaces do not allow for safe handling and control of the tool in unexpected situations.*
- 5. SERVICE**
- a) Have your power tool serviced by a qualified repair person using only identical replacement parts.** *This will ensure that the safety of the power tool is maintained.*

## SAFETY WARNINGS FOR BELT SANDER

Hold power tool by insulated gripping surfaces, take care not to damage the power supply cord. Cutting a "live" wire may make exposed metal parts of the power tool "live" and could give the operator an electric shock.

# COMPONENT LIST

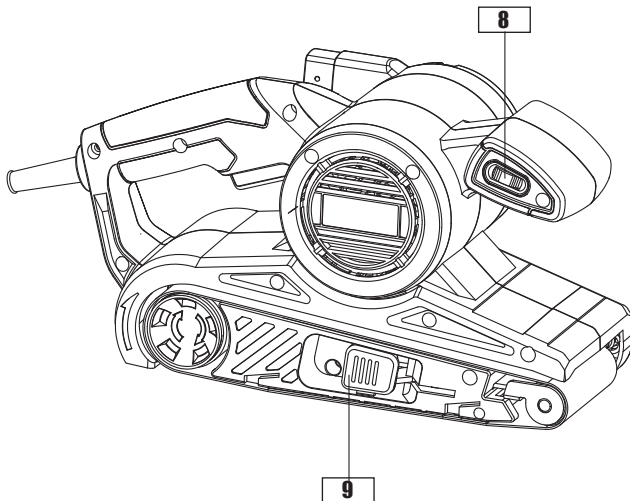
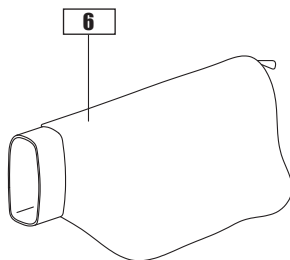
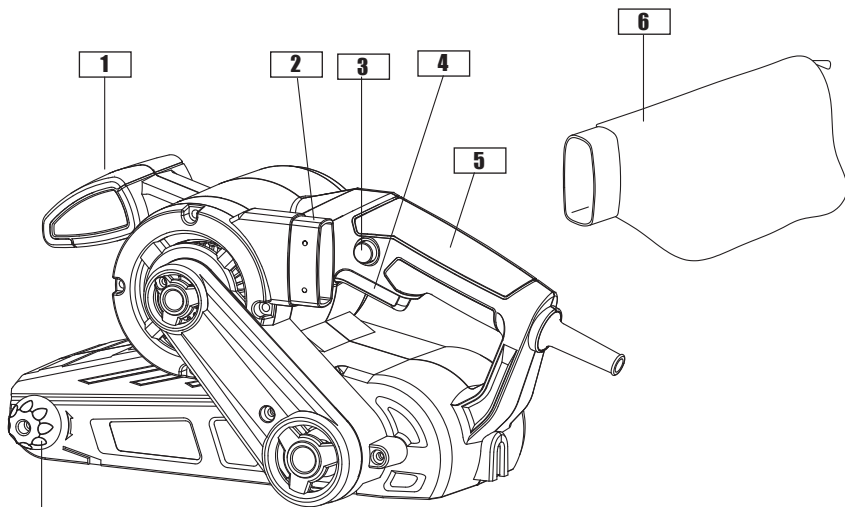

- 1** Front handle
- 2** Dust exhaust outlet
- 3** Lock on button
- 4** On/Off switch
- 5** Rear handle

- 6** Dust bag
- 7** Belt tracking adjustment knob
- 8** Variable speed control
- 9** Belt tension release lever

## ACCESSORIES

|                         |   |
|-------------------------|---|
| Dust extraction adapter | 1 |
| Dust bag                | 1 |
| 80 Grit sanding belt    | 1 |

We recommend that you purchase your accessories from the same store that sold you the tool. Use good quality accessories marked with a well-known brand name. Choose the type according to the work you intend to undertake. Refer to the accessory packaging for further details. Store personnel can assist you and offer advice.

## TECHNICAL DATA

|                    |                |
|--------------------|----------------|
| Voltage            | 230-240V~50 Hz |
| Power              | 920 W          |
| No load belt speed | 200-380 m/min  |
| Sanding belt size  | 76 x 533 mm    |
| Protection class   | □/II           |
| Machine weight     | 2.95 kg        |

## SYMBOLS



To reduce the risk of injury, read all of this instruction manual



Warning



Wear ear protection



Wear eye protection



Wear dust mask



Double insulated



Waste electrical products must not be disposed of with household waste. Please recycle where facilities exist. Check with your local authorities or retailer for recycling advice.



Wear protective gloves

# NOISE INFORMATION

A weighted sound pressure

A weighted sound power

$K_{pA}$  &  $K_{wA}$

Wear ear protection when sound pressure is over:

$L_{pA}$ : 82dB(A)

$L_{wA}$ : 93dB(A)

3.0dB(A)

80dB(A) 

# VIBRATION INFORMATION

|  |  |
|--|--|
| Vibration total values (triax vector sum) determined according to EN60745: |  |
| Vibration value emissioa   | Vibration emission value $a_h = 5.08m/s^2$ |
|  | Uncertainty $K=1.5m/s^2$                   |

The declared vibration total value may be used for comparing one tool with another, and may also be used in a preliminary assessment of exposure.

 **WARNING!** The vibration emission value during actual use of the power tool can differ from the declared value depending on the ways in which the tool is used dependant on the following examples and other variations on how the tool is used:

How the tool is used and the materials being cut or drilled.

The tool being in good condition and well maintained.

The use the correct accessory for the tool and ensuring it is sharp and in good condition.

The tightness of the grip on the handles and if any anti vibration accessories are used.

And the tool is being used as intended by its design and these instructions.

**This tool may cause hand-arm vibration syndrome if its use is not adequately managed.**

 **WARNING!** To be accurate, an estimation of exposure level in the actual conditions of use should also take account of all parts of the operating cycle such as the times when the tool is switched off and when it is running idle but not actually doing the job. This may significantly reduce the exposure level over the total working period, helping to minimize your vibration exposure risk.

ALWAYS use sharp sanding sheets.

Maintain this tool in accordance with these instructions and keep well lubricated (where appropriate).

If the tool is to be used regularly then invest in anti vibration accessories.

Avoid using tools in temperatures of 10°C or less.

Plan your work schedule to spread any high vibration tool use across a number of days.

# OPERATING INSTRUCTIONS

 **NOTE:** Before using the tool, read the instruction book carefully.

## 1. INSTALLING THE SANDING BELT (See Fig A1, A2)

 **WARNING!** Remove the mains plug from the socket before changing sanding belt.  
Pull the lever (9) to release the belt tension. Remove and fit a new belt over both rollers. Ensure the direction of rotation arrows on the belt and the sander are the same. Close the lever to tension the belt.

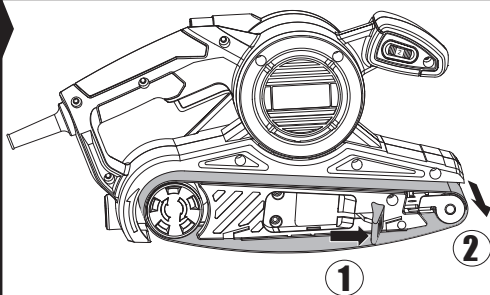

Fig. A1

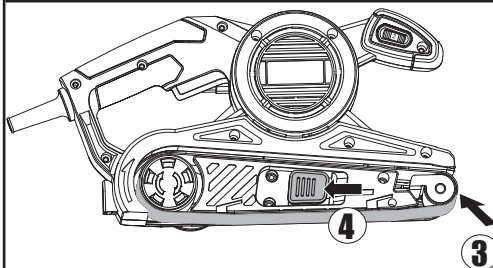



Fig. A2

## 2. BELT CENTERING CONTROL (See Fig. B )

 **WARNING!** Wear eye protection before carrying out a belt centering adjustment.  
Turn the machine upside down, hold it firmly with one hand, start the tool and release the switch immediately after observing tracking of sanding belt. If the sanding belt runs outward, turn tracking adjustment knob (7) counter-clockwise, and clockwise if the sanding belt runs inward. Adjust the sanding belt until the outer edge of the sanding belt is even with the outer edge of the base-plate. Belt life will be greatly increased by keeping the tracking adjustment set properly.

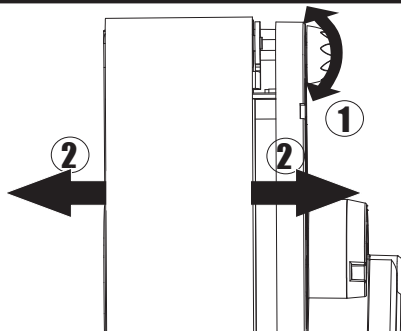

Fig. B



### 3. DUST BAG(See Fig. C1, C2)

You must use the dust bag provided to collect the dust produced during sanding. To attach, insert the dust bag (6) into the dust extraction outlet (2). Make sure the dots of the outlet are locked in the slot of the dust bag. When the dust bag is full, remove and empty by opening the zip on the dust bag (5).

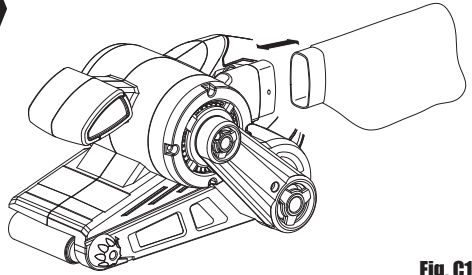

Fig. C1

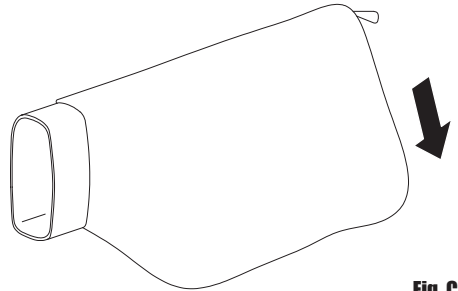

Fig. C2

### 4. SAFETY ON-OFF SWITCH(See Fig. D)

#### ON/OFF SWITCH

Depress to start and release to stop your tool.

#### SWITCH LOCK-ON BUTTON

Depress on/off switch (4) then lock on button (3). Your tool is now locked on for continuous use. To switch off your tool just depress and release the on/off switch.

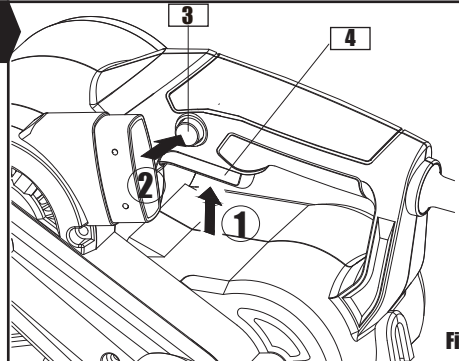

Fig. D

## 5. VARIABLE SPEED CONTROL(See Fig. E)

Adjust the variable speed control dial (8) to increase or decrease the speed according to the material and sanding belt specification to be used (also possible during no load operation). See the table below for general guidance on speed selection. Avoid prolonged use at very low speed as this may damage your sander.

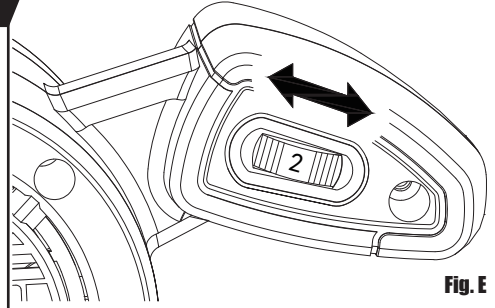

Fig. E

| Material      | Speed selection | Belt Grit |
|---------------|-----------------|-----------|
| Solid         | 5-6             | 80        |
| Veneer        | 2-4             | 150       |
| Chipboard     | 1-5             | 60/80     |
| Plastics      | 2-5             | 100       |
| Steel         | 5-6             | 80        |
| Paint Removal | 6               | 40/60     |
| Balsa Wood    | 1-3             | 100       |
| Acrylic       | 1-2             | 100       |

## 6. OPERATING THE TOOL(See Fig. F)

Keep the sanding belt and the workpiece surface parallel, hold the rear handle (5) and the front handle (1) firmly with your hands, and move the tool forward and backward.

**⚠ ATTENTION:** Do not press down too hard on your tool, apply only enough pressure to allow adequate control. Too much pressure will cause the speed to drop abnormally or the motor to become too hot, thus damaging the workpiece and the tool. If you see some sparks flashing in the ventilation slots do not panic this is normal and will not damage the tool.

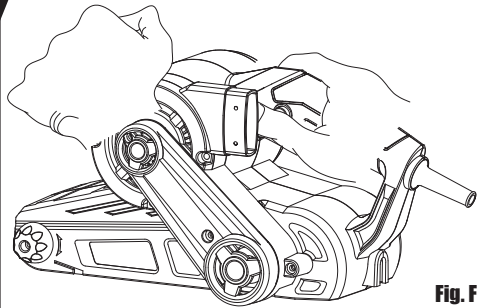

Fig. F

## 7. INSPECTING THE SANDING BELT

Since continued use of a worn-out sanding belt will degrade efficiency, replace the sanding belt as soon as excessive wear is observed.

## 8. DRIVE BELT REPLACEMENT (See Fig G1, G2)

**WARNING!** Remove the mains plug from the socket before carrying out a drive belt replacement. Do not attempt to remove the drive belt until the belt wheel has cooled down. Remove the screws and the belt cover as shown. Carefully cut the drive belt if not already broken and remove from your belt sander. Fit your new drive belt around the large pulley. Then install onto the small pulley by rotating clockwise and pushing the drive belt shown around the small pulley at the same time. The drive belt will be a tight fit. Fit the belt cover and the screws.

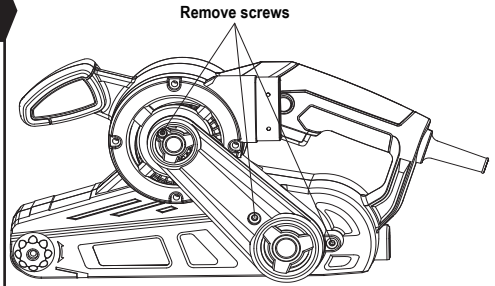

Fig. G1

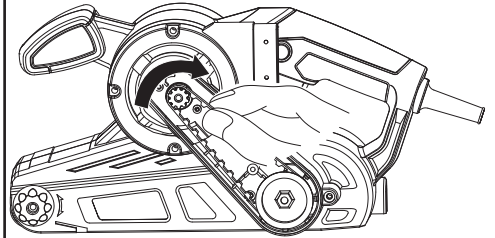

Fig. G2

## WORKING HINTS FOR YOUR BELT SANDER

If your power tool becomes too hot, especially when used at low speed, set the speed to maximum and run with no load for 2-3 minutes to cool the motor.

Avoid prolonged usage at very low speed.

Always use a sanding belt suited to the material you wish to sand.

Always ensure the work-piece is firmly held or clamped to prevent movement.

Support large panels close to the sanding area.

Any movement of the material may affect the quality of the sanding finish.

Start your sander before sanding and turn off only after stopping .

For best results sand wood in the direction of the grain.

Do not start sanding without the sanding belt fitted.

Empty the dust bag every 5 minutes or sooner to ensure efficient dust collection.

## MAINTENANCE

Remove the plug from the socket before carrying out any adjustment, servicing or maintenance.

Your power tool requires no additional lubrication or maintenance.

There are no user serviceable parts in your power tool.

Never use water or chemical cleaners to clean your power tool. Wipe clean with a dry cloth.

Always store your power tool in a dry place.

Keep the motor ventilation slots clean.

Keep all working controls free of dust.

Occasionally you may see sparks through the ventilation slots. This is normal.

If the supply cord is damaged, it must be replaced by the manufacturer, its service agent or similarly qualified persons in order to avoid a hazard.

## ENVIRONMENTAL PROTECTION



Waste electrical products should not be disposed of with household waste. Please recycle where facilities exist. Check with your Local Authority or retailer for recycling advice.

## PLUG REPLACEMENT (ONLY FOR REWIRABLE PLUG OF UK & IRELAND)

If you need to replace the fitted plug then follow the instructions below.

### IMPORTANT

The wires in the mains lead are colored in accordance with the following code:

Blue = Neutral

Brown = Live

As the colors of the wires in the mains lead of this appliance may not correspond with the colored markings identifying the terminals in your plug, proceed as follows. The wire which is colored blue must be connected to the terminal which is marked with N. The wire which is colored brown must be connected to the terminal which is marked with L.

### Warning!

Never connect live or neutral wires to the earth terminal of the plug. Only fit an approved 13A BS1363/A plug and the correct rated fuse.

Note: If a moulded plug is fitted and has to be removed take great care in disposing of the plug and severed cable, it must be destroyed to prevent engaging into a socket.

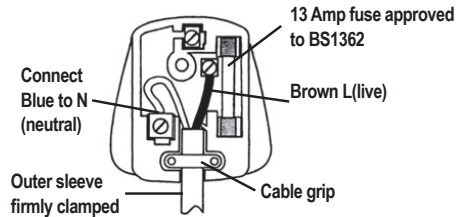

# DECLARATION OF CONFORMITY

We,  
**Wickes Building Supplies Limited**

**Declare that this product: BELT SANDER**

*Description and SKU code: 223740*

**Complies with the following Directives and Regulations:**

2006/42/EC, Machinery Directive

2014/30/EU, Electromagnetic Compatibility Directive

2011/65/EU & (EU)2015/863 (RoHS),Restriction of Hazardous Substances Directive

**and conforms to the following standards:**

*Standards specific to this product:*

**EN 62841-1**

**EN 62841-2-4**

**EN 55014-1**

**EN 55014-2**

**EN 61000-3-2**

**EN 61000-3-3**

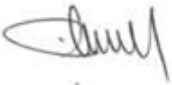

28<sup>th</sup> January, 2021

Philip Ansell

Category Technical Manager

Wickes

Vision House

19 Colonial Way

Watford

WD24 4JL”



**Customer Helpline 0345 2005409**