

# Wickes

## COMPOUND MITRE SAW

**210MM**



**BMS2101**  
**223748**

# CONTENTS

**GENERAL POWER TOOL SAFETY WARNINGS 3**

**COMPONENT LIST 6**

**ACCESSORIES 7**

**TECHNICAL DATA 7**

**SYMBOLS 8**

**NOISE INFORMATION 9**

**OPERATING INSTRUCTIONS 10**

**MAINTENANCE 18**

**ENVIRONMENTAL PROTECTION 20**

**PLUG REPLACEMENT (ONLY FOR REWIRABLE PLUG OF UK & IRELAND) 20**

**DECLARATION OF CONFORMITY 21**

# ORIGINAL INSTRUCTION

## GENERAL POWER TOOL SAFETY WARNINGS

 **WARNING: Read all safety warnings, instructions, illustrations and specifications provided with this power tool.** Failure to follow all instructions listed below may result in electric shock, fire and/or serious injury.

### SAVE ALL WARNINGS AND INSTRUCTIONS FOR FUTURE REFERENCE.

The term "power tool" in the warnings refers to your mains-operated (corded) power tool or battery-operated (cordless) power tool.

#### 1) Work area safety

- a) **Keep work area clean and well lit.** Cluttered or dark areas invite accidents.
- b) **Do not operate power tools in explosive atmospheres, such as in the presence of flammable liquids, gases or dust.** Power tools create sparks which may ignite the dust or fumes.
- c) **Keep children and bystanders away while operating a power tool.** Distractions can cause you to lose control.

#### 2) Electrical safety

- a) **Power tool plugs must match the outlet. Never modify the plug in any way. Do not use any adapter plugs with earthed (grounded) power tools.** Unmodified plugs and matching outlets will reduce risk of electric shock.
- b) **Avoid body contact with earthed or grounded surfaces, such as pipes, radiators, ranges and refrigerators.** There is an increased risk of electric shock if your body is earthed or grounded.
- c) **Do not expose power tools to rain or wet conditions.** Water entering a power tool will increase the risk of electric shock.
- d) **Do not abuse the cord. Never use the cord for carrying, pulling or unplugging the power tool. Keep cord away from heat, oil, sharp edges or moving parts.** Damaged or entangled cords increase the risk of electric shock.
- e) **When operating a power tool outdoors, use an extension cord suitable for outdoor use.** Use of a cord suitable for outdoor use reduces the risk of electric shock.
- f) **If operating a power tool in a damp location is unavoidable, use a residual current device (RCD) protected supply.** Use of an RCD reduces the risk of electric shock.

#### 3) Personal safety

- a) **Stay alert, watch what you are doing and use common sense when operating a power tool.** Do not use a power tool while you are tired or under the influence of drugs, alcohol or medication. A moment of inattention while operating power tools may result in serious personal injury.
  - b) **Use personal protective equipment. Always wear eye protection.** Protective equipment such as dust mask, non-skid safety shoes, hard hat, or hearing protection used for appropriate conditions will reduce personal injuries.
  - c) **Prevent unintentional starting. Ensure the switch is in the off-position before connecting to power source and/or battery pack, picking up or carrying the tool.** Carrying power tools with your finger on the switch or energising power tools that have the switch on invites accidents.
  - d) **Remove any adjusting key or wrench before turning the power tool on.** A wrench or a key left attached to a rotating part of the power tool may result in personal injury.
  - e) **Do not overreach. Keep proper footing and balance at all times.** This enables better control of the power tool in unexpected situations.
  - f) **Dress properly. Do not wear loose clothing or jewellery. Keep your hair and clothing away from moving parts.** Loose clothes, jewellery or long hair can be caught in moving parts.
  - g) **If devices are provided for the connection of dust extraction and collection facilities, ensure these are connected and properly used.** Use of dust collection can reduce dust-related hazards.
  - h) **Do not let familiarity gained from frequent use of tools allow you to become complacent and ignore tool safety principles.** A careless action can cause severe injury within a fraction of a second.
- #### 4) Power tool use and care
- a) **Do not force the power tool. Use the correct power tool for your application.** The correct power tool will do the job better and safer at the rate for which it was designed.
  - b) **Do not use the power tool if the switch does not turn it on and off.** Any power tool that cannot be controlled with the switch is dangerous and must be repaired.
  - c) **Disconnect the plug from the power source**

**and/or remove the battery pack, if detachable, from the power tool before making any adjustments, changing accessories, or storing power tools.** *Such preventive safety measures reduce the risk of starting the power tool accidentally.*

- d) Store idle power tools out of the reach of children and do not allow persons unfamiliar with the power tool or these instructions to operate the power tool.** *Power tools are dangerous in the hands of untrained users.*
  - e) Maintain power tools and accessories. Check for misalignment or binding of moving parts, breakage of parts and any other condition that may affect the power tool's operation. If damaged, have the power tool repaired before use.** *Many accidents are caused by poorly maintained power tools.*
  - f) Keep cutting tools sharp and clean.** *Properly maintained cutting tools with sharp cutting edges are less likely to bind and are easier to control.*
  - g) Use the power tool, accessories and tool bits etc. in accordance with these instructions, taking into account the working conditions and the work to be performed.** *Use of the power tool for operations different from those intended could result in a hazardous situation.*
  - h) Keep handles and grasping surfaces dry, clean and free from oil and grease.** *Slippery handles and grasping surfaces do not allow for safe handling and control of the tool in unexpected situations.*
- 5) Service**
- a) Have your power tool serviced by a qualified repair person using only identical replacement parts.** *This will ensure that the safety of the power tool is maintained.*

## SAFETY INSTRUCTIONS FOR MITRE SAWS

- a) Mitre saws are intended to cut wood or wood-like products, they cannot be used with abrasive cut-off wheels for cutting ferrous material such as bars, rods, studs, etc.** *Abrasive dust causes moving parts such as the lower guard to jam. Sparks from abrasive cutting will burn the lower guard, the kerf insert and other plastic parts.*
- b) Use clamps to support the workpiece whenever possible. If supporting the workpiece by hand, you must always keep your hand at least 100 mm from either side of the saw blade. Do not use this saw to cut pieces that are too small to be securely clamped or held by hand.** *If your hand is placed too close to the saw blade, there is an increased risk of injury from blade contact.*
- c) The workpiece must be stationary and clamped or held against both the fence and the table. Do not feed the workpiece into the blade or cut "freehand" in any way.** *Unrestrained or moving workpieces could be thrown at high speeds, causing injury.*
- d) Push the saw through the workpiece. Do not pull the saw through the workpiece. To make a cut, raise the saw head and pull it out over the workpiece without cutting, start the motor, press the saw head down and push the saw through the workpiece.** *Cutting on the pull stroke is likely to cause the saw blade to climb on top of the workpiece and violently throw the blade assembly towards the operator.*
- e) Never cross your hand over the intended line of cutting either in front or behind the saw blade.** *Supporting the workpiece "cross handed" i.e. holding the workpiece to the right of the saw blade with your left hand or vice versa is very dangerous.*
- f) Do not reach behind the fence with either hand closer than 100 mm from either side of the saw blade, to remove wood scraps, or for any other reason while the blade is spinning.** *The proximity of the spinning saw blade to your hand may not be obvious and you may be seriously injured.*
- g) Inspect your workpiece before cutting. If the workpiece is bowed or warped, clamp it with the outside bowed face toward the fence. Always make certain that there is no gap between the workpiece, fence and table along the line of the cut.** *Bent or warped workpieces can twist or shift and may cause binding on the spinning saw blade while cutting. There should be no nails or foreign objects in the workpiece.*
- h) Do not use the saw until the table is clear of all tools, wood scraps, etc., except for the workpiece.** *Small debris or loose pieces of wood or other objects that contact the revolving blade can be thrown with high speed.*
- i) Cut only one workpiece at a time.** *Stacked multiple workpieces cannot be adequately clamped or braced and may bind on the blade or shift during cutting.*

- j) **Ensure the mitre saw is mounted or placed on a level, firm work surface before use.** *A level and firm work surface reduces the risk of the mitre saw becoming unstable.*
- k) **Plan your work. Every time you change the bevel or mitre angle setting, make sure the adjustable fence is set correctly to support the workpiece and will not interfere with the blade or the guarding system.** *Without turning the tool "ON" and with no workpiece on the table, move the saw blade through a complete simulated cut to assure there will be no interference or danger of cutting the fence.*
- l) **Provide adequate support such as table extensions, saw horses, etc. for a workpiece that is wider or longer than the table top.** *Workpieces longer or wider than the mitre saw table can tip if not securely supported. If the cut-off piece or workpiece tips, it can lift the lower guard or be thrown by the spinning blade.*
- m) **Do not use another person as a substitute for a table extension or as additional support.** *Unstable support for the workpiece can cause the blade to bind or the workpiece to shift during the cutting operation pulling you and the helper into the spinning blade.*
- n) **The cut-off piece must not be jammed or pressed by any means against the spinning saw blade.** *If confined, i.e. using length stops, the cut-off piece could get wedged against the blade and thrown violently.*
- o) **Always use a clamp or a fixture designed to properly support round material such as rods or tubing.** *Rods have a tendency to roll while being cut, causing the blade to "bite" and pull the work with your hand into the blade.*
- p) **Let the blade reach full speed before contacting the workpiece.** *This will reduce the risk of the workpiece being thrown.*
- q) **If the workpiece or blade becomes jammed, turn the mitre saw off. Wait for all moving parts to stop and disconnect the plug from the power source and/or remove the battery pack. Then work to free the jammed material.** *Continued sawing with a jammed workpiece could cause loss of control or damage to the mitre saw.*
- r) **After finishing the cut, release the switch, hold the saw head down and wait for the blade to stop before removing the cut-off piece.** *Reaching with your hand near the coasting blade is dangerous.*
- s) **Use only saw blades recommended by the manufacturer, which conform to EN 847-1, if intended for wood and analogous materials.**

# COMPONENT LIST

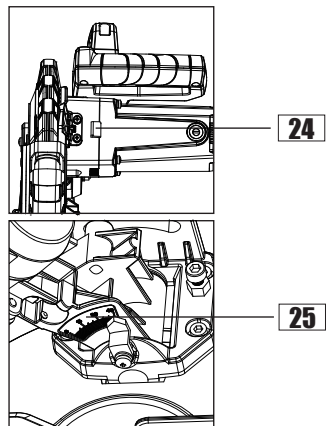
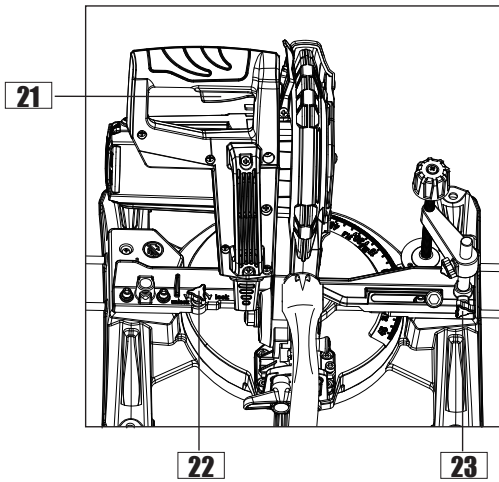
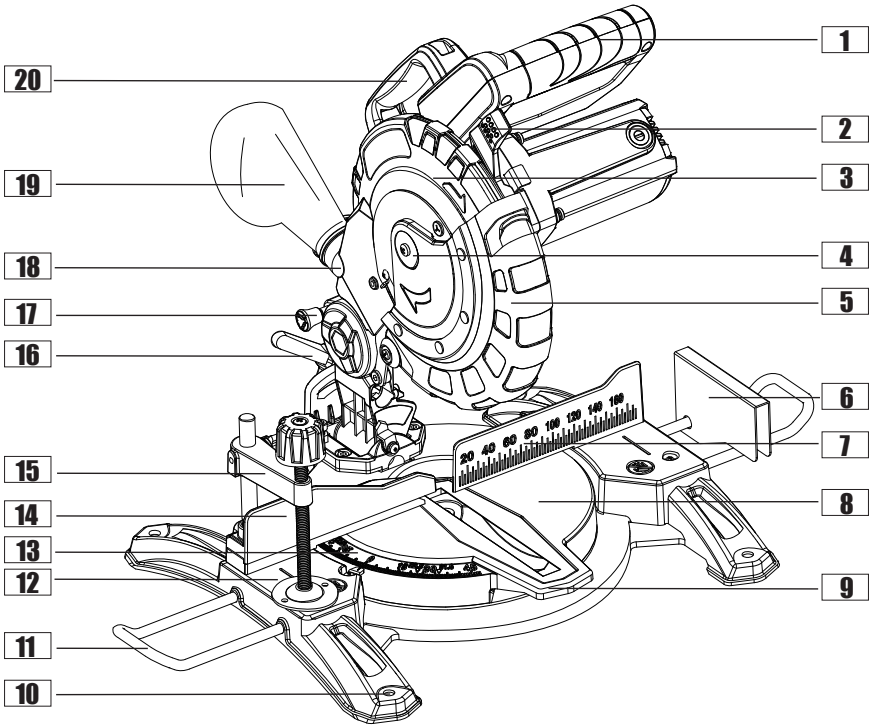

<b>1</b>	Operating handle
<b>2</b>	Lower blade lock lever
<b>3</b>	Upper fixed guard
<b>4</b>	Blade bolt cover
<b>5</b>	Lower rotating guard
<b>6</b>	Brace
<b>7</b>	Fence
<b>8</b>	Rotating mitre table
<b>9</b>	Mitre table adjusting handle
<b>10</b>	Mounting hole (x4)
<b>11</b>	Extension bar (x2)
<b>12</b>	Base plate
<b>13</b>	Mitre scale
<b>14</b>	Extended fence for bevel cutting

<b>15</b>	Work clamp
<b>16</b>	Bevel lock knob
<b>17</b>	Release knob
<b>18</b>	Dust extraction port
<b>19</b>	Dust bag
<b>20</b>	Carry handle
<b>21</b>	On/off switch
<b>22</b>	Mitre table lock knob
<b>23</b>	Work clamp lock knob
<b>24</b>	Spindle lock button
<b>25</b>	Bevel scale
<b>26</b>	Saw blade (See Fig. O2)
<b>27</b>	M5 Hex key for extended fence (See Fig. G1)
<b>28</b>	M8 Hex key for blade (See Fig. O3)

## ACCESSORIES

M5 Hex key for extended fence	1
M8 Hex key for blade	1
Brace	1
Extension bars	2
Work clamp	1
Dust bag	1
210mm blade	1

We recommend that you purchase your accessories from the same store that sold you the tool. Refer to the accessory packaging for further details. Store personnel can assist you and offer advice.

## TECHNICAL DATA

Rated voltage	230-240V~50Hz
Rated Input power	S1: 1450W, S6: 1800W
No load speed	5000/min
Bevel capacity	0-45°
Blade size	210mm
Protection class	□ / II
Machine weight	7.3kg
Cutting capacity	
Max cutting capacity mitre/bevel: 45°/90°	60*85mm
Max cutting capacity mitre/bevel: 0°/90°	60*120mm
Max cutting capacity mitre/bevel: 0°/45°	34*120mm
Max cutting capacity mitre/bevel: 45°/45°	34*85mm

# SYMBOLS



To reduce the risk of injury, read all of this instruction manual



Warning



Wear ear protection



Wear eye protection



Wear dust mask



Double insulated



Waste electrical products must not be disposed of with household waste. Please recycle where facilities exist. Check with your local authorities or retailer for recycling advice.



Keep hands away from the blade and mechanism



Lock



Unlock



# NOISE INFORMATION

A weighted sound pressure

A weighted sound power

$K_{pA}$  &  $K_{wA}$

**Wear ear protection.**

$L_{pA}$ : 97 dB(A)

$L_{wA}$ : 110 dB(A)

3.0 dB(A)

The declared noise emission value has been measured in accordance with a standard test method and may be used for comparing one tool with another.

The declared noise emission value may also be used in a preliminary assessment of exposure.

 **WARNING!** The noise emissions during actual use of the power tool can differ from the declared value depending on the ways in which the tool is used especially what kind of workpiece is processed dependant on the following examples and other variations on how the tool is used:

How the tool is used and the materials being cut or drilled.

The tool being in good condition and well maintained.

The use of the correct accessory for the tool and ensuring it is sharp and in good condition.

If any anti noise accessories are used.

And the tool is being used as intended by its design and these instructions.

 **WARNING!** To be accurate, an estimation of exposure level in the actual conditions of use should also take account of all parts of the operating cycle such as the times when the tool is switched off and when it is running idle but not actually doing the job. This may significantly reduce the exposure level over the total working period, helping to minimize your vibration exposure risk.

Always use a sharp blade.

Maintain this tool in accordance with these instructions and keep well lubricated (where appropriate).

If the tool is to be used regularly then invest in anti noise accessories.

# OPERATING INSTRUCTIONS



**NOTE:** Before using the tool, read the instruction book carefully.

## Intended Use

The machine is intended as a stationary machine for making straight lengthways and crossways cuts in wood. Horizontal mitre angles of 0° to +45° as well as vertical bevel angles of 0° to +45° are possible.

## ASSEMBLY



**WARNING:** To prevent the accidental starting that could cause possible serious personal injury, **ALWAYS** assemble all parts to your saw **BEFORE** connecting it to the power supply. The saw should **NEVER** be connected to a power supply when you are assembling parts, making adjustments, installing or removing blades, or when not in use.

### 1. DUST EXTRACTION PORT (SEE FIG. A)

To reduce build up of saw dust and maintain the cutting efficiency, saw dust collection can be achieved by connecting a vacuum dust collector or cleaner to the dust extraction port.

Alternatively, a dust bag is provided for use on your mitre saw. To install it, hold the dust bag by depressing both sides of the metal ring clip, and locate onto the dust extraction port, then you can loosen the ring clip. Ensure the dust bag is securely fastened before operating the saw. To empty the dust bag, remove it from the dust extraction port, open the dust bag by unzipping the slide fastener.

**NOTE:** To ensure optimal dust collecting, empty the dust bag when it becomes filled to approximately 2/3 of its capacity.

Fig. A

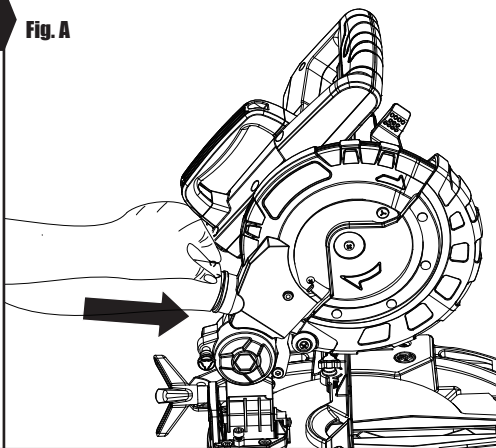

### 2. SIDE TABLE EXTENSIONS (SEE FIG. B1-B6)

Long work-pieces require extra supports. The supports should be placed along the work-piece so it does not sag. The support should allow the work-piece to lay flat on the base of the saw and work table during the cutting operation. Use the work clamp to secure the work-piece.

This mitre saw is provided with extension bars for both sides, and a brace for only one side. To install the side extension bars (Left & right) and the brace, follow the below instructions.

- 1) Loosen the screw on the side of the brace by turning it anti-clockwise. (See Fig. B1)
- 2) Attach the extension bar with the brace as shown in Fig. B2. Insert one end of the rail into the hole of the brace, the other end into the notch of the brace.
- 3) Loosen and remove the screw on the corner of the base plate using a screwdriver. (See Fig. B3)
- 4) Invert the mitre saw for better visibility. Align and insert the 2 ends of the extension bar into the 2 holes at the edge of the base plate. (See Fig. B4)
- 5) Re-tighten the screw on the corner of the base plate using a screwdriver to secure the extension bar. (See Fig. B5)
- 6) Position the brace upright as shown in Fig. B6.
- 7) Repeat step 3 to 5 for opposite extension bar without the brace.

**Fig. B1**

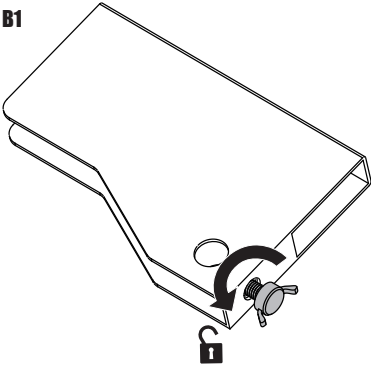

**Fig. B2**

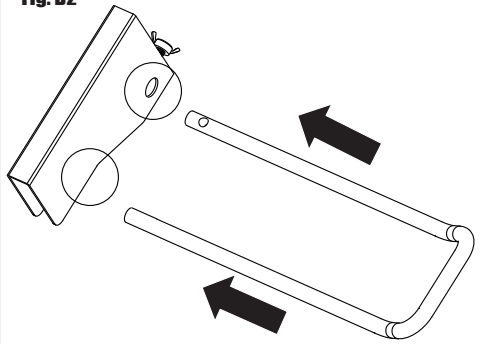

**Fig. B3**

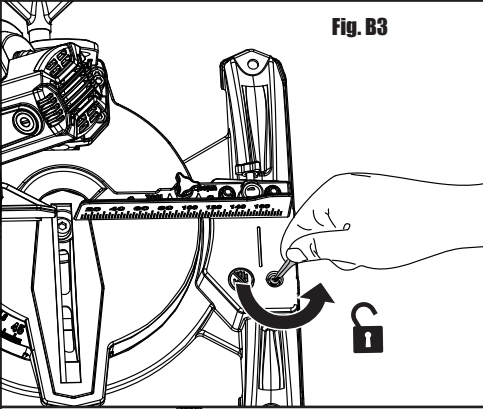

**Fig. B4**

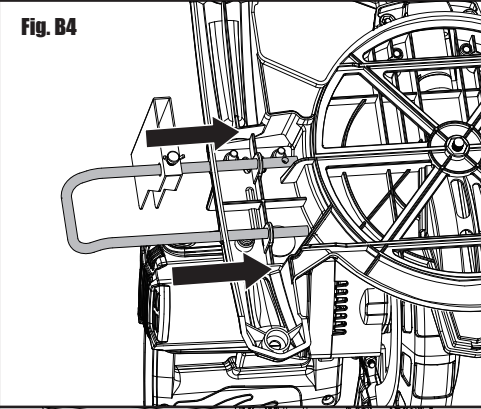

**Fig. B5**

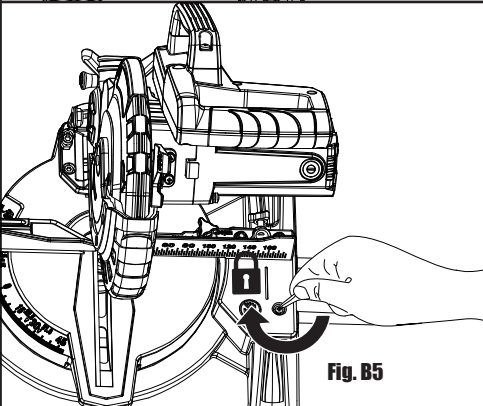

**Fig. B6**

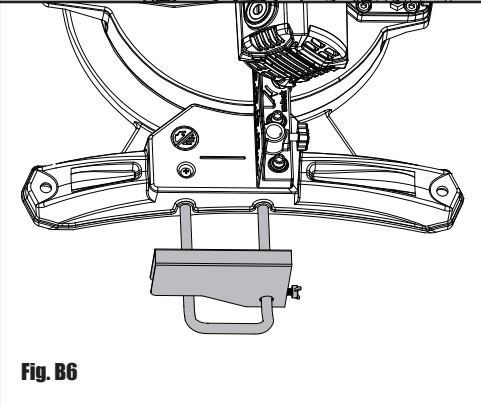

### 3. WORK CLAMP (SEE FIG. C)

When cutting workpieces, they should always be clamped with a work clamp. The work clamp can be fitted on either side of the saw and is fully adjustable to suit the size of the workpiece.

To install the work clamp, just insert it into the hole located at rear of the fence on either side of the base plate. Work clamp lock knob is used to secure the work clamp on the base plate. Adjustment knob (a) is used to adjust the height of the rail (c).

Adjustment knob (b) is used to lock the workpieces.

**NOTE:**

- Do not operate the saw without clamping the workpiece.
- Make sure that the work clamp securing screws are tightened.

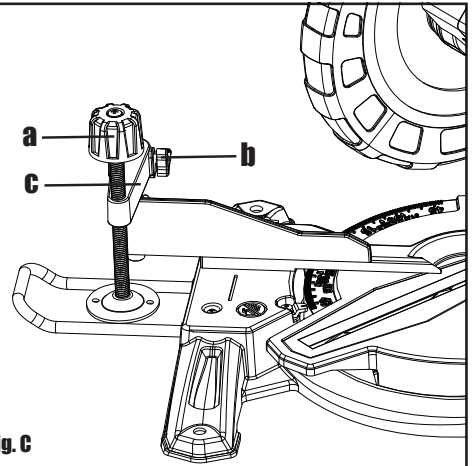

### 4. MOUNTING BOLT (SEE FIG. D)

Before use, the mitre saw can be fixed to a firm, level and stable supporting surface, such as a workbench.

Four mounting holes have been provided in the base plate for this purpose. Each of these four mounting holes should be securely bolted using appropriate machine bolt with suitable lock washer and hex nut (not supplied).

To mount the saw, proceed as follows:

- 1) Locate and mark where the saw is to be mounted.
- 2) Drill 4 holes through the surface.
- 3) Place the sliding mitre saw on the surface aligning holes in base with holes drilled in the surface.
- 4) Install and tighten the bolts, washers and hex nuts.

Carefully check the workbench after mounting the saw to make sure that no movement can occur during use.

If any tipping, sliding or walking is noted, secure the workbench to the floor before operating.

**NOTE:** The saw can be used without the need to mount. However, if you will be using the saw for a long period of time, we advise that it is mounted securely.

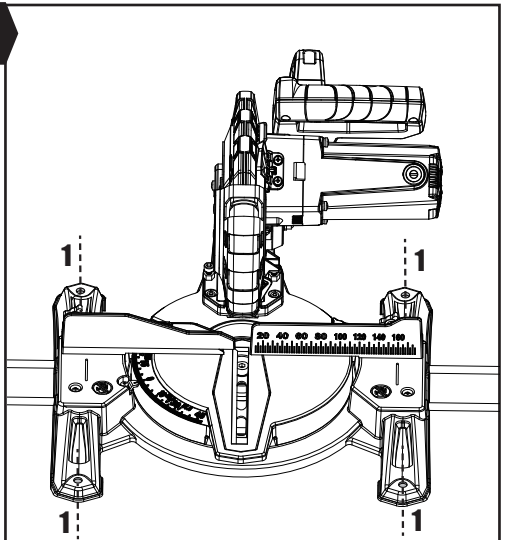

## BEFORE OPERATION

### 1. RELEASE KNOB (SEE FIG. E1-E3)

The release knob is provided for holding the saw head down while transporting or storing the mitre saw.

When boxed, during storage or transportation, ensure the saw head is locked in the down position. To release the head ready for operation, apply downward pressure on the operating handle, pull out the release knob and allow the head to rise to the upper position.

To lock the saw head down for transportation, push the lower blade lock lever outwards a little and lay down the saw head by pressing the operating handle downwards to its lowest position. Then push the release knob into original place to lock the saw head in the lowest position.

**NOTE:** The saw must never be used with the release knob locking the head down.

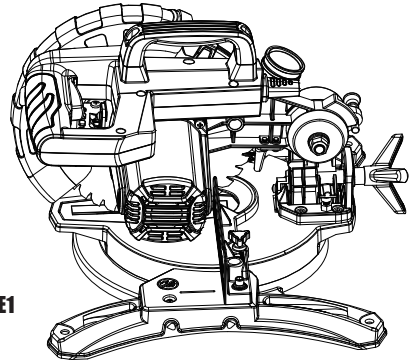

Fig. E1

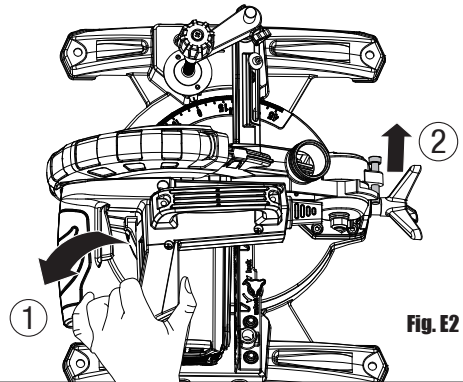

Fig. E2

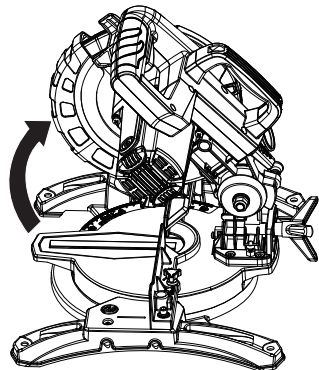

Fig. E3

## 2. MITRE TABLE LOCK (SEE FIG. F1, F2)

The mitre saw cuts from 0° to 45° only in the left side (the saw blade is facing to the operator).

To adjust the mitre angle, first loosen the mitre table lock knob by turning it anti-clockwise. Then hold the rotating mitre table handle and move the handle to the left in order to adjust the rotating mitre table to a desired angle. Align the pointer with the mitre angle scale marked on the table. After that, tighten mitre table lock knob by turning it clockwise to lock the mitre table in the required mitre angle.

The rotating mitre table features positive click stops at 0°, 15°, 22.5°, 30° and 45° for quick setting of common mitre angles.

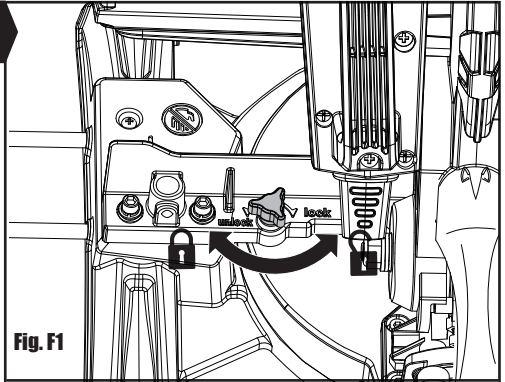

Fig. F1

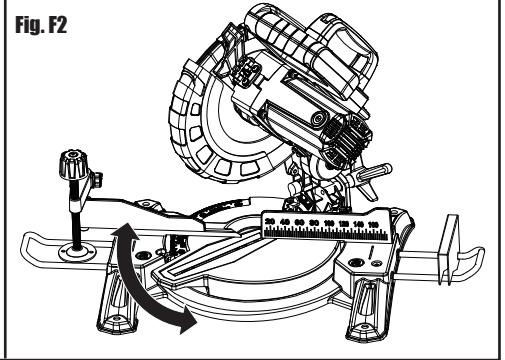

Fig. F2

## 3. BEVEL LOCK (SEE FIG. G1-G4)

The bevel lock is used to set the blade at the desired bevel angle. The mitre saw bevel cuts from 0° to 45° to the left (the saw blade is facing to the operator). To adjust the bevel angle, follow the steps below:

- 1) Loosen the locking bolt (d) using the M5 hex key provided located on the extended fence for bevel cutting. Pull the extended fence outwards to its farthest position. (See Fig. G1, G2) Tighten the locking bolt again to lock the fence.
- 2) Loosen the bevel lock knob by turning it anti-clockwise and move the saw head to the left (the saw blade is facing to the operator) to a desired bevel angle (between 0° and 45°). Tighten the bevel lock knob by turning it clockwise.

**NOTE:** Assemble the work clamp on the right side before adjusting into bevel cut mode.

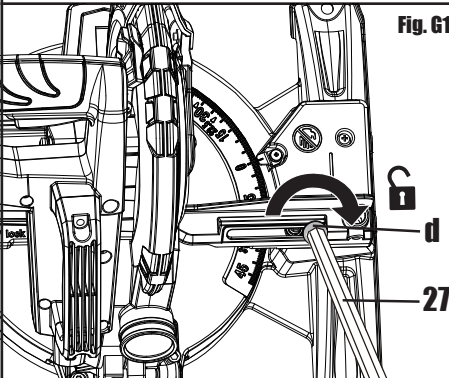

Fig. G1

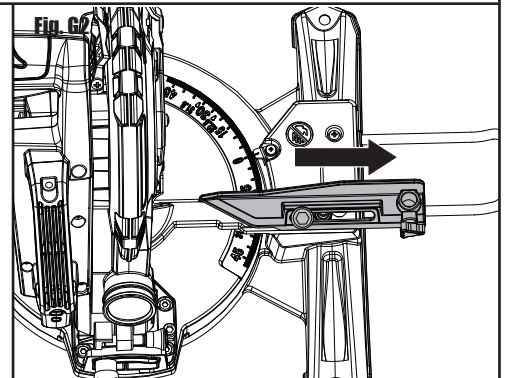
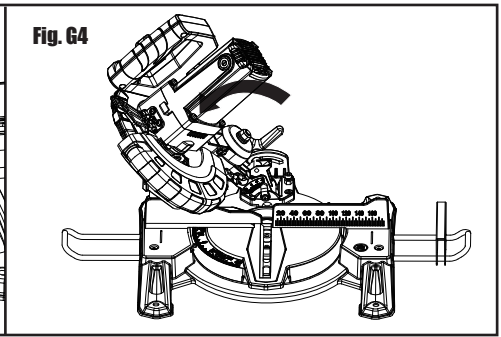
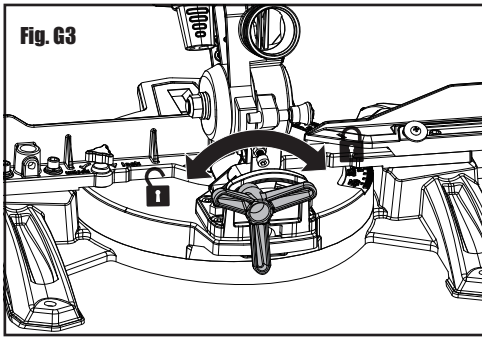
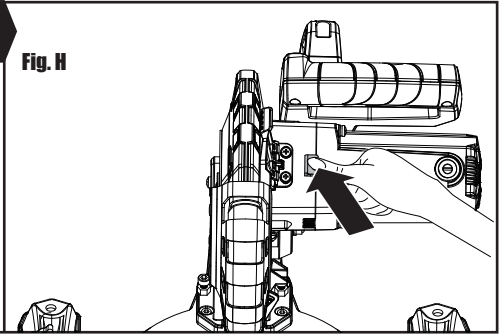

Fig. G2



#### 4. SPINDLE LOCK BUTTON (SEE FIG. H)

The spindle lock button prevents the blade in the saw from rotating. Depress and hold the spindle lock button while installing, changing, or removing the blade.



### OPERATION

#### 1. STARTING THE SAW (SEE FIG. I1, I2)

- 1) Push the lower blade lock lever outwards a little and hold it, so that the lock lever is far away from the upper fixed guard, and the lower rotating guard can rotate upwards. Then press down the saw head by holding the operating handle.
- 2) Squeeze the on/off switch to turn on the saw and allow the blade to reach full operational speed.
- 4) Gently but firmly lower the saw head and allow the blade to cut through the workpiece.
- 5) When the cut has been completed, hold the saw head in the down position and release the on/off switch.
- 6) Let the blade stop completely before allowing the saw head to rise to its upper position.
- 7) Remove your hand from the operating handle only when the saw head is raised, the blade is stationary and the lower blade guard is covering the blade.

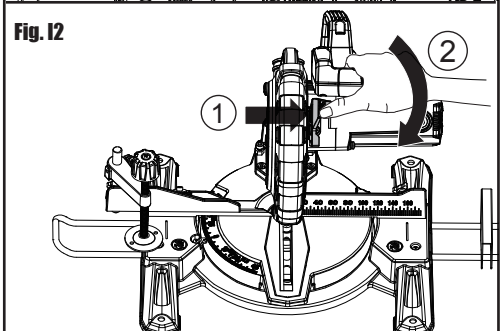
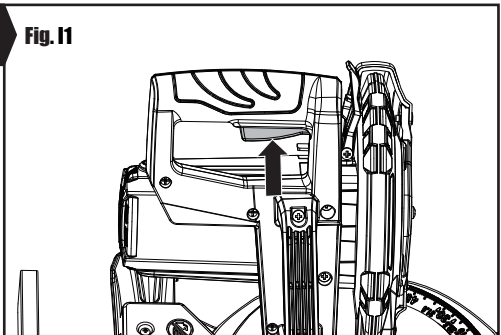

## 2. CROSS CUT (SEE FIG. J)

A crosscut is made by cutting across the grain of the workpiece. A 90° crosscut is made with the mitre table set at 0°.

- 1) Connect the machine to power outlet ensure that the mains cable is clear of the blade and base plate.
- 2) Position the material to be cut on the rotating mitre table with one edge securely against the fence, ensure it is firmly clamped with the work clamp so that it will not move during cutting.

**NOTE:** Ensure that the bevel lock knob is tightened before cutting.

- 3) Before turning on the saw, perform a dry run of the cutting operation just to make sure that no problems will occur when the cut is made.
- 4) Hold the operating handle firmly when squeezing the on/off switch. Allow several seconds for the blade to reach maximum speed.
- 5) Press and hold the on/off switch, slowly lower the saw head and blade into and through the work-piece. Continue to move the saw head down smoothly and make the cut exerting only gentle pressure on the downward stroke, letting the saw do the work.
- 6) Release the on/off switch. Allow the saw blade to stop rotating BEFORE raising the blade out of the work-piece. Wait until the blade stops before removing the workpiece.

## 3. MITRE CUT (SEE FIG. K)

A mitre cut is made at 0° bevel and any mitre angle in the range from 0° to 45° left (the saw blade is facing to the operator).

To adjust the mitre angle, refer to MITRE TABLE LOCK section in the BEFORE OPERATION section.

After setting the required mitre angle, follow the procedures of cross cut.

## 4. BEVEL CUT (SEE FIG. L)

A bevel cut is made at 0° mitre and any bevel angle in the range of 0° to 45° left (the saw blade is facing to the operator). The saw can be moved from the normal 0° perpendicular position to an angled position down to 45° from the horizontal, on the left only.

The bevel lock is used to set the blade at the desired bevel angle. To adjust the bevel angle, refer to BEVEL LOCK section in the BEFORE OPERATION section.

After setting the required bevel angle, follow the procedures of cross cut.

## 5. COMPOUND CUT (SEE FIG. M)

A compound mitre cut is a cut made using a mitre angle and a bevel angle at the same time. This type of cut is used for mouldings, picture frames, and boxes with sloping sides. Always make a test cut on a piece of scrap wood before cutting into the good material.

Set the mitre angle and bevel angle refer to MITRE TABLE LOCK section and BEVEL LOCK section in the BEFORE OPERATION section.

After setting the required mitre and bevel angle, follow the procedures of cross cut.



**Fig. J**

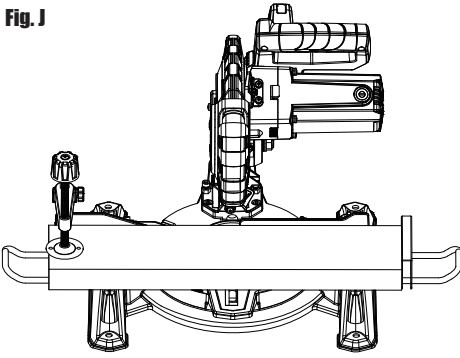

**Fig. K**

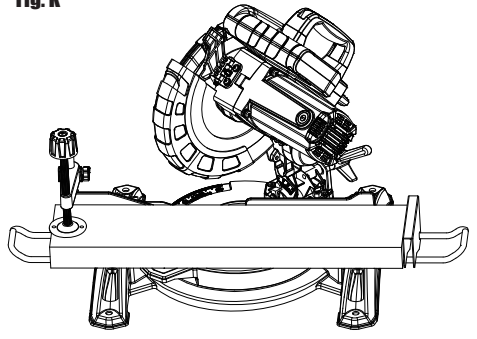

**Fig. L**

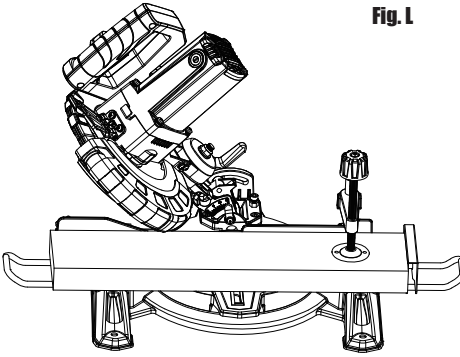

**Fig. M**

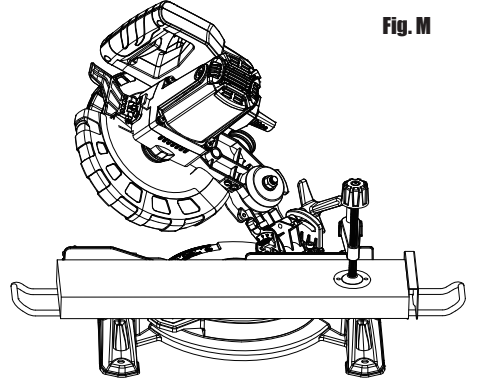

# MAINTENANCE

Remove the plug from the socket before carrying out any adjustment, servicing or maintenance.

There are no user serviceable parts in your power tool. Never use water or chemical cleaners to clean your power tool. Wipe clean with a dry cloth. Always store your power tool in a dry place. Keep the motor ventilation slots clean. Keep all working controls free of dust. Occasionally you may see sparks through the ventilation slots. This is normal and will not damage your power tool. If the supply cord is damaged, it must be replaced by the manufacturer, its service agent or similarly qualified persons in order to avoid a hazard.

## 1. PRECISION SETTING OF ANGLES(SEE FIG. N1-N4)

While the machine has been factory set, it is advisable that the  $0^\circ$  setting of the rotary table and the  $90^\circ$  perpendicular setting of the tilt be checked, as these positions may have moved in transit.

To confirm the  $0^\circ$  rotating mitre table setting, set the rotating mitre table at  $0^\circ$  and tighten the mitre table lock latch. Check that the angle between the straight guide and the blade is  $90^\circ$  using a tri-square (e) (not supplied) as shown in Fig. N1. If the angle requires adjustment, loosen the locking bolts (f) for straight guide, and align the fence against the tri-square.

Re-tighten the locking bolts (f) for straight guide.

Similarly, check that the angle of the blade to the face of the rotary table is  $90^\circ$ . If necessary, adjust the tilt angle of the saw head at the  $90^\circ$  position: loosen the bevel lock lever and adjust the  $0^\circ$  bevel adjustment screw (g) to bring the saw blade into alignment with the square.

Loosen the head screw (h) holding the pointer of the bevel scale and adjust the position of the pointer so that it accurately indicates zero on the scale. Retighten the head screw (h). Retighten the bevel lock lever and the  $0^\circ$  bevel adjustment screw (g).

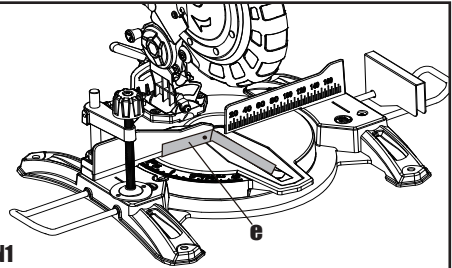

Fig. N1

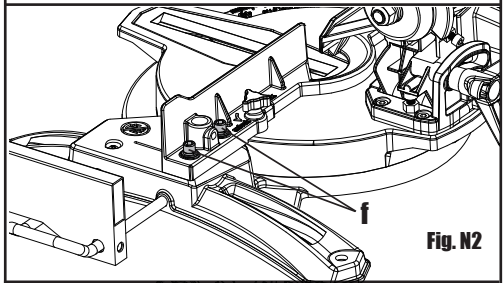

Fig. N2

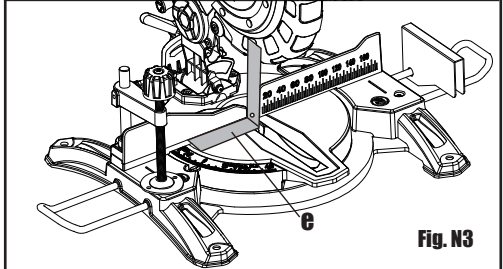

Fig. N3

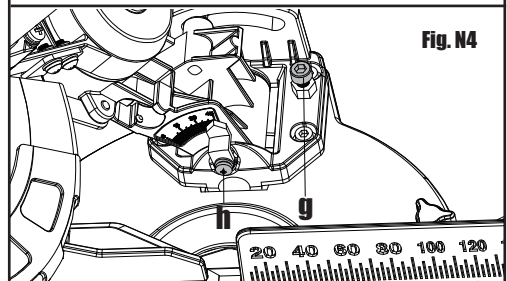

Fig. N4

## 2. CHANGING THE SAW BLADE (SEE FIG. 01-04)

**WARNING:** To prevent personal injury, always disconnect the plug from power source before assembling parts, making adjustments or changing blades.

- 1) Unplug the saw from the power supply.
- 2) Release and raise the saw head to its fully raised position. Caution, the lower blade guide is spring loaded.
- 3) Loosen and remove the screw (i) from the lower left of the upper fixed guard as shown in Fig. 01.
- 4) Push the lower blade lock lever outwards a little and hold it, then rotate the lower rotating guard together with the blade bolt cover anti-clockwise until the blade bolt appears.
- 5) Depress the spindle lock button and rotate the saw blade with an anti-clockwise direction until the spindle lock button engages and the saw blade cannot rotate.
- 6) Use the M8 hex key for blade provided to loosen and remove the blade bolt by turning it clockwise. Remove the outer flange, and the saw blade. DO NOT remove the inner flange.
- 7) Wipe a drop of oil onto the inner flange and the outer flange where they come in contact with the blade.

**WARNING:** If the inner flange has been removed, reposition it BEFORE placing blade on the spindle. Failure to do so could cause an accident because the blade will not tighten properly.

**CAUTION:** ALWAYS install the blade with the blade teeth and the arrow printed on the side of the blade pointing down at the front of the saw. The direction of blade rotation is also stamped with an arrow on the lower blade guard.

**WARNING:** To prevent damage to the spindle lock, always allow the motor to come to a complete stop before engaging the spindle lock. Always make sure the spindle lock is disengaged before reconnecting saw to the power source.

- 8) Fit the new blade onto the spindle taking care that the inner flange sits behind the saw blade.
- 9) Reposition the outer flange.
- 10) Depress the spindle lock button and reposition the blade bolt.
- 11) Use the supplied M8 hex key to tighten the blade bolt securely (tighten in an anti-clockwise direction).
- 12) Re-tighten the screw (i).
- 13) Check that the blade guard operates correctly and covers the blade as the operating handle is lowered.
- 14) Connect the saw to the power supply and run the blade to make certain that it is operating correctly.

Fig.01

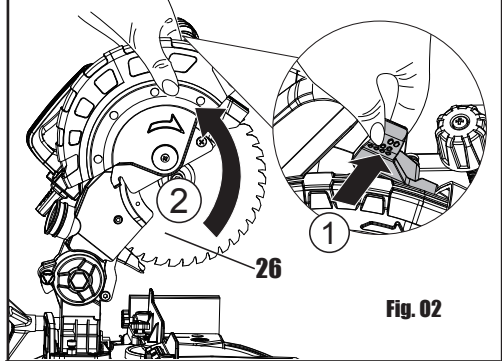
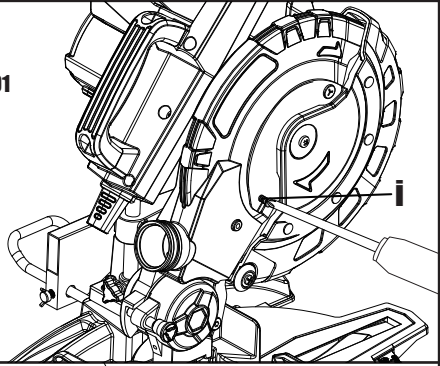

Fig. 02

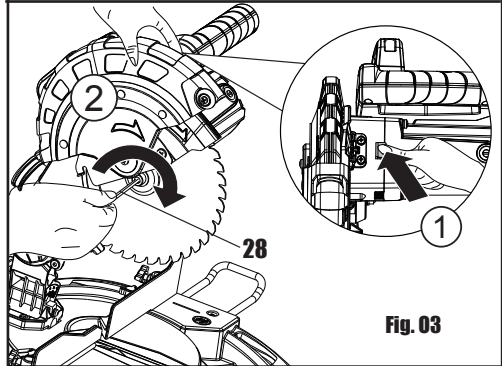

Fig. 03

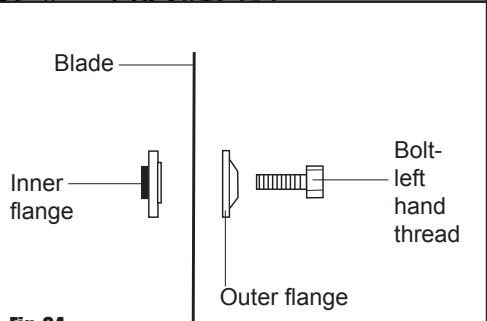

Fig. 04

# ENVIRONMENTAL PROTECTION



Waste electrical products should not be disposed of with household waste. Please recycle where facilities exist. Check with your Local Authority or retailer for recycling advice.

# PLUG REPLACEMENT (ONLY FOR REWIRABLE PLUG OF UK & IRELAND)

If you need to replace the fitted plug then follow the instructions below.

### IMPORTANT

The wires in the mains lead are colored in accordance with the following code:

Blue = Neutral

Brown = Live

As the colors of the wires in the mains lead of this appliance may not correspond with the colored markings identifying the terminals in your plug, proceed as follows. The wire which is colored blue must be connected to the terminal which is marked with N. The wire which is colored brown must be connected to the terminal which is marked with L.



### WARNING:

Never connect live or neutral wires to the earth terminal of the plug. Only fit an approved 13A BS1363/A plug and the correct rated fuse.

Note: If a moulded plug is fitted and has to be removed take great care in disposing of the plug and severed cable, it must be destroyed to prevent engaging into a socket.

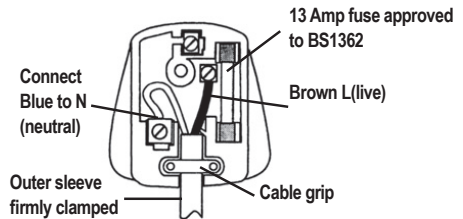

# DECLARATION OF CONFORMITY

We,  
**Wickes Building Supplies Limited**

**Declare that this product: COMPOUND MITRE SAW**  
*Description and SKU code: 223748*

**Complies with the following Directives and Regulations:**  
2006/42/EC, Machinery Directive  
2014/30/EU, Electromagnetic Compatibility Directive  
2011/65/EU & (EU)2015/863 (RoHS), Restriction of Hazardous Substances Directive

**and conforms to the following standards:**

*Standards specific to this product:*

**EN 62841-1**  
**EN 62841-3-9**  
**EN 55014-1**  
**EN 55014-2**  
**EN 61000-3-2**  
**EN 61000-3-3**



28<sup>th</sup> January, 2021  
Philip Ansell  
Category Technical Manager  
Wickes  
Vision House  
19 Colonial Way  
Watford  
WD24 4JL"





**Customer Helpline 0345 2005409**