

Wickes

RECIPROCATING SAW

850W



PSR8501.1
223749

CONTENTS

GENERAL POWER TOOL SAFETY WARNINGS 3

COMPONENT LIST 5

ACCESSORIES 5

SYMBOLS 6

TECHNICAL DATA 6

NOISE INFORMATION 6

OPERATING INSTRUCTIONS 8

WORK HINTS FOR YOUR RECIPROCATING SAW 12

MAINTENANCE 12

ENVIRONMENTAL PROTECTION 12

PLUG REPLACEMENT (ONLY FOR REWIRABLE PLUG OF UK & IRELAND) 13

DECLARATION OF CONFORMITY 14

ORIGINAL INSTRUCTION

GENERAL POWER TOOL SAFETY WARNINGS

 **WARNING!** Read all safety warnings, instructions, illustrations and specifications provided with this power tool. Failure to follow all instructions listed below may result in electric shock, fire and/or serious injury.

SAVE ALL WARNINGS AND INSTRUCTIONS FOR FUTURE REFERENCE.

The term "power tool" in the warnings refers to your mains-operated (corded) power tool or battery-operated (cordless) power tool.

1. WORK AREA SAFETY

- a) **Keep work area clean and well lit.** Cluttered or dark areas invite accidents.
- b) **Do not operate power tools in explosive atmospheres, such as in the presence of flammable liquids, gases or dust.** Power tools create sparks which may ignite the dust or fumes.
- c) **Keep children and bystanders away while operating a power tool.** Distractions can cause you to lose control.

2. ELECTRICAL SAFETY

- a) **Power tool plugs must match the outlet. Never modify the plug in any way. Do not use any adapter plugs with earthed (grounded) power tools.** Unmodified plugs and matching outlets will reduce risk of electric shock.
- b) **Avoid body contact with earthed or grounded surfaces, such as pipes, radiators, ranges and refrigerators.** There is an increased risk of electric shock if your body is earthed or grounded.
- c) **Do not expose power tools to rain or wet conditions.** Water entering a power tool will increase the risk of electric shock.
- d) **Do not abuse the cord. Never use the cord for carrying, pulling or unplugging the power tool. Keep cord away from heat, oil, sharp edges or moving parts.** Damaged or entangled cords increase the risk of electric shock.
- e) **When operating a power tool outdoors, use an extension cord suitable for outdoor use.** Use of a cord suitable for outdoor use reduces the risk of electric shock.
- f) **If operating a power tool in a damp location is unavoidable, use a residual current device (RCD) protected supply.** Use of an RCD reduces the risk of electric shock.

3. PERSONAL SAFETY

- a) **Stay alert, watch what you are doing and use common sense when operating a power tool. Do not use a power tool while you are tired or under the influence of drugs, alcohol or medication.** A moment of inattention while operating power tools may result in serious personal injury.
- b) **Use personal protective equipment. Always wear eye protection.** Protective equipment such as dust mask, non-skid safety shoes, hard hat, or hearing protection used for appropriate conditions will reduce personal injuries.
- c) **Prevent unintentional starting. Ensure the switch is in the off-position before connecting to power source and/or battery pack, picking up or carrying the tool.** Carrying power tools with your finger on the switch or energising power tools that have the switch on invites accidents.
- d) **Remove any adjusting key or wrench before turning the power tool on.** A wrench or a key left attached to a rotating part of the power tool may result in personal injury.
- e) **Do not overreach. Keep proper footing and balance at all times.** This enables better control of the power tool in unexpected situations.
- f) **Dress properly. Do not wear loose clothing or jewellery. Keep your hair and clothing away from moving parts.** Loose clothes, jewellery or long hair can be caught in moving parts.
- g) **If devices are provided for the connection of dust extraction and collection facilities, ensure these are connected and properly used.** Use of dust collection can reduce dust-related hazards.
- h) **Do not let familiarity gained from frequent use of tools allow you to become complacent and ignore tool safety principles.** A careless action can cause severe injury within a fraction of a second.

4. POWER TOOL USE AND CARE

- a) **Do not force the power tool. Use the correct power tool for your application.** The correct power tool will do the job better and safer at the rate for which it was designed.
- b) **Do not use the power tool if the switch does not turn it on and off.** Any power tool that cannot be controlled with the switch is dangerous and must be repaired.
- c) **Disconnect the plug from the power source and/or remove the battery pack, if detachable, from**

GENERAL POWER TOOL SAFETY WARNINGS

- the power tool before making any adjustments, changing accessories, or storing power tools.** *Such preventive safety measures reduce the risk of starting the power tool accidentally.*
- d) Store idle power tools out of the reach of children and do not allow persons unfamiliar with the power tool or these instructions to operate the power tool.** *Power tools are dangerous in the hands of untrained users.*
 - e) Maintain power tools and accessories. Check for misalignment or binding of moving parts, breakage of parts and any other condition that may affect the power tool's operation. If damaged, have the power tool repaired before use.** *Many accidents are caused by poorly maintained power tools.*
 - f) Keep cutting tools sharp and clean.** *Properly maintained cutting tools with sharp cutting edges are less likely to bind and are easier to control.*
 - g) Use the power tool, accessories and tool bits etc. in accordance with these instructions, taking into account the working conditions and the work to be performed.** *Use of the power tool for operations different from those intended could result in a hazardous situation.*
 - h) Keep handles and grasping surfaces dry, clean and free from oil and grease.** *Slippery handles and grasping surfaces do not allow for safe handling and control of the tool in unexpected situations.*
- 5. SERVICE**
- a) Have your power tool serviced by a qualified repair person using only identical replacement parts.** *This will ensure that the safety of the power tool is maintained.*

RECIPROCATING SAW SAFETY WARNINGS

- 1. Hold reciprocating saw by insulated gripping surfaces, when performing an operation where the cutting accessory may contact hidden wiring or its own cord.** *Cutting accessory contacting a "live" wire may make exposed metal parts of the power tool "live" and could give the operator an electric shock.*
- 2. Use clamps or another practical way to secure and support the workpiece to a stable platform.** *Holding the workpiece by hand or against your body leaves it unstable and may lead to loss of control.*

COMPONENT LIST

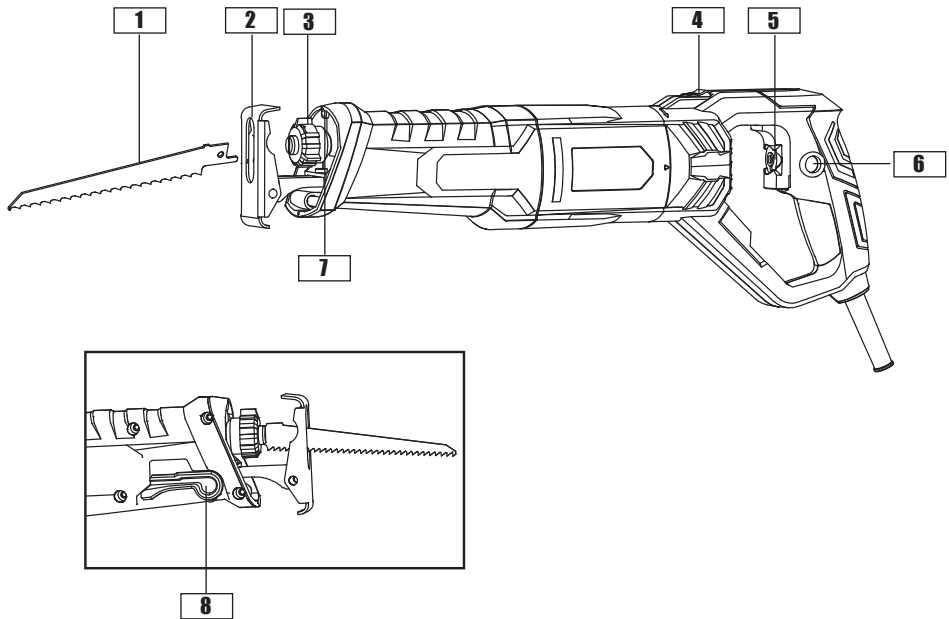

- | | | | |
|----------|-------------------------------------|----------|---|
| 1 | Blade | 5 | On/off switch with variable speed control |
| 2 | Pivoting blade foot | 6 | Lock on button |
| 3 | Tool-free blade clamp ring | 7 | Light |
| 4 | Rear handle rotation locking button | 8 | Locking lever for pivoting blade foot |

ACCESSORIES

- | | |
|-----------------|---|
| Blade for metal | 1 |
| Blade for wood | 1 |

We recommend that you purchase your accessories from the same store that sold you the tool. Use good quality accessories marked with a well-known brand name. Choose the type according to the work you intend to undertake. Refer to the accessory packaging for further details. Store personnel can assist you and offer advice.

SYMBOLS



To reduce the risk of injury, read all of this instruction manual



Wear dust mask



Warning



Double insulated



Wear ear protection



Waste electrical products must not be disposed of with household waste. Please recycle where facilities exist. Check with your local authorities or retailer for recycling advice.



Wear eye protection

TECHNICAL DATA

Rated Voltage		230-240V~50Hz
Rated Power		850W
Rated No-load speed		0-2800 /min
Stroke length		28mm
Charger Protection class		□/II
Cutting capacity max.	Steel	8mm
	Wood	160mm
Machine weight		2.5Kg

NOISE INFORMATION

A weighted sound pressure	L_{pA}	80.57dB(A)
A weighted sound power	L_{wA}	91.57dB(A)
K_{pA} & K_{wA}		5.0dB(A)
Wear ear protection.		

VIBRATION INFORMATION

Vibration total values (triax vector sum) determined according to EN 62841:	
Cutting boards	Vibration emission value $a_{h,B} = 7.675\text{m/s}^2$
	Uncertainty $K = 1.5\text{ m/s}^2$
Cutting wooden beams	Vibration emission value $a_{h,WB} = 8.060\text{m/s}^2$
	Uncertainty $K = 1.5\text{ m/s}^2$

The declared vibration total value and the declared noise emission value have been measured in accordance with a standard test method and may be used for comparing one tool with another.

The declared vibration total value and the declared noise emission value may also be used in a preliminary assessment of exposure.

WARNING! The vibration and noise emissions during actual use of the power tool can differ from the declared value depending on the ways in which the tool is used especially what kind of workpiece is processed dependant on the following examples and other variations on how the tool is used:

How the tool is used and the materials being cut or drilled.

The tool being in good condition and well maintained.

The use of the correct accessory for the tool and ensuring it is sharp and in good condition.

The tightness of the grip on the handles and if any anti vibration and noise accessories are used.

And the tool is being used as intended by its design and these instructions.

This tool may cause hand-arm vibration syndrome if its use is not adequately managed.

WARNING! To be accurate, an estimation of exposure level in the actual conditions of use should also take account of all parts of the operating cycle such as the times when the tool is switched off and when it is running idle but not actually doing the job. This may significantly reduce the exposure level over the total working period, helping to minimize your vibration exposure risk.

Always use sharp chisels, drills and blades.

Maintain this tool in accordance with these instructions and keep well lubricated (where appropriate).

If the tool is to be used regularly then invest in anti vibration and noise accessories.

Plan your work schedule to spread any high vibration tool use across a number of days.

OPERATING INSTRUCTIONS



NOTE: Before using the tool, read the instruction book carefully.

Intended Use

The machine is intended for sawing wood, plastic, metal and building materials while resting firmly on the workpiece. It is suitable for straight and curved cuts.

1. REPLACING / INSERTING THE SAW BLADE (See Fig. A1,A2)

WARNING! Remove the plug from the socket before carrying out any adjustment, servicing or maintenance.

When fitting the saw blade, wear protective gloves. Danger of injury when touching the saw blade. When changing the saw blade, take care that the saw blade holder is free of material residue.

SELECTING A SAW BLADE

Use only saw blades with single-nose shank. The saw blade should not be longer than required for the intended cut. Use a thin saw blade for narrow curve cuts.

INSERTING A SAW BLADE (SEE FIG. A1)

Rotate the tool-free blade clamp ring (3) anti-clockwise and hold. Insert the blade into the blade clamp and release. Ensure that the blade is locked securely in place.

WARNING! Check the blade is retained securely. A loose saw blade can fall out and lead to injuries.

For certain work, the saw blade (1) can also be turned through 180° (with the teeth pointed upwards) and reinserted again.

REMOVING A SAW BLADE (SEE FIG. A2)

Rotate the tool-free blade clamp ring (3) anti-clockwise and hold. Pull the blade out and release the clamp ring.

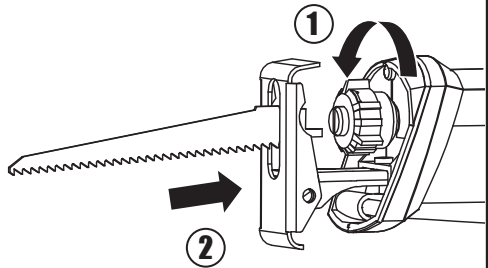

Fig. A1

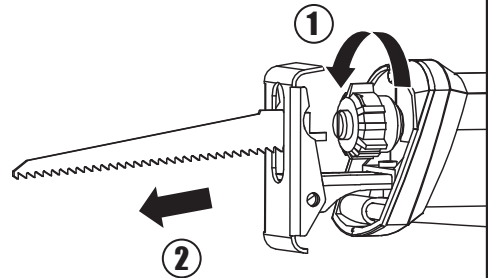

Fig. A2

OPERATION

1. PIVOTING BLADE FOOT (See Fig. B)

Due to its movability, the adjustable pivoting blade foot (2) adapts to the required angular position of the surface. It must be held firmly against the material being cut to reduce saw vibration, blade jumping and blade breakage.

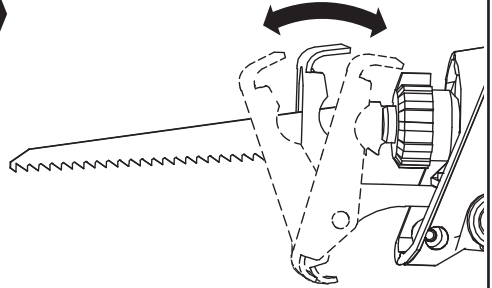

Fig. B

2. ADJUST THE DEPTH OF CUT (See Fig. C1, C2)

If you need to reduce the cutting capacity of your tool (depth of cut), the pivoting foot plate (2) may be adjusted as follows. Rotate the lock lever for pivoting blade foot (8) on the underside of the front housing forwards. Slide the pivoting blade foot (2) to the required position. Rotate the grip back and check that the blade foot (2) is firmly latched.

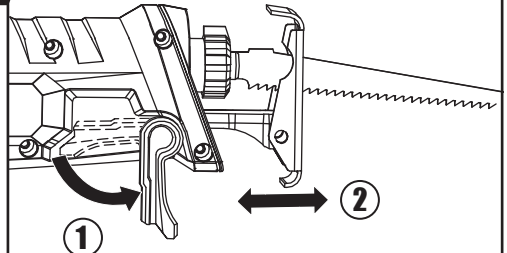

Fig. C1

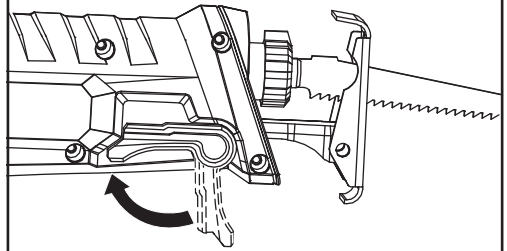

Fig. C2

3. ADJUST THE REAR HANDLE ANGLE (See Fig. D1, D2)

Press the rear handle rotation locking button (4), rotate the rear handle clockwise or anticlockwise according to the required application.

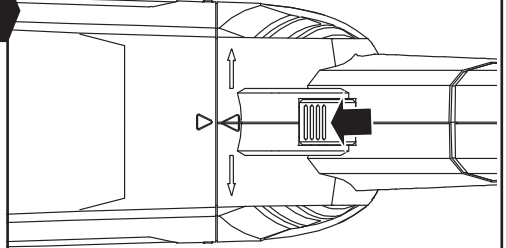

Fig. D1

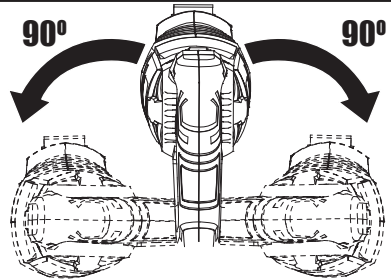

Fig. D2

4. ON/OFF SWITCH WITH VARIABLE SPEED CONTROL (See Fig. E)

Depress the On/Off Switch (5) to start and release it to stop your tool.
Depress the On/Off Switch (5) then the lock on button (6). Your tool is now locked on for continuous use. To switch off your tool just depress and release the on/off switch (5).

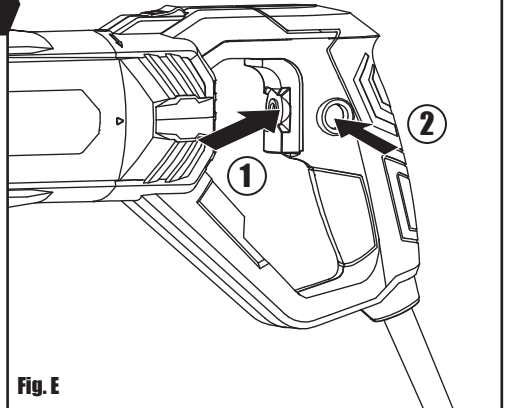

Fig. E

5. CONTROLLING THE STROKE RATE (See Fig. F)

For sawing appropriately to the material a suitable stroke rate can be set with the variable speed control (5). To increase the speed, rotate the variable speed control clockwise. To reduce turn anticlockwise.

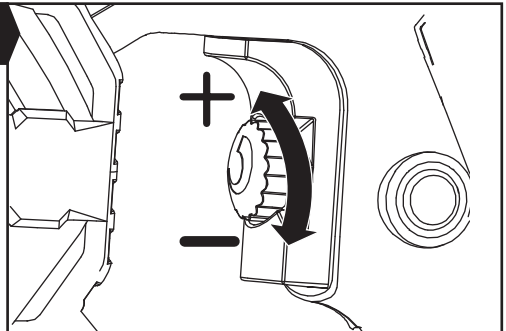

Fig. F

6. CUTTING INSTRUCTION (See Fig. G)

PLUNGE CUTTING (See Fig. G1,G2)

WARNING! The plunge cutting procedure is only suitable for treating soft materials such as wood, plaster board or similar! Do not attempt a plunge cut on hard materials such as metal!

Use only short saw blades for plunge cutting. Place the machine with the edge of the blade foot (2) onto the workpiece and switch on. For power tools with stroke speed control, set the maximum stroke speed. Press the power tool firmly against the workpiece and allow the saw blade to slowly plunge into the workpiece.

As soon as the blade foot (2) fully lays on the surface of the workpiece, continue sawing alongside the desired cutting line. For certain work, the saw blade (1) can also be inserted turned through by 180° and the sabre saw can be guided accordingly in a reversed manner.

FLUSH CUTTING (See Fig. G3,G4)

WARNING! Pay attention that the saw blade always extends beyond the diameter of the material being worked. There is danger of kickback. It is possible to make cuts extremely close to floors, walls and other difficult areas. Insert the blade shank into the blade clamp with the blade teeth facing up (opposite to normal working position). This will make cuts closer to the work surface. Using special flexible blades insert the blade into the blade clamp with the blade teeth facing down (normal working position). It will allow flush pipe cutting.

WOOD CUTTING

For easier control use low speed to start cutting, then increase to the correct speed.

METAL CUTTING

This saw has different metal cutting capacities depending upon the type of blade being used and metal being cut. Use a finer blade for ferrous metals and a coarse blade for non-ferrous metals.

When cutting thin gauge sheet metals, **ALWAYS** clamp wood on both sides of the sheet. This will give you a clean cut without excess vibration or tearing of the metal. **DO NOT** force the cutting blade. Forcing the blade will reduce blade life and cause the blade to break.

NOTE: We recommend that you spread a thin film of oil or other coolant along the line of cut ahead of the saw. This will allow easier operation and help extend blade life. When cutting aluminum, use paraffin.

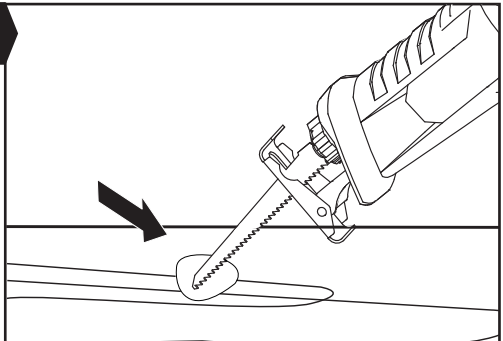

Fig. G1

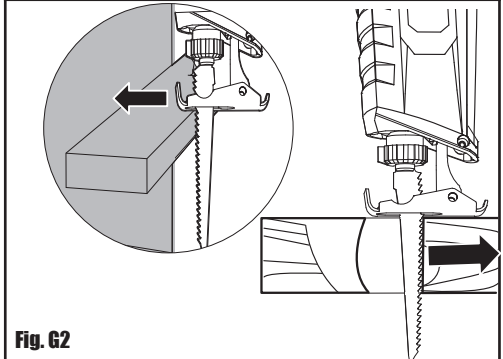

Fig. G2

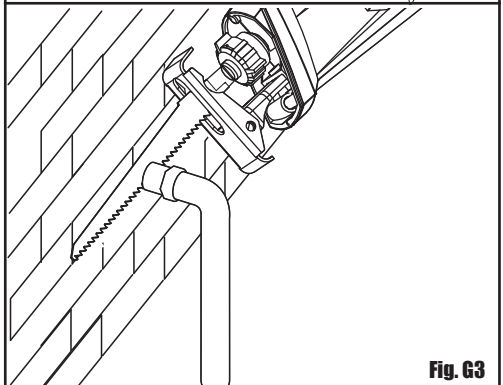

Fig. G3

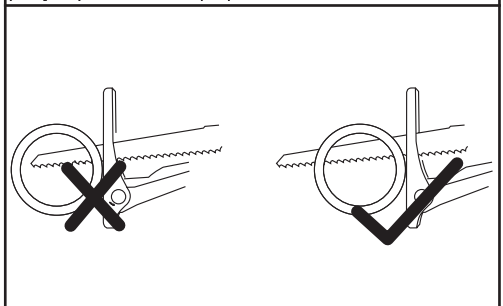

Fig. G4

WORK HINTS FOR YOUR RECIPROCATING SAW

If your power tool becomes too hot, set the speed to maximum and run a no load for 2-3 minutes to cool the motor. Always ensure the work-piece is firmly held or clamped to prevent movement. The blade guard must be held firmly against the material being cut to reduce saw vibration, blade jumping and blade breakage.

MAINTENANCE



WARNING! Remove the plug from the socket before carrying out any adjustment, servicing or maintenance. There are no user serviceable parts in your power tool. Never use water or chemical cleaners to clean your power tool. Wipe clean with a dry cloth. Always store your power tool in a dry place. Keep the motor ventilation slots clean. Keep all working controls free of dust. Occasionally you may see sparks through the ventilation slots. This is normal and will not damage your power tool. If the supply cord is damaged, it must be replaced by the manufacturer, its service agent or similarly qualified persons in order to avoid a hazard.

ENVIRONMENTAL PROTECTION



Waste electrical products must not be disposed of with household waste. Please recycle where facilities exist. Check with your local authorities or retailer for recycling advice.

PLUG REPLACEMENT (ONLY FOR REWIRABLE PLUG OF UK & IRELAND)

If you need to replace the fitted plug then follow the instructions below.

IMPORTANT

The wires in the mains lead are colored in accordance with the following code:

Blue = Neutral

Brown = Live

As the colors of the wires in the mains lead of this appliance may not correspond with the colored markings identifying the terminals in your plug, proceed as follows. The wire which is colored blue must be connected to the terminal which is marked with N. The wire which is colored brown must be connected to the terminal which is marked with L.



WARNING:

Never connect live or neutral wires to the earth terminal of the plug. Only fit an approved 13A BS1363/A plug and the correct rated fuse.

Note: If a moulded plug is fitted and has to be removed take great care in disposing of the plug and severed cable, it must be destroyed to prevent engaging into a socket.

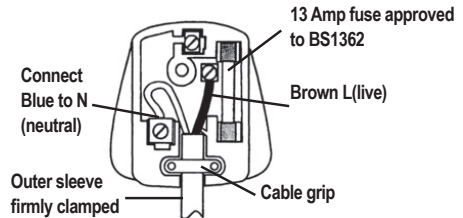

DECLARATION OF CONFORMITY

We,
Wickes Building Supplies Limited

Declare that this product: CORDLESS RECIPROCATING SAW
Description and SKU code: 223749

Complies with the following Directives and Regulations:
2006/42/EC, Machinery Directive
2014/30/EU, Electromagnetic Compatibility Directive
2011/65/EU & (EU)2015/863 (RoHS), Restriction of Hazardous Substances Directive

and conforms to the following standards:
Standards specific to this product:

EN 62841-1
EN 62841-2-11
EN 55014-1
EN 55014-2
EN 61000-3-2
EN 61000-3-3

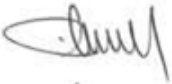

28th January, 2021
Philip Ansell
Category Technical Manager
Wickes
Vision House
19 Colonial Way
Watford
WD24 4JL”

Customer Helpline 0345 2005409