

# Wickes

## ROTARY HAMMER

**1500W**



**PDH32DS.2**  
**223724**

# CONTENTS

**GENERAL POWER TOOL SAFETY WARNINGS 3**

**COMPONENT LIST 5**

**ACCESSORIES 6**

**SYMBOLS 6**

**TECHNICAL DATA 6**

**NOISE INFORMATION 7**

**OPERATING INSTRUCTIONS 8**

**WORKING HINTS FOR YOUR ROTARY HAMMER DRILL 12**

**MAINTENANCE 12**

**TROUBLESHOOTING 12**

**ENVIRONMENTAL PROTECTION 12**

**PLUG REPLACEMENT (ONLY FOR REWIRABLE PLUG OF UK & IRELAND) 13**

**DECLARATION OF CONFORMITY 14**

# GENERAL POWER TOOL SAFETY WARNINGS

**⚠ WARNING!** Read all safety warnings and all instructions. Failure to follow the warnings and instructions may result in electric shock, fire and/or serious injury.

CAUTION: This machine is capable of generating considerable torque and misuse can result in significant injury.

## SAVE ALL WARNINGS AND INSTRUCTIONS FOR FUTURE REFERENCE.

The term "power tool" in the warnings refers to your mains-operated (corded) power tool or battery-operated (cordless) power tool.

### 1. WORK AREA SAFETY

- a) **Keep work area clean and well lit.** Cluttered or dark areas invite accidents.
- b) **Do not operate power tools in explosive atmospheres, such as in the presence of flammable liquids, gases or dust.** Power tools create sparks which may ignite the dust or fumes.
- c) **Keep children and bystanders away while operating a power tool.** Distractions can cause you to lose control.

### 2. ELECTRICAL SAFETY

- a) **Power tool plugs must match the outlet. Never modify the plug in any way. Do not use any adapter plugs with earthed (grounded) power tools.** Unmodified plugs and matching outlets will reduce risk of electric shock.
- b) **Avoid body contact with earthed or grounded surfaces, such as pipes, radiators, ranges and refrigerators.** There is an increased risk of electric shock if your body is earthed or grounded.
- c) **Do not expose power tools to rain or wet conditions.** Water entering a power tool will increase the risk of electric shock.
- d) **Do not abuse the cord. Never use the cord for carrying, pulling or unplugging the power tool. Keep cord away from heat, oil, sharp edges or moving parts. Damaged or entangled cords increase the risk of electric shock.**
- e) **When operating a power tool outdoors, use an extension cord suitable for outdoor use.** Use of a cord suitable for outdoor use reduces the risk of electric shock.
- f) **If operating a power tool in a damp location is unavoidable, use a residual current device (RCD) protected supply.** Use of an RCD reduces the risk of electric shock.

### 3. PERSONAL SAFETY

- a) **Stay alert, watch what you are doing and use common sense when operating a power tool. Do not use a power tool while you are tired or under the influence of drugs, alcohol or medication.** A moment of inattention while operating power tools may result in serious personal

injury.

- b) **Use personal protective equipment. Always wear eye protection.** Protective equipment such as dust mask, non-skid safety shoes, hard hat, or hearing protection used for appropriate conditions will reduce personal injuries.
  - c) **Prevent unintentional starting. Ensure the switch is in the off-position before connecting to power source and/or battery pack, picking up or carrying the tool.** Carrying power tools with your finger on the switch or energising power tools that have the switch on invites accidents.
  - d) **Remove any adjusting key or wrench before turning the power tool on.** A wrench or a key left attached to a rotating part of the power tool may result in personal injury.
  - e) **Do not overreach. Keep proper footing and balance at all times.** This enables better control of the power tool in unexpected situations.
  - f) **Dress properly. Do not wear loose clothing or jewellery. Keep your hair, clothing and gloves away from moving parts.** Loose clothes, jewellery or long hair can be caught in moving parts.
  - g) **If devices are provided for the connection of dust extraction and collection facilities, ensure these are connected and properly used.** Use of dust collection can reduce dust-related hazards.
- ### 4. POWER TOOL USE AND CARE
- a) **Do not force the power tool. Use the correct power tool for your application.** The correct power tool will do the job better and safer at the rate for which it was designed.
  - b) **Do not use the power tool if the switch does not turn it on and off.** Any power tool that cannot be controlled with the switch is dangerous and must be repaired.
  - c) **Disconnect the plug from the power source and/or the battery pack from the power tool before making any adjustments, changing accessories, or storing power tools.** Such preventive safety measures reduce the risk of starting the power tool accidentally.
  - d) **Store idle power tools out of the reach of children and do not allow persons unfamiliar with the power tool or these instructions to operate the power tool.** Power tools are dangerous in the hands of untrained users.
  - e) **Maintain power tools. Check for misalignment or binding of moving parts, breakage of parts and any other condition that may affect the power tool's operation. If damaged, have the power tool repaired before use.** Many accidents are caused by poorly maintained power tools.
  - f) **Keep cutting tools sharp and clean.** Properly maintained cutting tools with sharp cutting edges are less likely to bind and are easier to control.
  - g) **Use the power tool, accessories and tool bits etc. in**

**accordance with these instructions, taking into account the working conditions and the work to be performed.**

*Use of the power tool for operations different from those intended could result in a hazardous situation.*

**5. SERVICE**

- a) **Have your power tool serviced by a qualified repair person using only identical replacement parts. This will ensure that the safety of the power tool is maintained.**

## HAMMER SAFETY WARNINGS

- 1. Wear ear protectors.** *Exposure to noise can cause hearing loss.*
- 2. Use auxiliary handle(s), if supplied with the tool.** *Loss of control can cause personal injury.*
- 3. Always wear a dust mask.**
- 4. Hold power tool by insulated gripping surfaces, when performing an operation where the cutting accessory may contact hidden wiring or its own cord.** *Cutting accessory contacting a "live" wire may make exposed metal parts of the power tool "live" and could give the operator an electric shock.*

# COMPONENT LIST

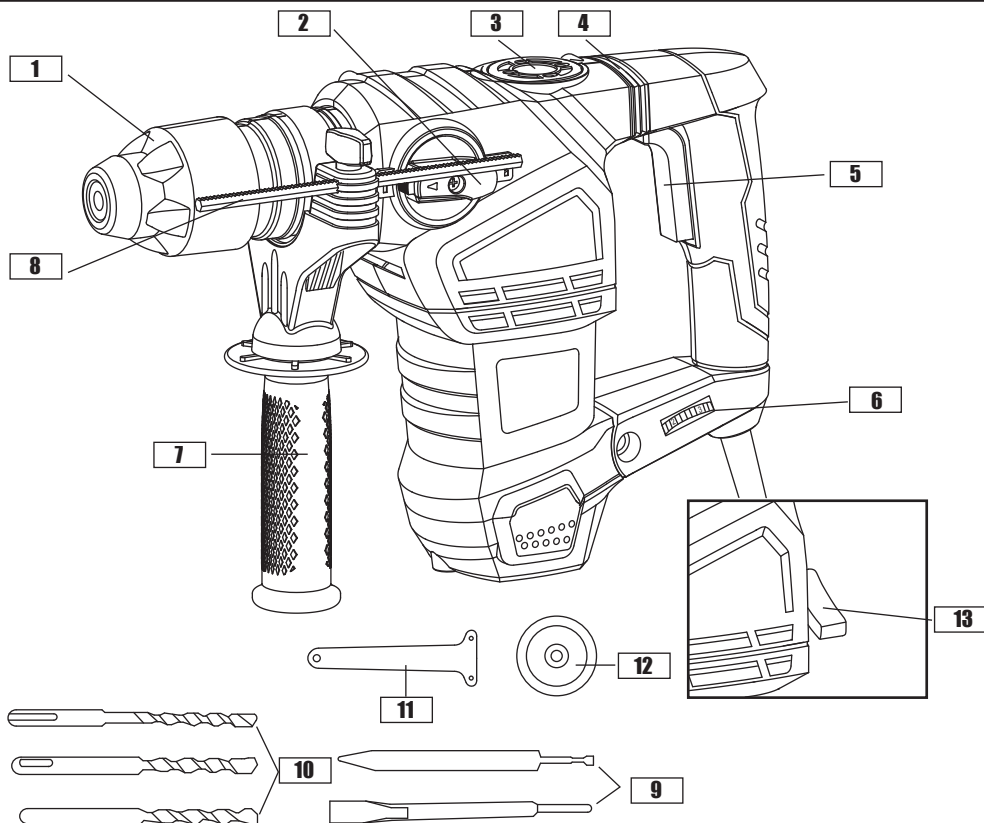

- 1** Locking sleeve
- 2** Hammer or chisel action selector switch
- 3** Grease box cover
- 4** Anti-vibration handle
- 5** On / Off switch
- 6** Variable speed control

- 7** Auxiliary handle
- 8** Depth gauge
- 9** SDS Chisel(flat & pointed)
- 10** SDS Drill bit
- 11** Spanner
- 12** Dust cover
- 13** Hammer or drilling action selector switch

## ACCESSORIES

Auxiliary handle	1
Depth gauge	1
Dust cover	1
Spanner	1
SDS drill bits (8/10/12 x 150mm)	3
SDS chisels (flat & pointed 250mm)	2

We recommend that you purchase your accessories from the same store that sold you the tool. Use good quality accessories marked with a well-known brand name. Choose the type according to the work you intend to undertake. Refer to the accessory packaging for further details. Store personnel can assist you and offer advice.

## SYMBOLS



To reduce the risk of injury, read all of this instruction manual



Warning



Wear ear protection



Wear eye protection



Wear dust mask



Double insulated



Waste electrical products must not be disposed of with household waste. Please recycle where facilities exist. Check with your local authorities or retailer for recycling advice.

## TECHNICAL DATA

Voltage	230-240V~50Hz
Power input	1500W
No load speed	200~850/min
Impact rate	1700~4200/min
Impact energy	5.5J
Max drilling capacity	
Steel	13mm
Masonry	32mm
Wood	40mm
Protection class	□/II
Machine weight	4.88kg

# NOISE INFORMATION

A weighted sound pressure

A weighted sound power

$K_{pA}$  &  $K_{wA}$

Wear ear protection when sound pressure is over:

$L_{pA}$ : 96.4dB(A)

$L_{wA}$ : 107.4dB(A)

3.0dB(A)

80dB(A) 

# VIBRATION INFORMATION

Vibration total values (triax vector sum) determined according to EN60745:	
Hammer drilling into concrete	Hammer drill into concrete $a_{h,HD} = 19.372m/s^2$
	Uncertainty $K=1.5m/s^2$
Chiseling	Chiselling $a_{h,Chesq} = 17.879m/s^2$
	Uncertainty $K=1.5m/s^2$

The declared vibration total value may be used for comparing one tool with another, and may also be used in a preliminary assessment of exposure.

 **WARNING!** The vibration emission value during actual use of the power tool can differ from the declared value depending on the ways in which the tool is used dependant on the following examples and other variations on how the tool is used:

How the tool is used and the materials being drilled.

The tool being in good condition and well maintained.

The use the correct accessory for the tool and ensuring it is sharp and in good condition.

The tightness of the grip on the handles and if any anti vibration accessories are used.

And the tool is being used as intended by its design and these instructions.

**This tool may cause hand-arm vibration syndrome if its use is not adequately managed.**

 **WARNING!** To be accurate, an estimation of exposure level in the actual conditions of use should also take account of all parts of the operating cycle such as the times when the tool is switched off and when it is running idle but not actually doing the job. This may significantly reduce the exposure level over the total working period, helping to minimize your vibration exposure risk.

ALWAYS use sharp chisels, drills.

Maintain this tool in accordance with these instructions and keep well lubricated (where appropriate).

If the tool is to be used regularly then invest in anti vibration accessories.

Plan your work schedule to spread any high vibration tool use across a number of days.

# OPERATING INSTRUCTIONS



**NOTE:** Before using the tool, read the instruction book carefully.

## Intended Use

The machine is intended for hammer drilling in concrete, brick and stone as well as for light chiseling work. It is also suitable for drilling without impact in wood, metal, ceramic and plastic.

## 1. INSERTING AND REMOVING DRILL BIT/ CHISEL (See Fig. A1,A2)

### INSERTING

Clean the bit shank and apply grease before installing the bit. Hold the rotary grip, pull back the locking sleeve (1) and insert the bits into the chuck. Turn the SDS tool and push it in until resistance is felt, and shaft is inserted completely into the chuck. Once you are satisfied it has seated, release the black locking sleeve. The SDS tool should be locked in position.

After installing always make sure that the tool is securely held in the chuck by trying to pull it out.

If the SDS tool is not correctly located, repeat the installation operation

### REMOVING

To remove the bit, pull back the locking sleeve (1), hold and pull the bit out.

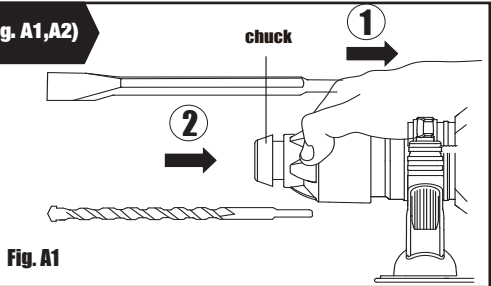

Fig. A1

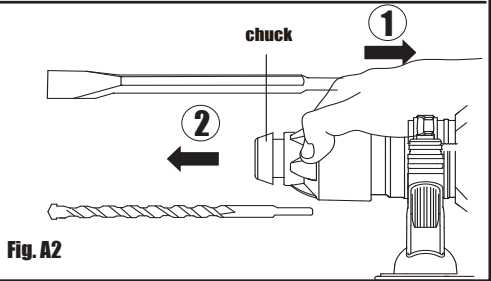

Fig. A2

## 2. Clamping the Auxiliary Handle (See Fig. B)

Rotate the handgrip counter-clockwise to loosen the auxiliary handle.

Slide the auxiliary handle (7) onto the drill and rotate to the desired working position. Rotate the handgrip clockwise to clamp the auxiliary handle. Always use the auxiliary handle in operation.



**CAUTION:** Always check and rotate the handle tightly before using to avoid any accident.

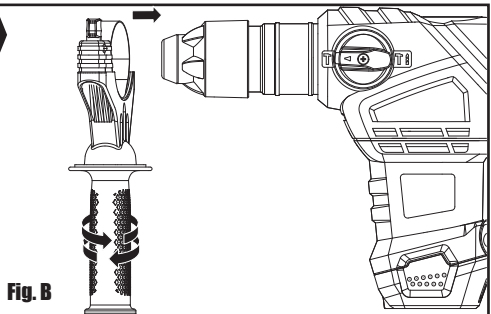

Fig. B

## 3. ANTI-VIBRATION HANDLE

The Anti-vibration handle reduces the vibration, making operation more comfortable and secure.



#### 4. USING THE DEPTH GAUGE (See Fig. C)

The depth gauge (8) can be used to set a constant depth to the drill.

Rotate the locking screw on the top of the handle anti-clockwise to loosen, insert the depth gauge (8) into the handle.

Adjust it to the desired depth. Rotate the locking screw clockwise to tighten.

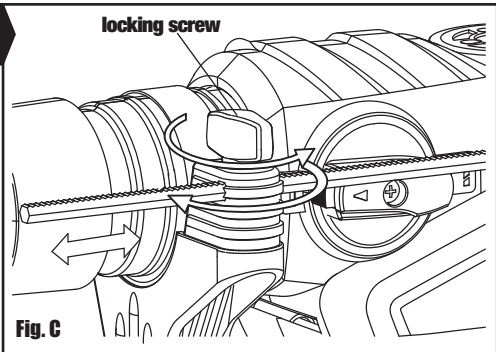

#### 5. ON/OFF SWITCH (See Fig. D)

Depress the On/Off switch (5) to start and release it to stop your tool.

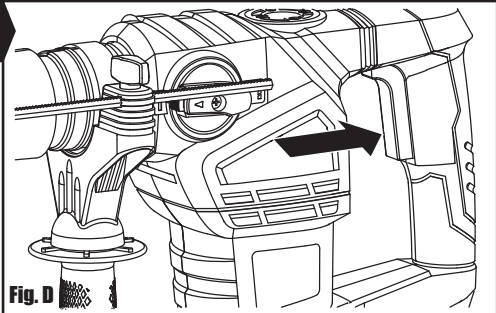

#### 6. HAMMER DRILL FUNCTION (See Fig. E1, E2)

1. Adjust the hammer or chisel action selector (2) to position "H" (See Fig. E1)
2. Adjust the hammer or drilling action selector (13) to position "H" (See Fig. E2)
3. You are now set up for hammer drilling into masonry.

**NOTE: Press the selector switch lock button before adjusting the dial selector everytime.**

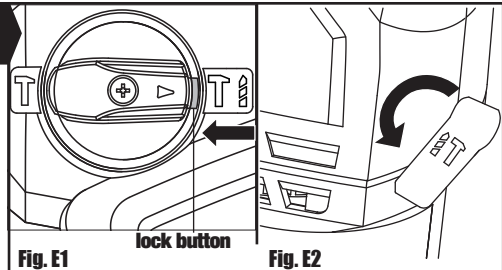

#### 7. DRILLING FUNCTION (See Fig. F1, F2)

1. Adjust the hammer or chisel action selector (2) to position "D" (See Fig. F1)
2. Adjust the hammer and drilling action selector (13) to position "D" (See Fig. F2)
3. You are now set up for drilling without hammer..

**NOTE: Press the selector switch lock button before adjusting the dial selector everytime.**

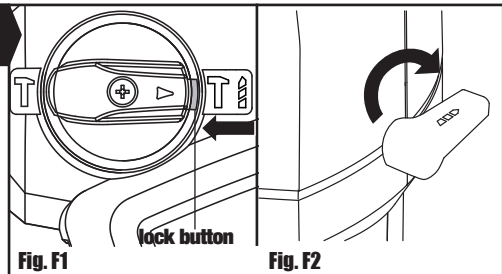

## 8. CHISEL FUNCTION (See Fig. G1, G2)

1. Adjust the hammer and chisel action selector (2) to position "T". (See Fig. G1)
2. Adjust the hammer and drilling action selector (13) to position "T". (See Fig. G2)
3. You are now set to chisel without rotation.

**NOTE: Press the selector switch lock button before adjusting the dial selector everytime.**

**WARNING:** You must make sure that the selector switch is positively locked in chisel mode position. If not, it could cause a hazard.

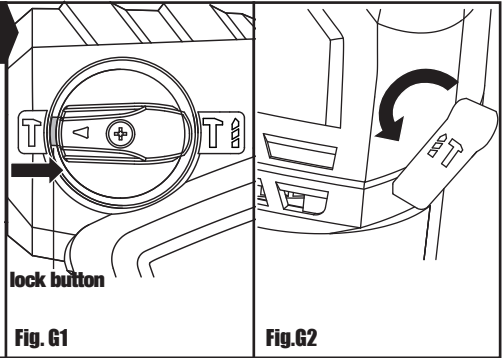

## 9. DUST COVER (See Fig. H)

Before drilling, fit the dust cover (12) over the drill bit.

**CAUTION:** Always wear eye protection with this tool.

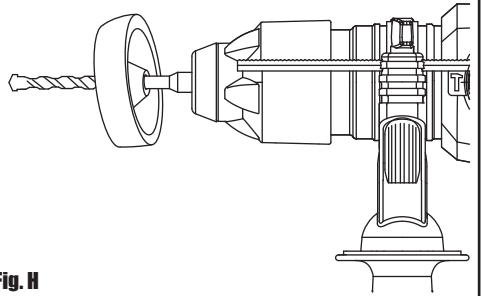

## 10. LUBRICATION (See Fig. I)

The gearbox is lubricated with grease. Refilling is required when the hammer efficiency is low. Open the cover using the spanner (11) provided and add general purpose lithium based grease.

**CAUTION:** Keep the container of grease away from children.

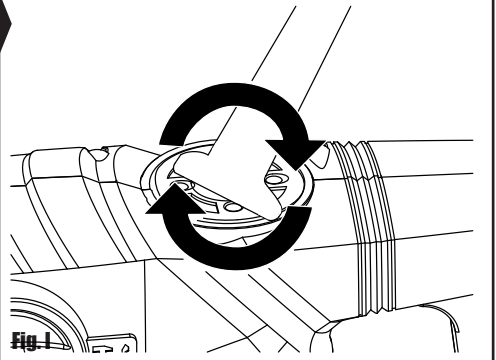

## 11. SAFETY CLUTCH PROTECTION

This tool will generate high forces when use. Always hold the tool with both hands and adopt a secure posture. If the drill bit or chisel becomes jammed in the workpiece, the clutch will activate stopping the tool spindle. This is normal. Switch the machine off, loosen and remove the drill bit or chisel from the work piece.

**CAUTION:** Switching the machine on with the drill bit or chisel jammed in the work piece will generate high reaction torque and can result in injury.

## 12. VARIABLE SPEED CONTROL (See Fig. J)

The speed increases as you adjust the thumb-wheel (6) towards the higher number and decreases on the lower number.

Avoid prolonged use at very low speed as this may cause damage.

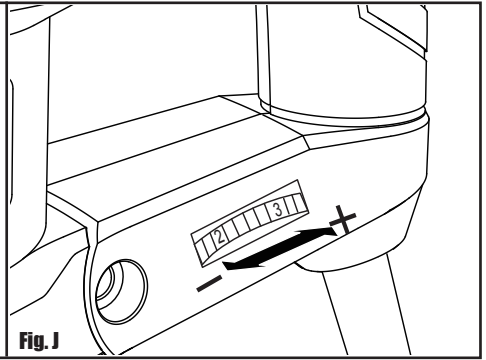

Fig. J

## WORKING HINTS FOR YOUR ROTARY HAMMER DRILL

1. Reduce the pressure on the drill bit when it is about to break through. This will prevent the drill from jamming.
2. When drilling a large hole, first drill a pilot hole using a smaller drill bit.
3. Always apply pressure to your drill bit in a straight line, and if possible at right angles to the workpiece.
4. Never change the operating mode whilst the drill is running.
5. Do not apply excessive pressure to the tool when chiseling. Excessive force does not speed up the work.

## MAINTENANCE

Remove the plug from the socket before carrying out any adjustment, servicing or maintenance.

There are no user serviceable parts in your power tool. Never use water or chemical cleaners to clean your power tool. Wipe clean with a dry cloth. Always store your power tool in a dry place. Keep the motor ventilation slots clean. Keep all working controls free of dust. Occasionally you may see sparks through the ventilation slots. This is normal and will not damage your power tool.

If the supply cord is damaged, it must be replaced by the manufacturer, its service agent or similarly qualified persons in order to avoid a hazard.

## TROUBLESHOOTING

1. If your power tool does not start, check the plug on the power supply first.
2. If your drill becomes too hot in use, set the hammer switch to the drill mode and allow your drill to operate at maximum speed without load for 2 minutes.
3. If your hammer work efficiency is too low, please add sufficient grease in the grease box.
4. If work efficiency is too low please check drill bit or chisel and make sure it is not blunt or worn.
5. If a fault can not be rectified, return the tool to an authorized dealer for repair.

## ENVIRONMENTAL PROTECTION



Waste electrical products should not be disposed of with household waste. Please recycle where facilities exist. Check with your Local Authority or retailer for recycling advice.

## PLUG REPLACEMENT (ONLY FOR REWIRABLE PLUG OF UK & IRELAND)

If you need to replace the fitted plug then follow the instructions below.

### IMPORTANT

The wires in the mains lead are colored in accordance with the following code:

Blue = Neutral

Brown = Live

As the colors of the wires in the mains lead of this appliance may not correspond with the colored markings identifying the terminals in your plug, proceed as follows. The wire which is colored blue must be connected to the terminal which is marked with N. The wire which is colored brown must be connected to the terminal which is marked with L.

### Warning!

Never connect live or neutral wires to the earth terminal of the plug. Only fit an approved 13A BS1363/A plug and the correct rated fuse.

Note: If a moulded plug is fitted and has to be removed take great care in disposing of the plug and severed cable, it must be destroyed to prevent engaging into a socket.

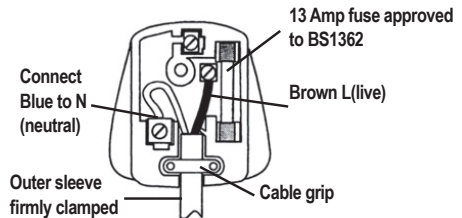

# DECLARATION OF CONFORMITY

We,  
**Wickes Building Supplies Limited**

**Declare that this product: HAMMER DRILL**

*Description and SKU code: 223724*

**Complies with the following Directives and Regulations:**

2006/42/EC, Machinery Directive

2014/30/EU, Electromagnetic Compatibility Directive

2011/65/EU & (EU)2015/863, Restriction of Hazardous Substances Directive

**and conforms to the following standards:**

*Standards specific to this product:*

**EN 60745-1**

**EN 60745-2-6**

**EN 55014-1**

**EN 55014-2**

**EN 61000-3-2**

**EN 61000-3-3**

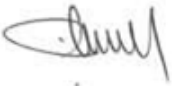

28<sup>th</sup> January, 2021

Philip Ansell

Category Technical Manager

Wickes

Vision House

19 Colonial Way

Watford

WD24 4JL”



**Customer Helpline 0345 2005409**