

0619AXNE3326HGDD2SW-V1

19MM LOG CABIN, APEX, NO EXTRAS, 3.3X2.6M, HALF GLAZED DOUBLE DOORS, 2 SHORTWINDOWS

BEFORE YOU START PLEASE READ INSTRUCTIONS CAREFULLY

- Check the pack and make sure you have all the parts listed.
- When you are ready to start, make sure you have the right tools at hand (not supplied) including a Phillips screwdriver, Stanley knife, wood saw, step ladder and drill with 2mm bit.
- Ensure there is plenty of space and a clean dry area for assembly.

TIMBER

As with all natural materials, timber can be affected during various weather conditions. For the duration of heavy or extended periods of rain, swelling of the wood panels may occur. Warping of the wood may also occur during excessive dry spells due to an interior moisture loss. Unfortunately, these processes cannot be avoided but can be helped. It is suggested that the outdoor building is sprayed with water during extended periods of warm sunshine and sheltered as much as possible during rain or snow.

BUILDING A BASE

When thinking about where the building and base are going to be constructed: Ensure that there will be access (60cm) to all sides for maintenance work and annual treatment.

Ensure the base is level and is built on firm ground, to prevent distortion. Refer to diagrams for the base dimensions. The base should be slightly smaller than the external measurement of the building, i.e. The cladding should overlap the base, creating a run off for water. It is also recommended that the floor be at least 25mm above the surrounding ground level to avoid flooding.

TYPES OF BASE

- Concrete 75mm laid on top of 75mm hard-core.
- Slabs laid on 50mm of sharp sand.

Whilst all products manufactured are made to the highest standards of Safety and in the case of childrens products independently tested to EN71 level, we cannot accept responsibility for your safety whilst erecting or using this product.

Refer to the instructions pages for your specific product code



All buildings should be erected by two adults



Winter = High Moisture = Expansion
Summer = Low Moisture = Contraction



2mm Drill bit

For ease of assembly, you **MUST** pilot drill all screw holes and ensure all screw heads are countersunk.



CAUTION
Every effort has been made during the manufacturing process to eliminate the prospect of splinters on rough surfaces of the timber. You are strongly advised to wear gloves when working with or handling rough sawn timber.



For ease of assembly use a rubber mallet to fit the log boards. Do **NOT** use a heavy hammer.



Ensure to measure and check before cutting boards.

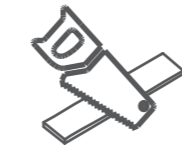

It is advisable to use a hand saw when cutting roof and floor boards.



To ensure log boards are even, use a spirit level to check each layer has been installed correctly.

Screws & Nails



Bolts



To identify the fixings required for each step use a measuring tape.

For assistance please contact customer care on: 01636 821215

**Mercia Garden Products Limited,
Sutton On Trent,
Newark,
Nottinghamshire,
NG23 6QN**

www.merciagardenproducts.co.uk



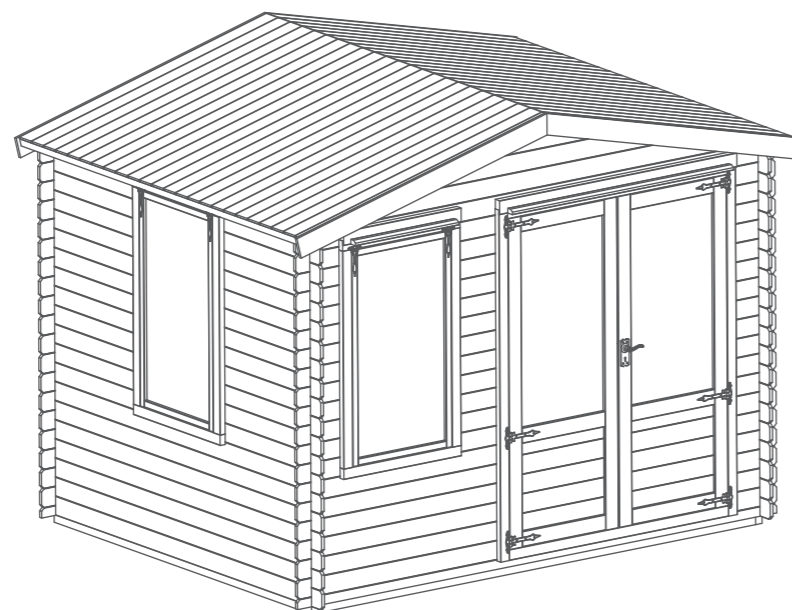

Overall Dimensions:
 Width = 3445mm
 Depth = 2636mm
 Height = 2642mm

Base Dimensions:
 Width = 3099mm
 Depth = 2403mm



Window Contents

-  **1**

Window Frame Left Upright - 71x70x1412mm Qty 2
 AI-0619LOGWUFL-V3
- 

Window Frame Right Upright - 71x70x1412mm Qty 2
 AI-0619LOGWUFR-V3
- 

Window Frame Top - 81x125x805mm Qty 2
 AI-0619LOGSWTF-V3
- 

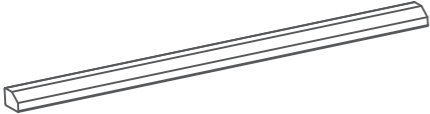
Window Frame Bottom - 71x70x805mm Qty 2
 AI-0619LOGSWBF-V3
- 

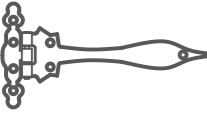
Rain Guards QTY 2
 RG2844-710 (28x44x710mm)
- 

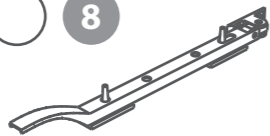
6 Inch T-Hinge QTY 4
 PI-07-0113
- 

Casement Stay Qty 2
 PI-07-0008

Double Door Contents

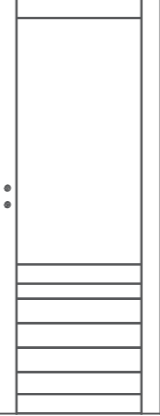
-  **9**

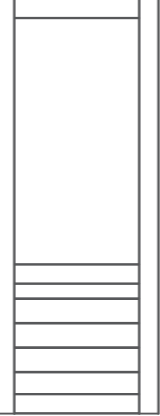

Master Door
 (Morticed for lock)
 AI-06LOGSANGHGMD750X1900-V1
-  **10**

Slave Door
 AI-06LOGSANGHGSD750X1900-V1
- 

Door Frame Left Upright - 71x70x2065mm
 AI-0619LOGDUFL-V3
- 

Door Frame Right Upright - 71x70x2065mm
 AI-0619LOGDUFR-V3
- 

Door Frame Top - 81x125x1632mm
 AI-0619LOGDDTF-V3
- 

Door Frame Bottom - 71x70x1508mm
 AI-0619LOGDDBF-V3
- 

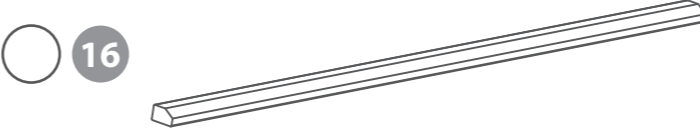
Door Strip - 16x60x1880mm
 S1660-1880mm
- 

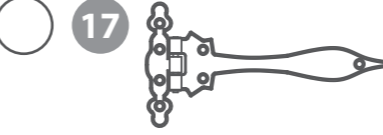
Rain Guard QTY 1
 RG2844-1520 (28x44x1520mm)
- 

9 Inch T-Hinge QTY 6
 PI-07-0002
- 

Handles (Pair)
 PI-07-0006
- 

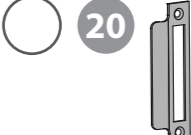
Mortice Lock
 PI-07-0017
- 

Key Plate
- 

Tower Bolt QTY 2
 PI-07-0114

Main Building Contents

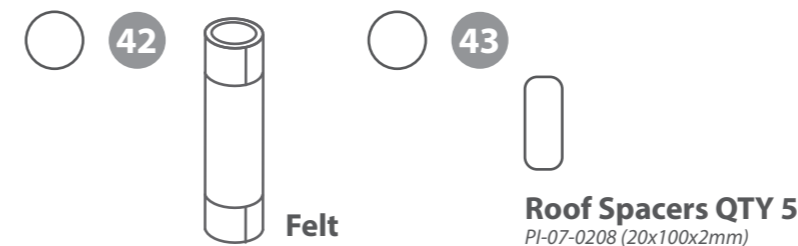
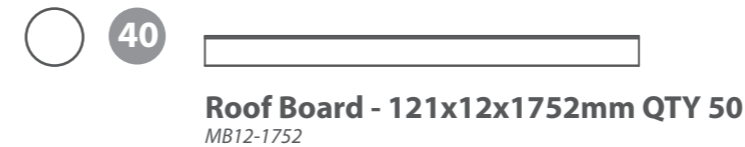
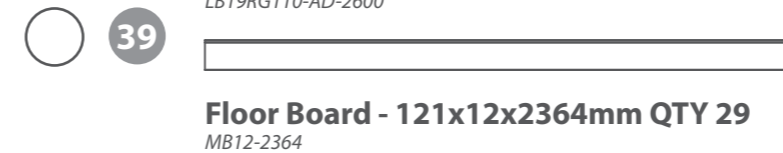
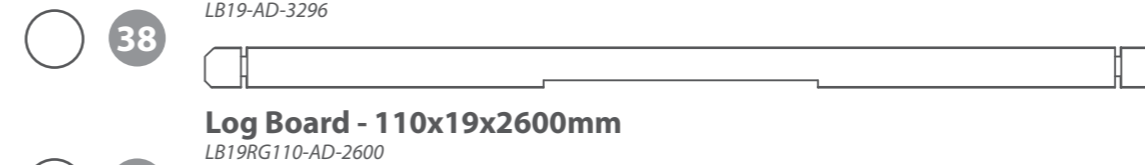
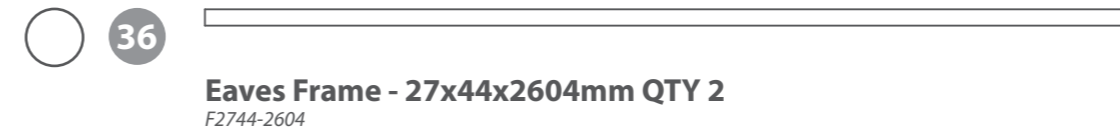
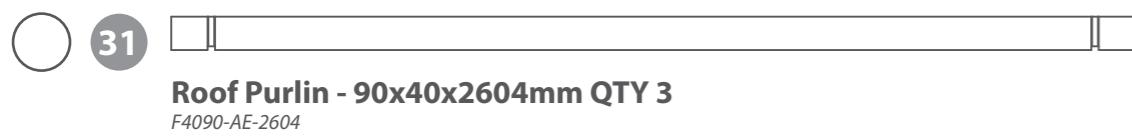
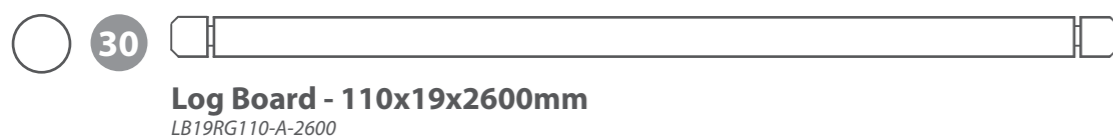
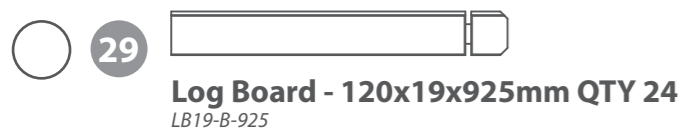
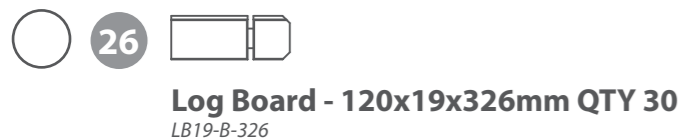
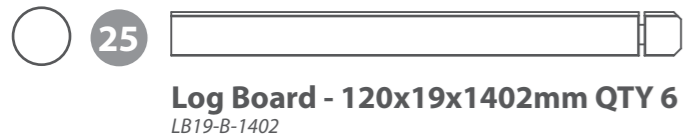
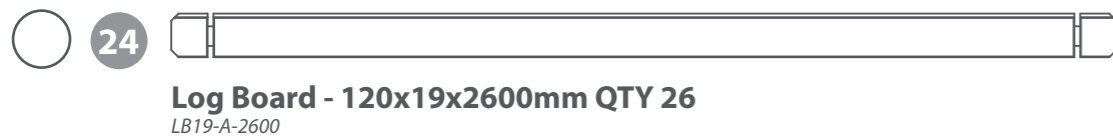
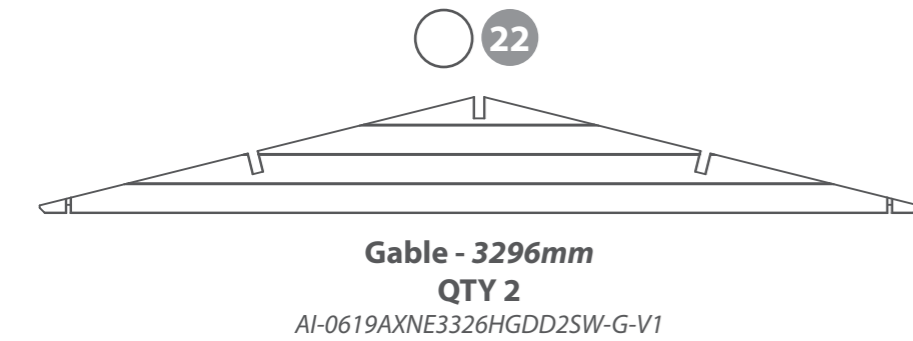

Nail Bag

There may be extra screws present in the nail bag



Pre-assembly

***Please note:**

Each board interlocks at either end in a staggered pattern.

Before securing ensure that the boards are fitted properly in their respective tongues and grooves.

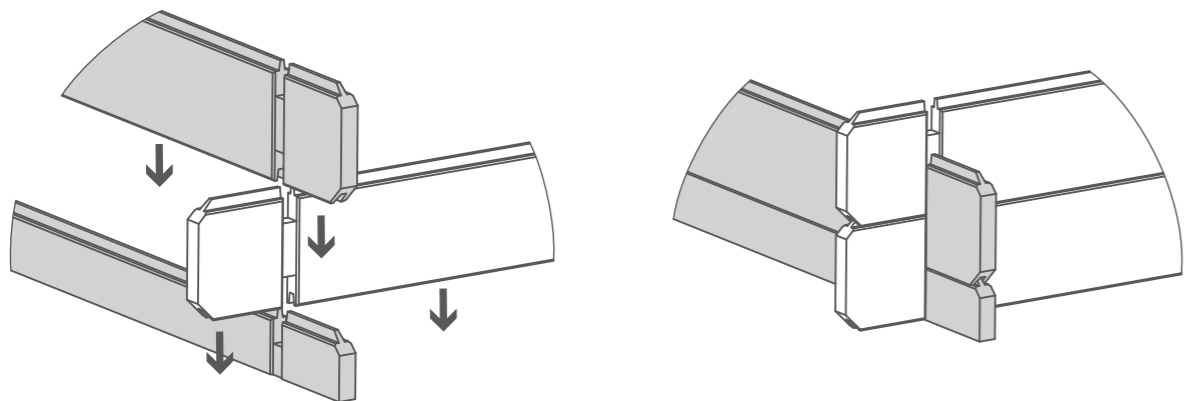

Step 1
Parts Needed - No. 32 QTY 2
No. 33 QTY 2

Lay the bearers (**No's. 32 & 33**) onto a firm and level surface (**free from areas where standing water can collect**) as shown in the illustration.

Fix the bearers together at each corner using 2 screws per corner using 8x70mm screws in total, ensuring the bearers are flush.

Once fully assembled, ensure the bearers are square by measuring from corner to corner as illustrated, making sure the measurements are equal.

If the bearers are not aligned equally, unscrew, adjust and re-align accordingly.

8x70mm Screws



IMPORTANT: Pre-drill before fixing screws.

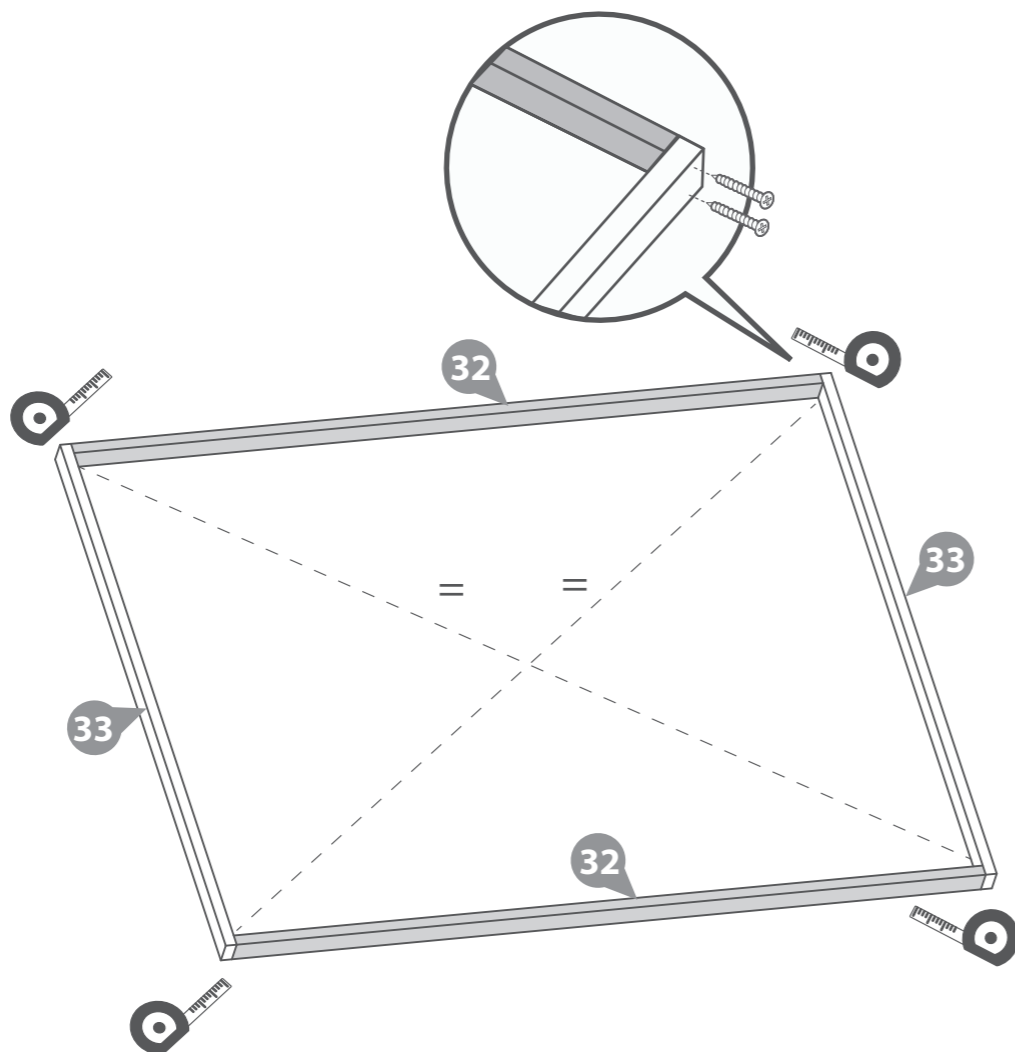

Step 2
Parts Needed - No. 32 QTY 8

Following the same method arrange the remaining bearers (**No. 32**) inside the assembled frame.

***Ensure there is an equal amount of space between each frame.**

Secure each of the bearers in place using 2x70mm screws for each side of the bearer, ensuring the bearers remain level.

32x70mm Screws



IMPORTANT: Pre-drill before fixing screws.

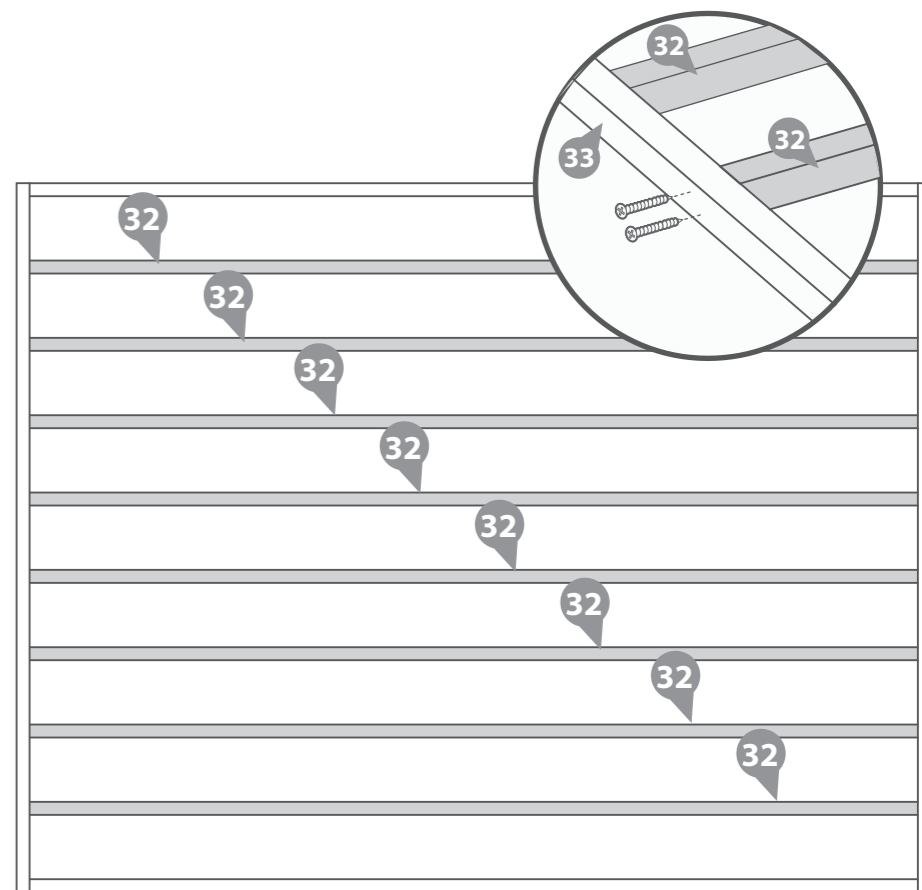

Step 3

Parts Needed - No. 23 QTY 2
No. 24 QTY 2

Place the starter boards (**No's. 23**) on to assembled base frame along the longest sides and place the first two log boards (**No. 24**) in the notch as shown.

Ensure the boards sit square on the base using the same method used in Step 1. Measure corner to corner, making sure the measurements are equal.

Once the boards are square, lift up the log board (**No. 24**) and fix the starter boards in place.

Fix each of the starter boards to the frame by screwing through the notch into the frame as shown in the illustration.

4x70mm Screws

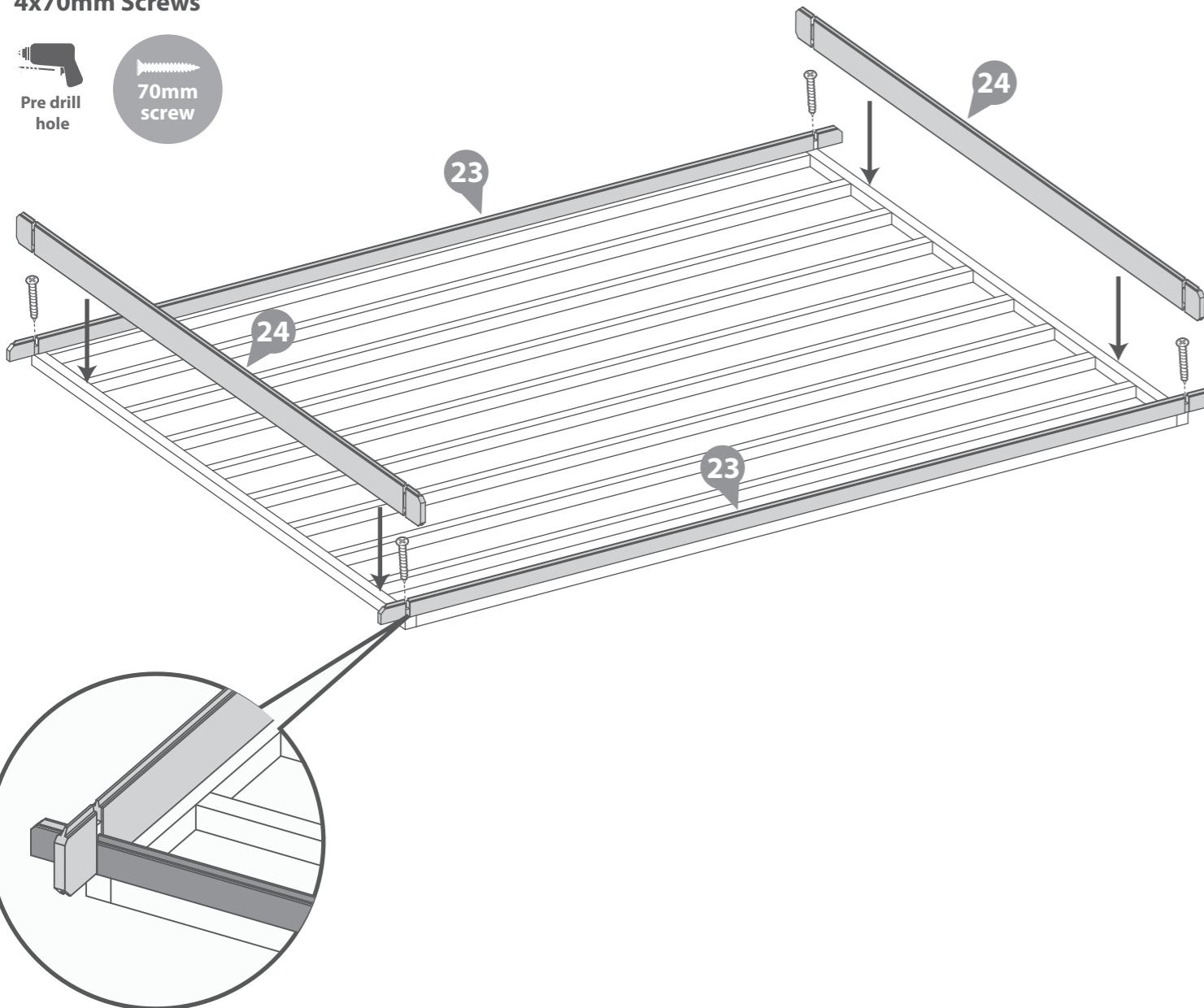
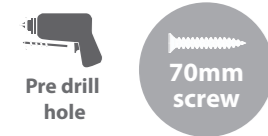

IMPORTANT: Pre-drill before fixing screws.

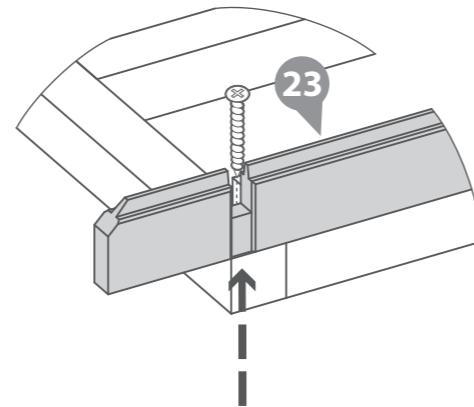

Step 4

Parts Needed - No. 24 QTY 12
No. 25 QTY 6
No. 26 QTY 6
No. 28 QTY 6

Following the method shown in the illustration, lay the first 6 boards (**No's. 24, 25, 26 & 28**)

Start by placing the front and back boards, interlocking them with the side boards. Then place the next side boards, interlocking with the front and back boards. Continue this method until you have placed **6 boards off of the starter boards on each side**, as shown in the illustration.

This will create your first level.

***Ensure that the boards are level and flush with each other as you lay each one.**

****Please Note:** The short boards at the front of the building (either side of the door and window opening's) can be placed either side depending on your needs.

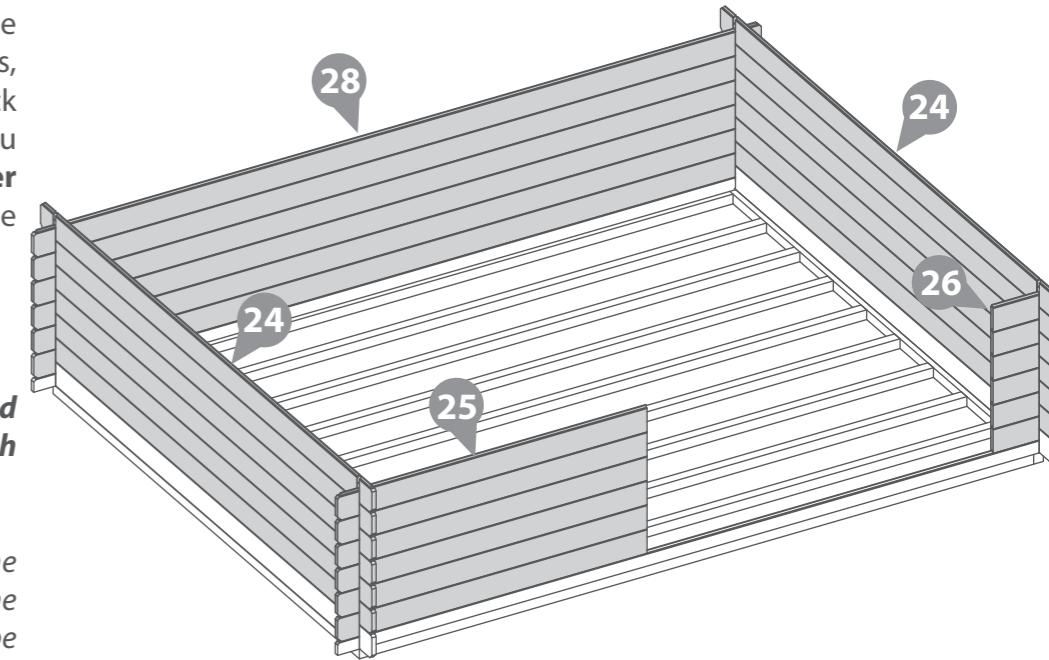
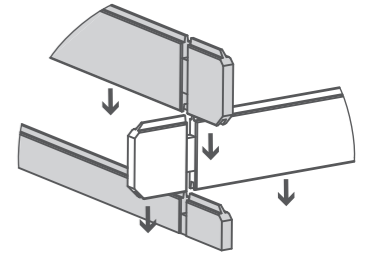

Step 5

- Parts Needed -** No. 11 QTY 1
 No. 12 QTY 1
 No. 13 QTY 1
 No. 14 QTY 1

Arrange the left, right, top & bottom door frames (No's. 11, 12, 13 & 14) onto a level surface. Secure the top and bottom frames to the uprights using 2x80mm screw per corner, ensuring the screws do **NOT** protrude through the front of the door framing.

8x80mm Screws

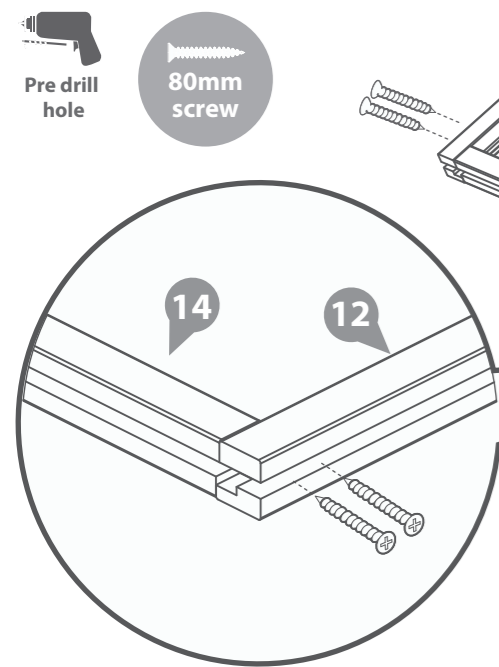

IMPORTANT : Pre-drill before fixing screws.

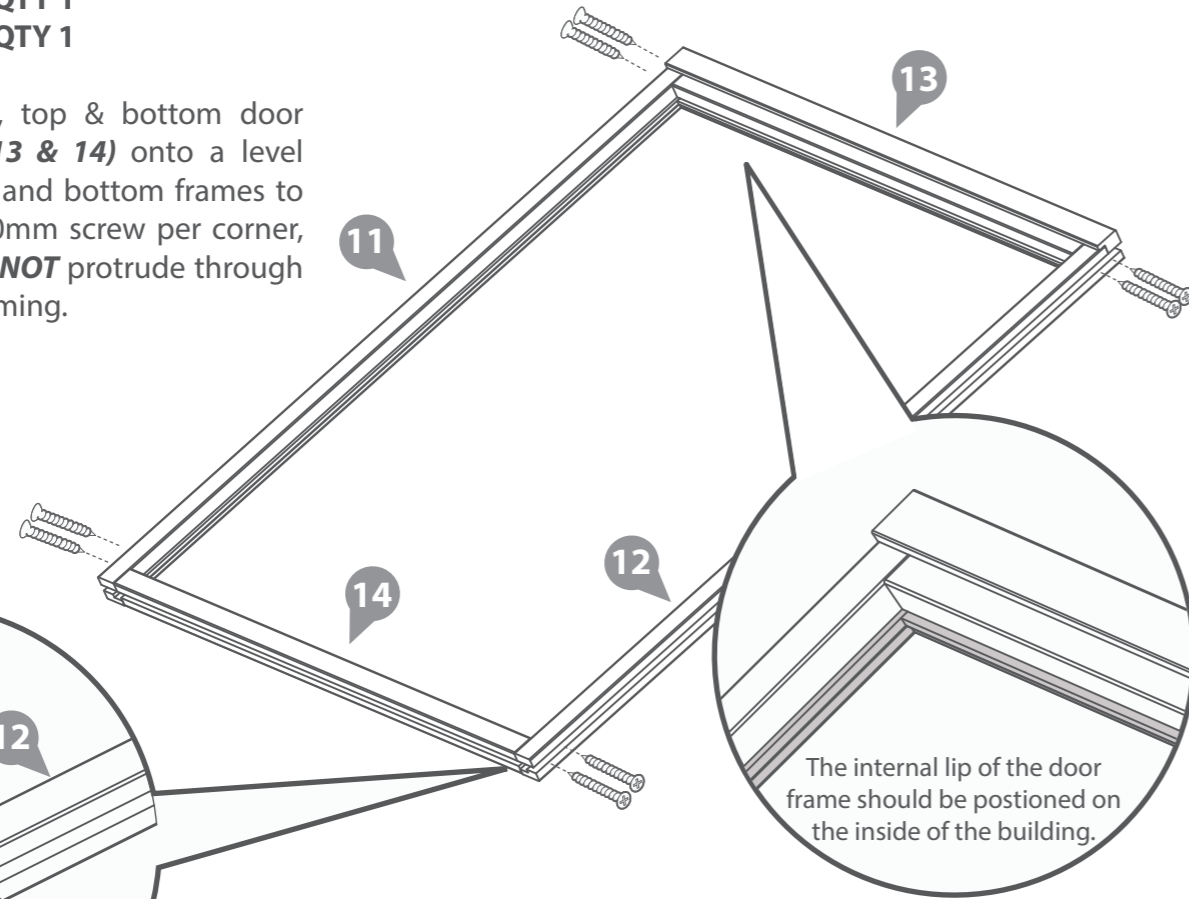

Step 7

- Parts Needed -** No. 24 QTY 6
 No. 26 QTY 12
 No. 27 QTY 6
 No. 28 QTY 6
 No. 29 QTY 12

Following the method shown in the illustration, lay the next 6 boards (No's. 24, 26, 27, 28 & 29) onto the log cabin to create your second level.

***Ensure that the boards are level and flush with each other as you lay each one.**

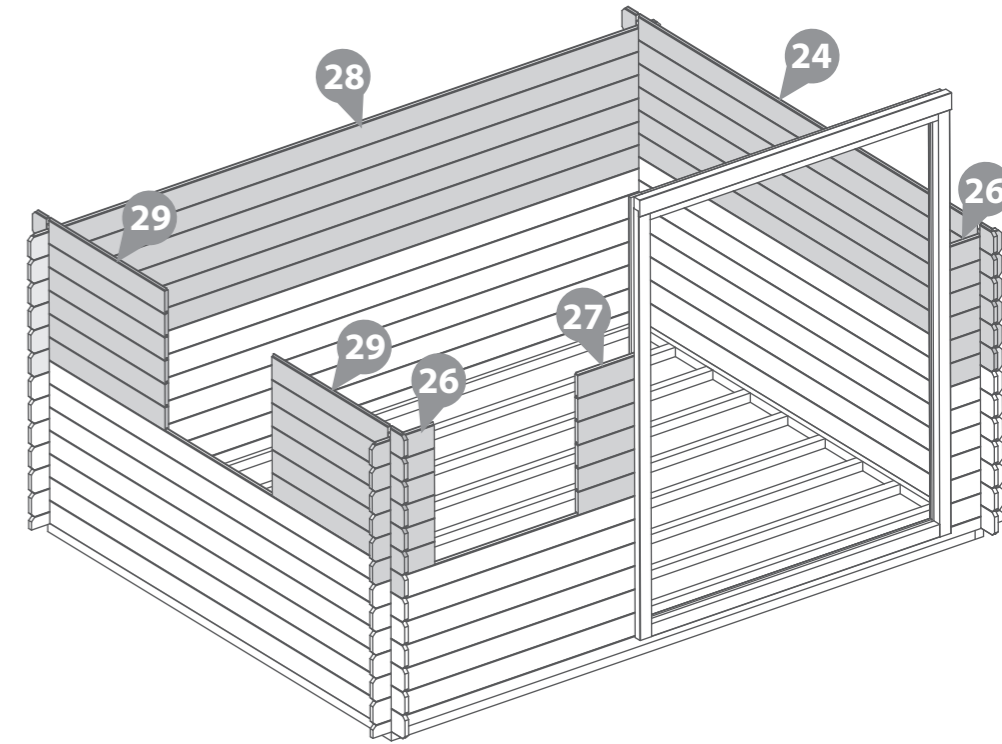
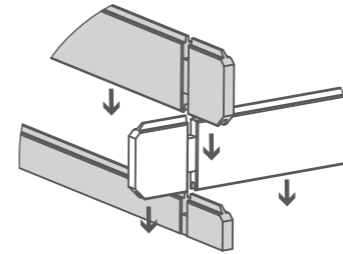

Step 6

Once you have laid 6 log boards (off of the starter) up the door section, slide the assembled door frame over the boards resting the frame on top of the starter board (**if you have not yet assembled the door frame refer to step 5**)

***Please note:** This image is for illustrative purposes and may differ from your choice in product (regarding door position). Nevertheless the process of fitting the door frame is the same.

****Please Note:** The short boards at the front of the building (either side of the door and window opening's) can be placed either side depending on your needs.

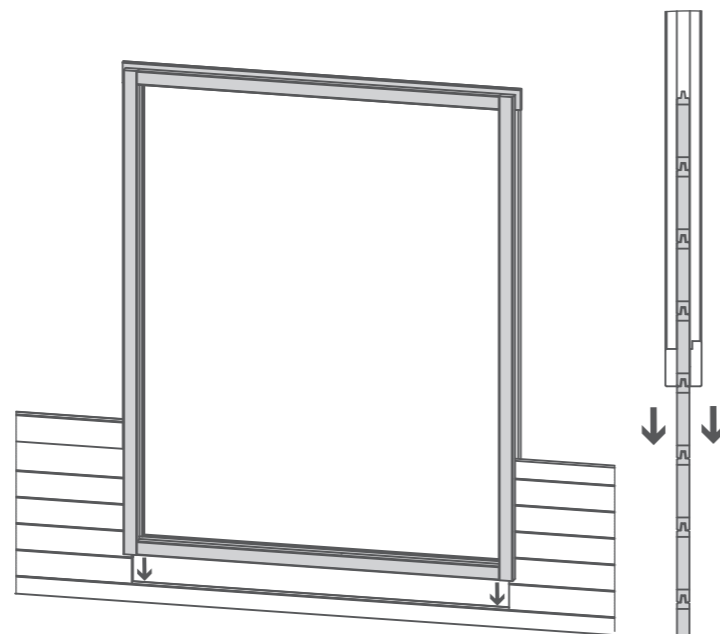

Step 8

- Parts Needed - No. 2 QTY 2**
No. 3 QTY 2
No. 4 QTY 2
No. 5 QTY 2

Arrange the left, right, top & bottom window frames (**No's. 2, 3, 4, & 5**) onto a firm and level surface. Secure the top and bottom frames to the uprights using 2x80mm screw per corner, ensuring the screws do **NOT** protrude through the front of the window framing.

Using the method outlined above assemble two window frames.

16x80mm Screws



80mm screw

IMPORTANT : Pre-drill before fixing screws.

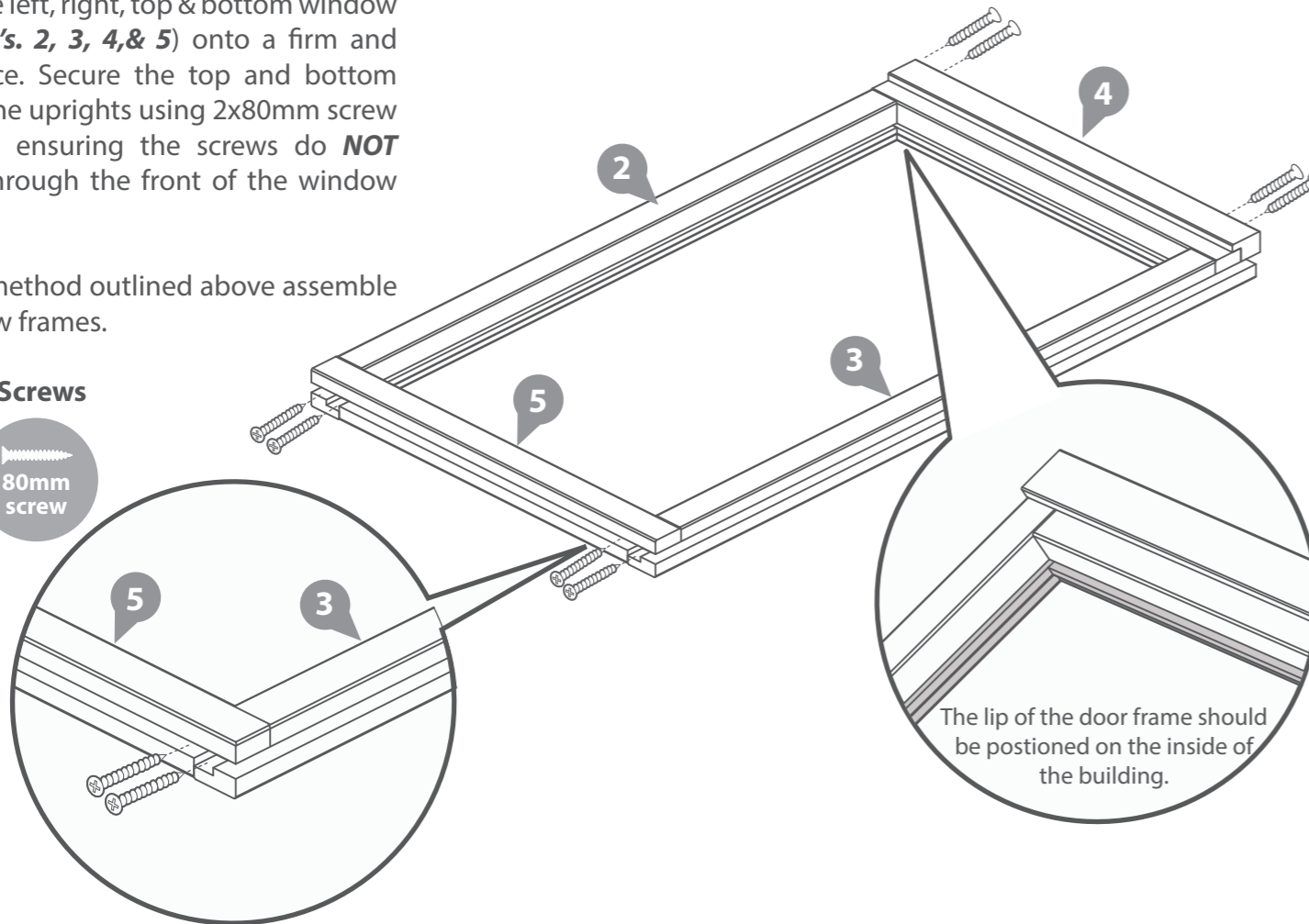

The lip of the door frame should be positioned on the inside of the building.

Step 9

Once you have laid the second level of boards onto the log cabin slide the window frame between the smaller boards and rest on to the longer board (**if you have not yet assembled the window frames refer to step 8**)

***Ensure the boards are level with each end.**

***Please note:** This image is for illustrative purposes and may differ from your choice in product (**regarding window position**). Nevertheless the process of fitting the window is the same.

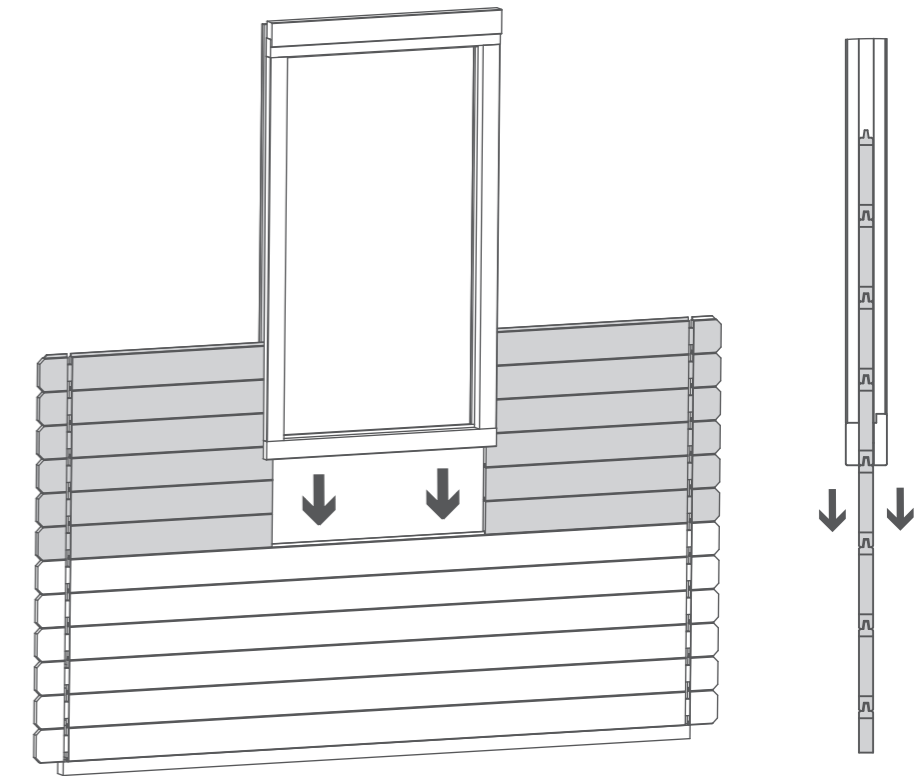

Step 10

- Parts Needed - No. 24 QTY 6**
No. 26 QTY 12
No. 27 QTY 6
No. 28 QTY 6
No. 29 QTY 12

Following the method shown in the illustration, lay a further 6 boards (**No's. 24, 26, 27, 28 & 29**) onto the log cabin to bring the board level to the top of the window and door frames.

***Ensure that the boards are level and flush with each other as you lay each one.**



Rubber Mallet may be required to fit parts.

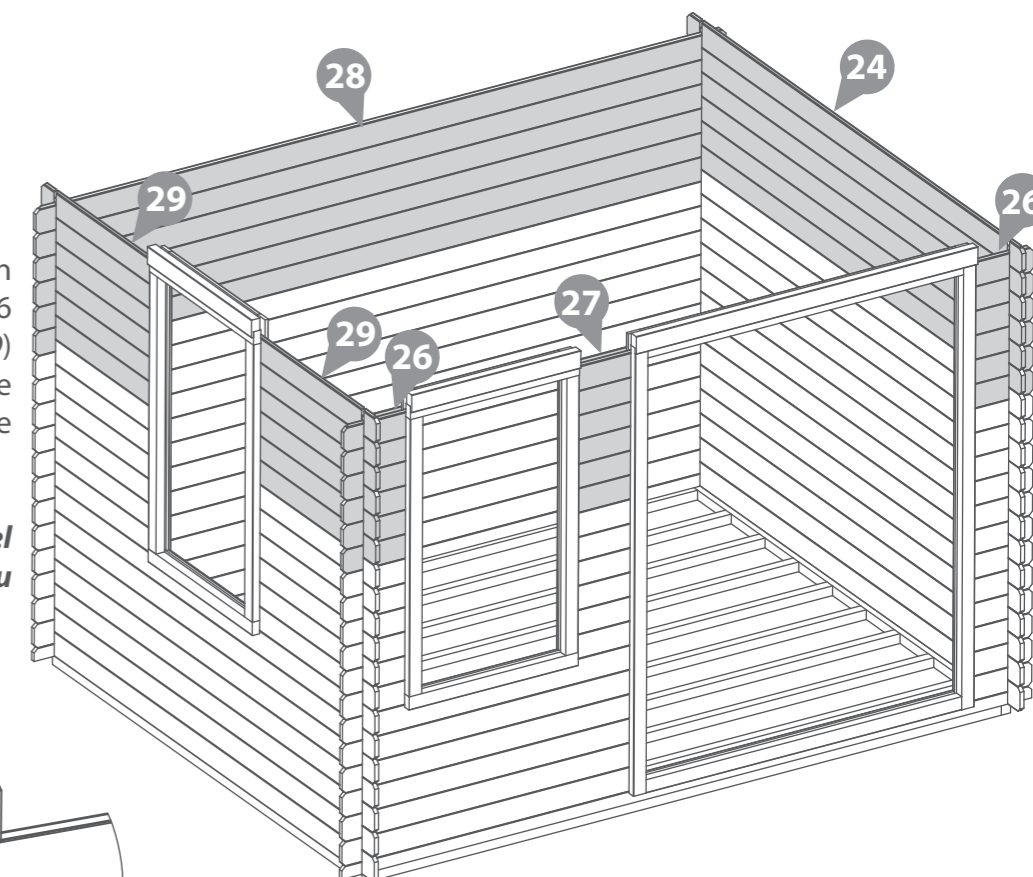
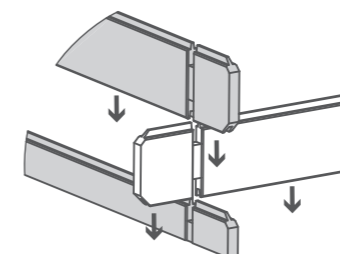

Step 11

- Parts Needed - No. 28 QTY 1**
No. 30 QTY 1
No. 37 QTY 1
No. 38 QTY 1

Following the method shown in the illustration, lay the last two boards (**No. 28 & 37**) onto the front and rear of the log cabin.

Once in position place the last two boards (**No. 30 & 38**) onto the window and plain side.

***Ensure that the boards are level and flush with each other as you lay each one.**

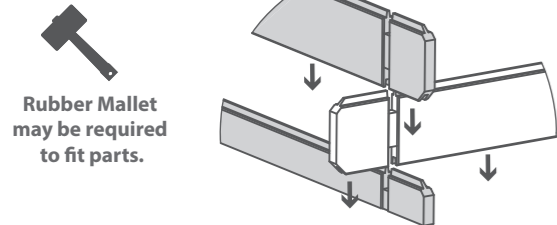
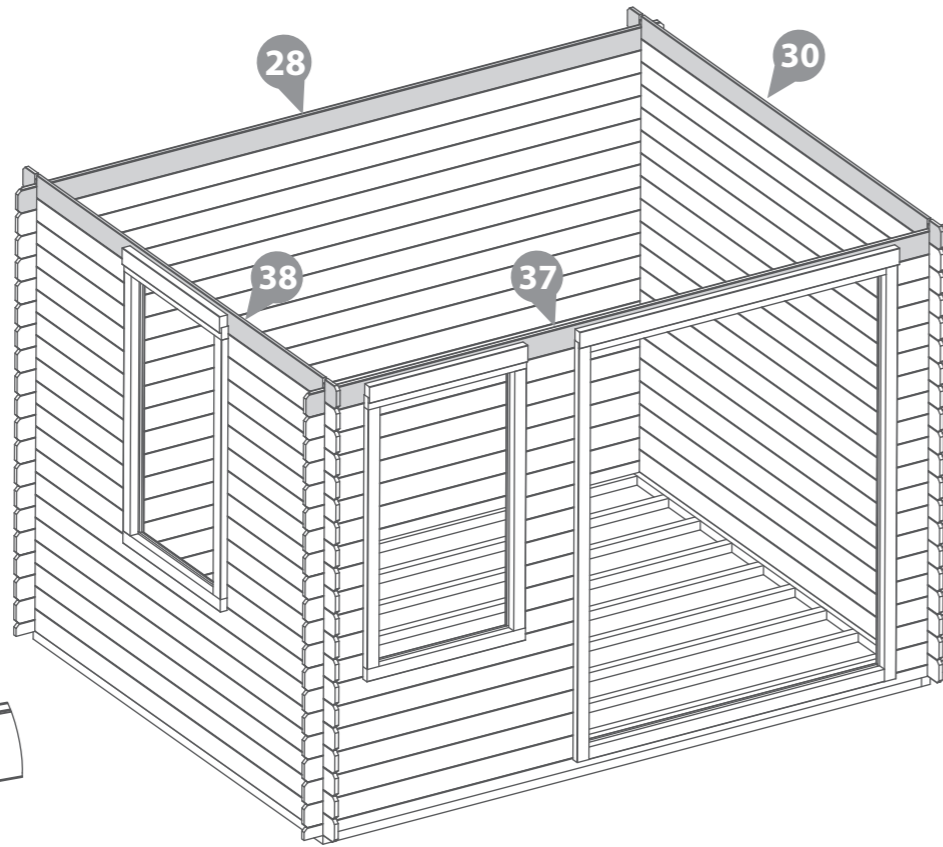

Step 12

- Parts Needed - No. 22 QTY 2**

Place the gable tops (**No. 22**) onto the log cabin. Fix into position by screwing through the notches as shown in the illustration.

***Ensure that the boards are level and flush with each other as you lay each one.**

- 4x70mm Screws**

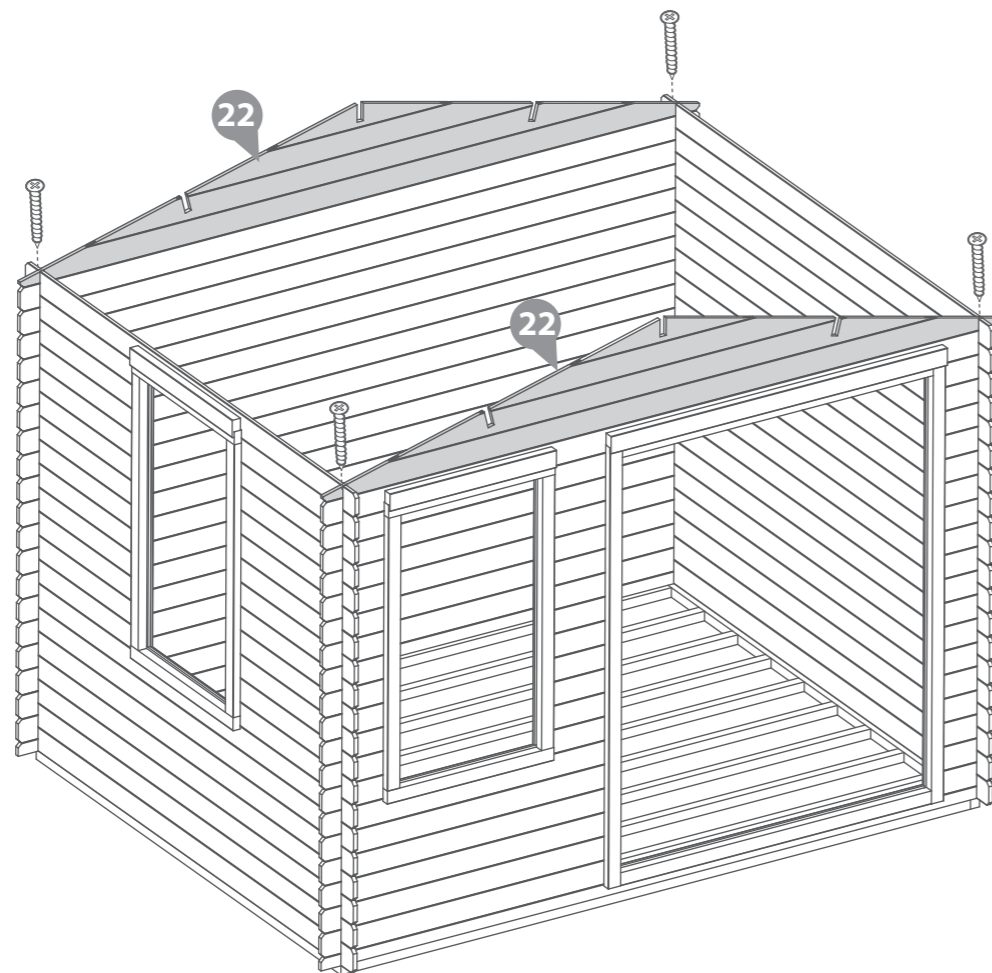
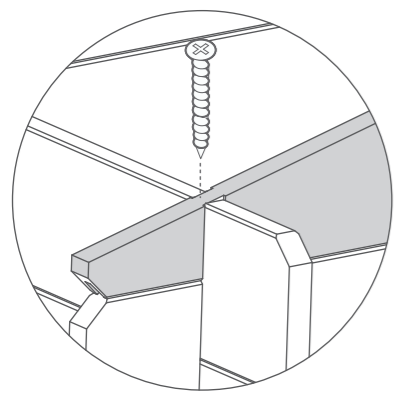
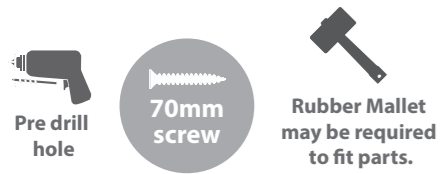

IMPORTANT: Pre-drill before fixing screws.

Step 13

- Parts needed - No. 31 QTY 3**

a Align the Roof Purlins (**No. 31**) into the cut out slots on each gable top ensuring each purlin interlocks into the boards.

b Secure the purlins at each end by screwing through the roof purlins into the boards (**ensure to pre-drill to avoid the boards splitting**) using 4x70mm screws per purlin.

***Please note:** The gable shown is for illustrative purposes and may differ in width from your choice in product. Nevertheless, despite any differences the process of fixing the purlins is the same.

- 12x70mm Screws**

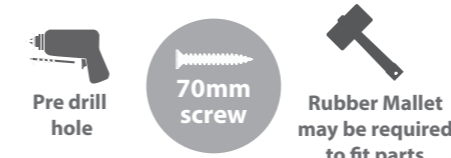

IMPORTANT: Pre-drill before fixing screws

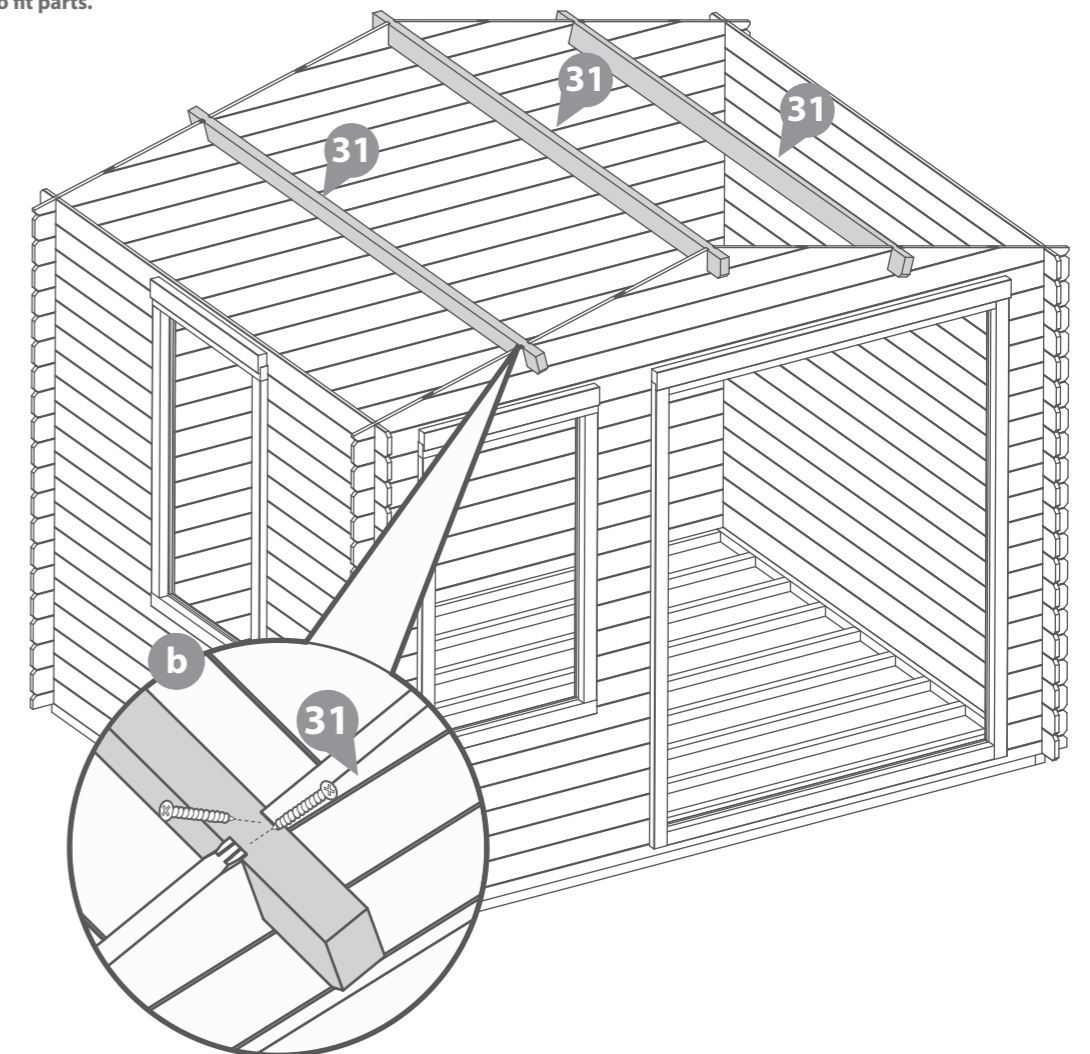
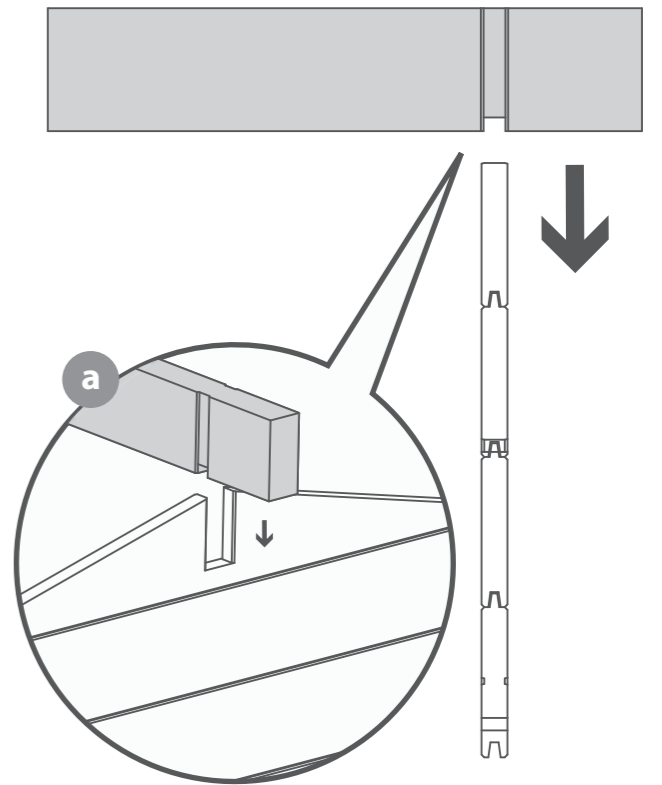

Step 14

Parts needed - No. 40 QTY 50

a Place the first two roof boards (**No.40**) onto the log cabin on each side, making sure the boards are flush to the end of the roof purlin. Once in position fix to each purlin using 3x40mm screws per board.

Use the spacer (**No. 43**) to create an expansion gap between each roof board if installing during low levels of moisture (summer). This creates an expansion gap for the boards to move into during high levels of moisture (winter).

Continue adding the roof boards along the roof, fixing each one into position using 3x40mm screws per board, making sure that each board is interlocked, flush at the bottom & meet at the top of the apex.

You have been issued with 50 roof boards, but in reality you may only need to use 48.

***Ensure the roof boards meet at the top of the apex and leave an overhang at the bottom.**

b The last board on each side will overhang at the front: Using a straight edge and a pencil mark out a line as a guide.

Cut along the pencil mark and remove the excess. Place the cut down board's back onto the roof and secure into place using 3x40mm screws per board.

***Please Note:** This image is for illustrative purposes and may differ from your choice in product. Nevertheless the process of cutting and fitting the last roof board(s) is the same.

150x40mm Screws



IMPORTANT: Pre-drill before fixing screws.

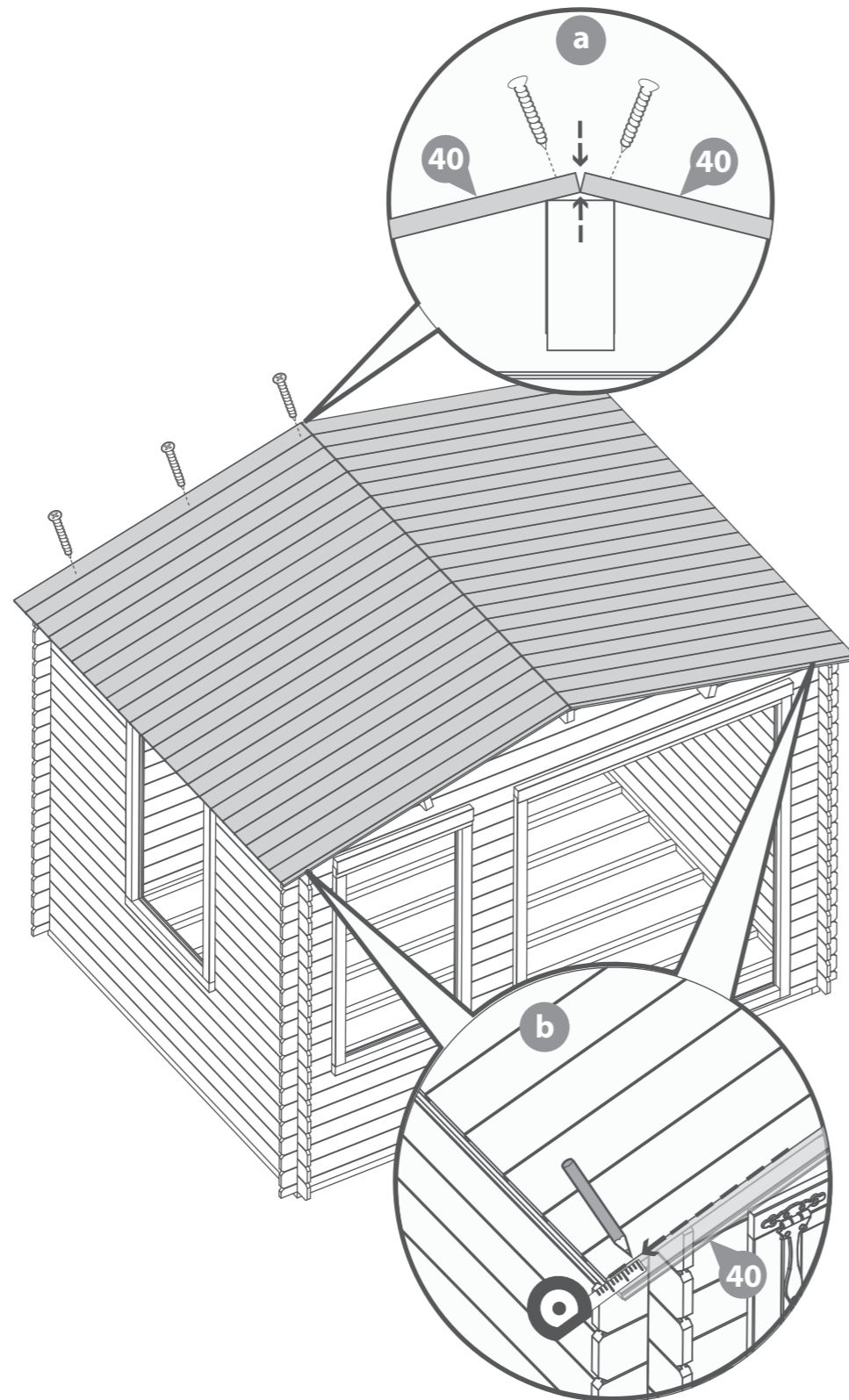

Step 15

Parts Needed - No. 36 QTY 2

Ensuring the roof boards are flush at the overhanging side and meet at the apex, fix the eaves frames (**No. 36**) to the underside of the roof boards using 9x30mm screws as shown in the illustration

***Please Note:** This image is for illustrative purposes and may differ from your choice in product. Nevertheless the process of fixing the eaves frames is the same.

18x30mm Screws



IMPORTANT: Pre-drill before fixing screws.

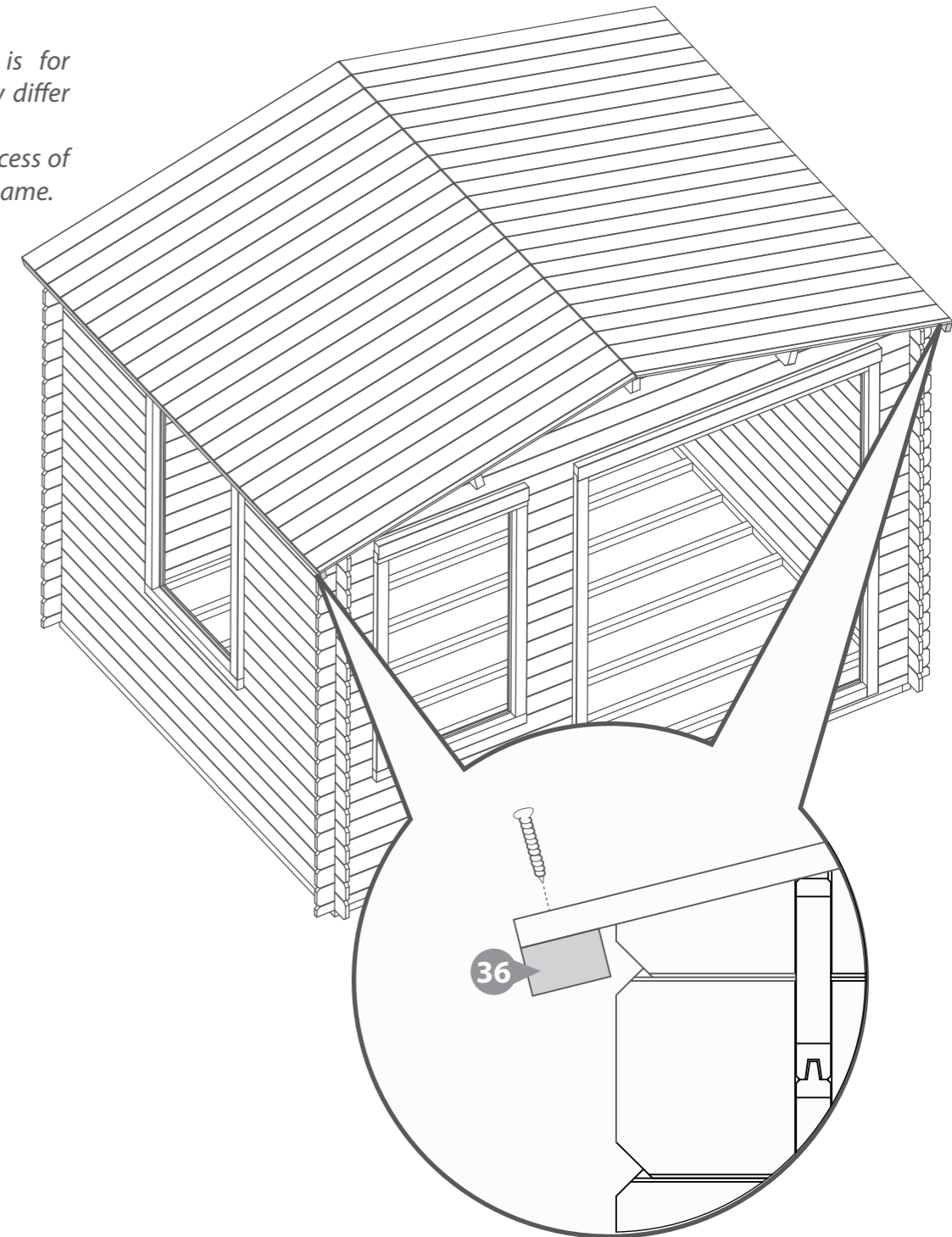

Step 16

Parts Needed - No. 1 QTY 2
No. 7 QTY 4

Place the window (**No. 1**) onto a flat surface and fix 2xT-hinges (**No. 7**) to the window using 3x30mm black screws per hinge.

Locate the window into the window frame on the cabin, ensuring there is equal spacing on each side between the window and window frame.

Secure into position by screwing through the T-hinges (**No. 7**) using 5x30mm black screws per hinge.

***Ensure to screw into the framing and not into the channel.**

Repeat this method to construct two windows.

32x30mm Black Screws

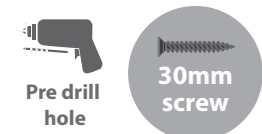

IMPORTANT : Pre-drill before fixing screws.

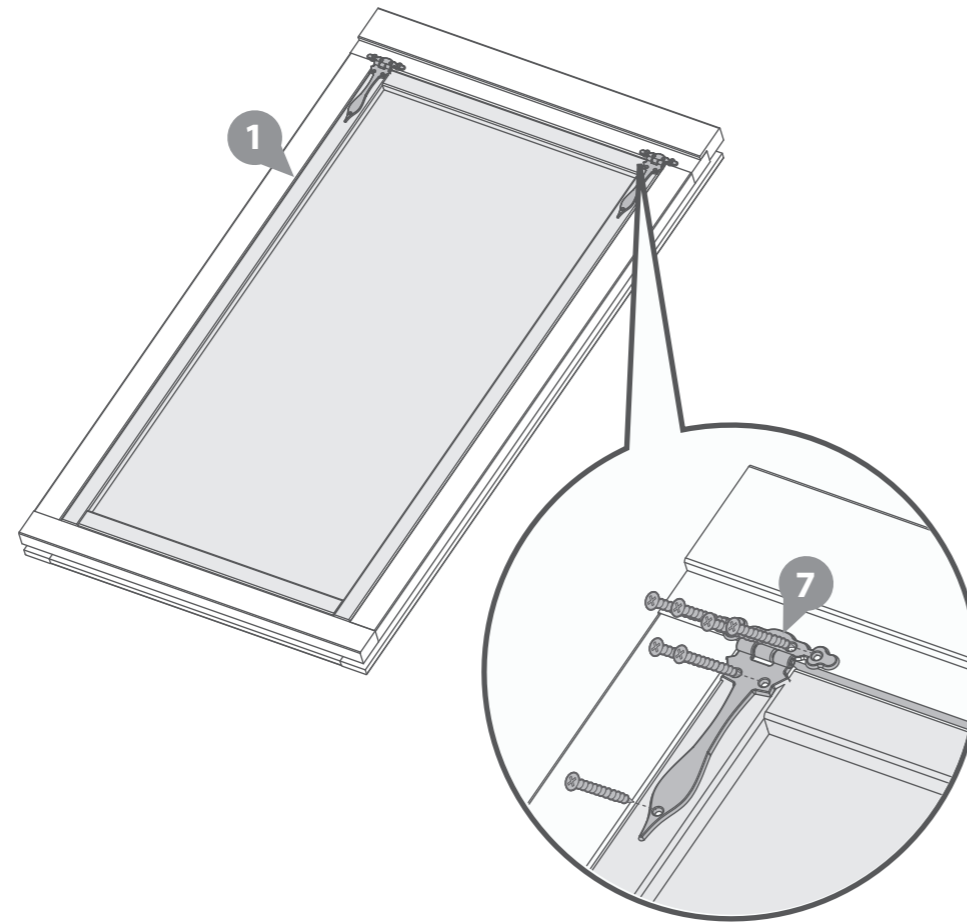

Step 18

Parts Needed - No. 9 QTY 1
No. 10 QTY 1
No. 17 QTY 6

Once the roof is fixed, place the master and slave doors (**No's 9 & 10**) onto a flat surface and fix 3x9 inch T-hinges (**No.17**) to each door using 5x30mm black screws per hinge.

Locate the doors into the door frame on the cabin, ensuring there is equal spacing on each side between the doors and door frame.

Secure into position by screwing through the T-hinges (**No.17**) using 4x30mm black screws per hinge, making sure the doors open & close freely without restriction

***Ensure to screw into the framing and not into the channel.**

54x30mm Black Screws

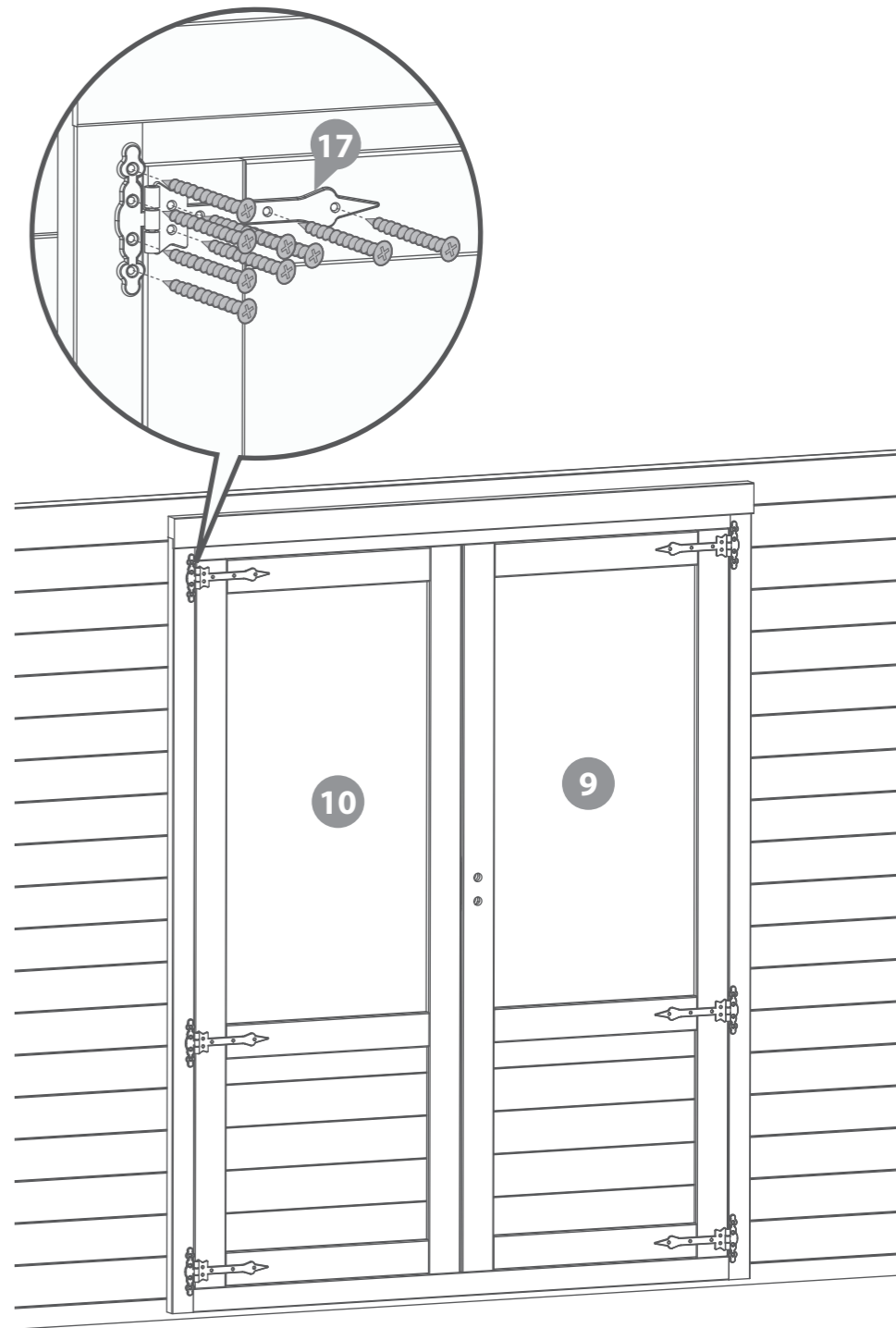

Step 17

Parts Needed - No. 8 Qty 2

Fix the casement stay (**No. 8**) onto the window (**No. 1**) and the casement stay pins to the window framing using 6x30mm black screws.

***Ensure the casement stay is centralised on the window.**

Repeat this method to fit a casement stay to both windows.

12x30mm Black Screws

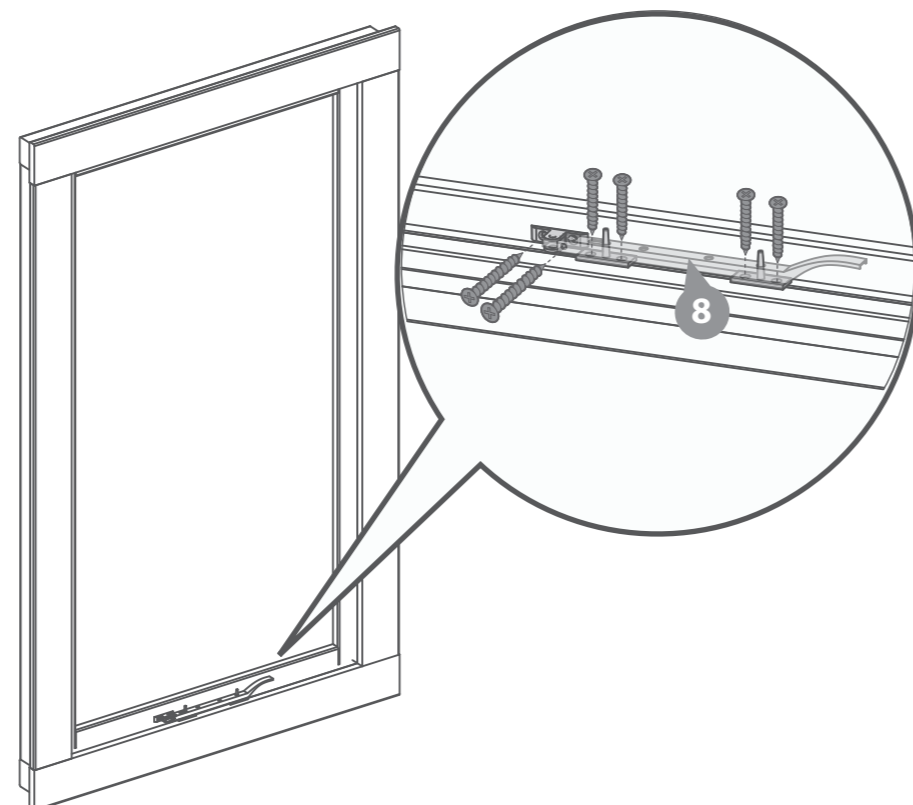

Step 19

Parts Needed - No. 18 QTY 1
 No. 19 QTY 1
 No. 20 QTY 1

a Fit the Mortice Lock (**No. 19**) into the recess in the master door (**No. 9**) and secure using the screws provided. Attach the Key Plate (**No. 20**) to the slave door (**No. 10**) with 4x30mm screws.

b Fit the Door Handles (**No. 18**) and connect with the metalbar to the mortice lock using 8x30mm black screws. Ensure the lock mechanism closes correctly. If not, remove the lock and turn the catch around using the small grub screw.

**Please note: This image is for illustrative purposes and may differ from your choice in product (regarding ironmongery). Nevertheless the process of fixing the frames is the same.*

8x30mm Black Screws
 4x30mm Screws



IMPORTANT : Pre-drill before fixing screws.

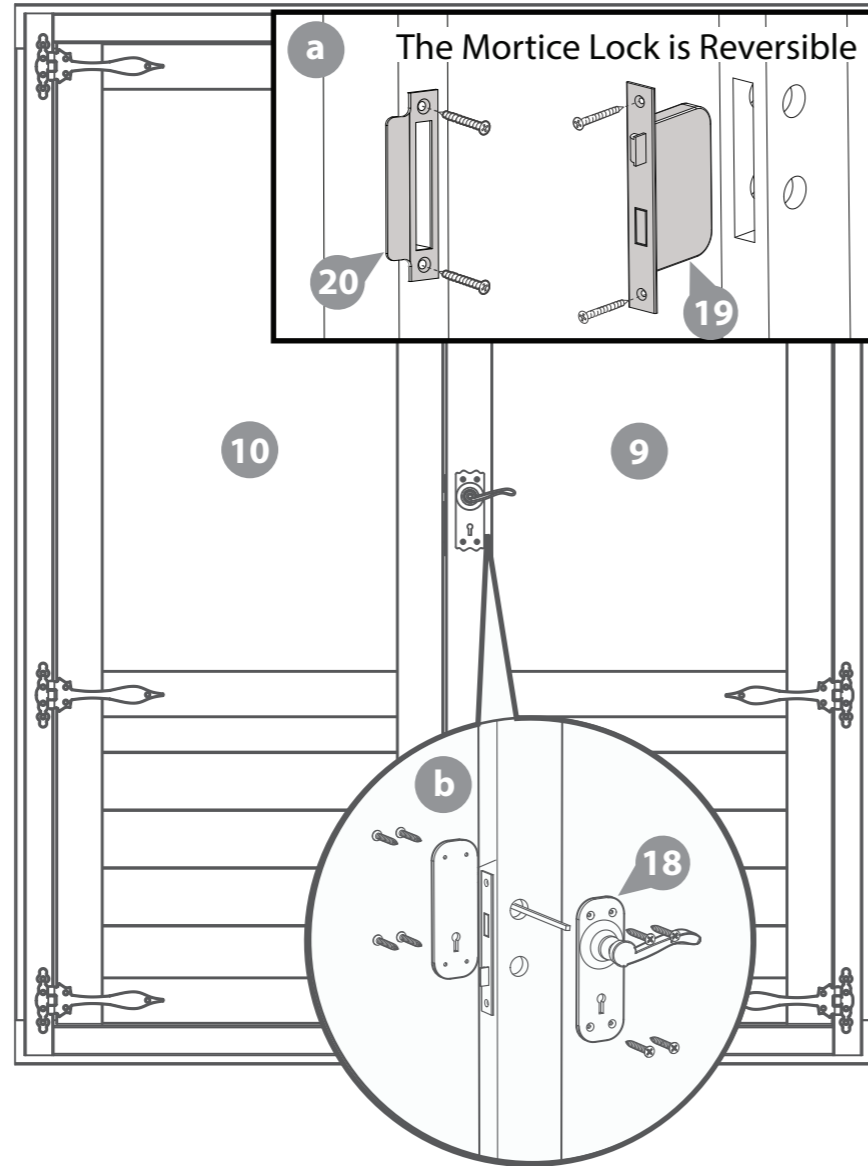

Step 20

Parts Needed - No. 15 QTY 1
 No. 21 QTY 2

Attach the Door Strip (**No. 15**) to the back of the slave door using 4x40mm screws as shown.

a Once fixed, place the Tower Bolts (**No. 21**) roughly into position at the top and bottom of the door strip. With a pencil mark the around the bolt.

b After marking the bolt onto the frame, drill a hole for the barrel bolt to locate into.

c Following the hole being drilled, place the tower bolts into position and secure using the screws provided.

4x40mm Screws

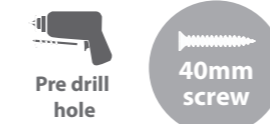

IMPORTANT : Pre-drill before fixing screws.

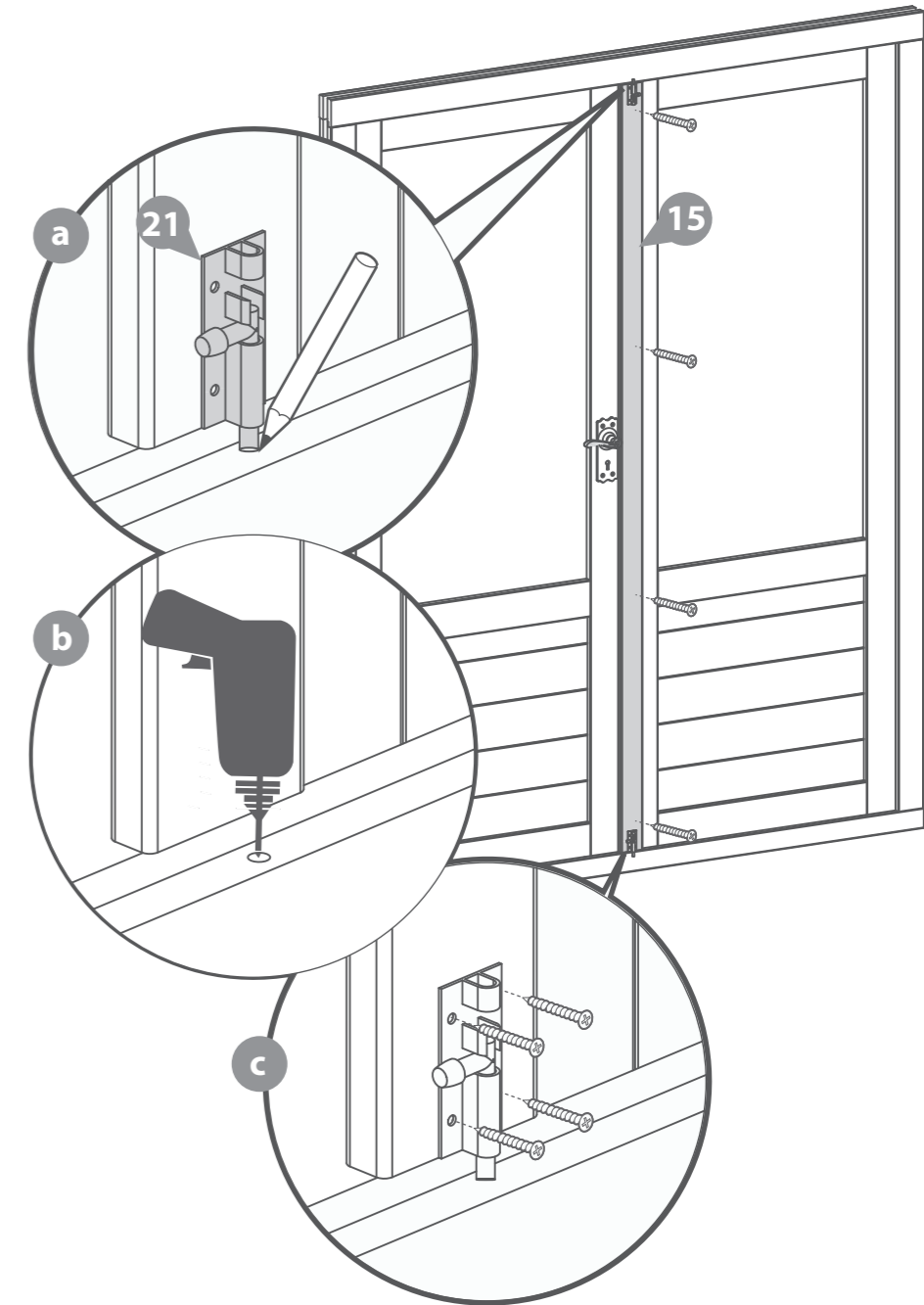

Step 21

Parts Needed - No. 39 QTY 29

Place the first floor board (No. 39) inside the building flush to the log board on one side. Continue adding the floor boards (*internally*) making sure to interlock each individual board.

You have been issued with 29 floor boards, but in reality you may only need to use 28.

***Do NOT secure the boards until the last board has been measured and cut.**

Following the same method outlined previously measure the gap between the bottom of the tongue (**on the last board placed**) and the log board.

Using a straight edge mark out the measurement onto the last floor board (No. 39) and cut along the length removing the excess.

****Please note:** Mark the final board 2mm under the measurement; This will allow the timber to expand and contract correctly.

Once all the floor boards are in position secure each board into position using 8x40mm screws.

*****Please Note:** Ensure to screw through each of the floor boards into the floor bearers.

232x40mm Screws

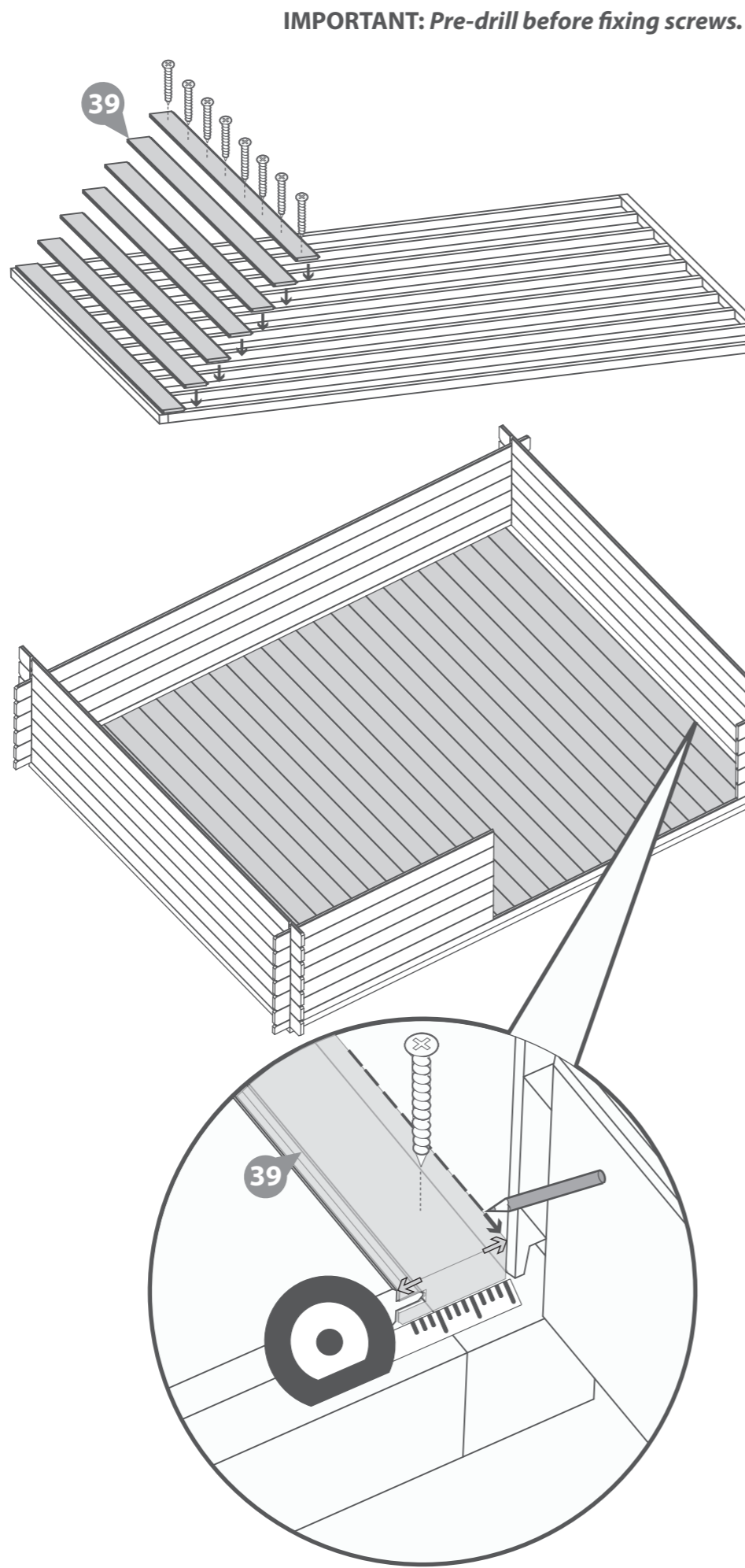
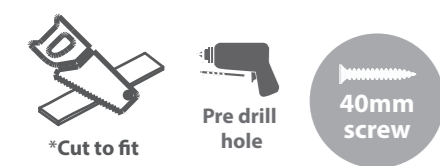

Step 22

Parts needed - No. 34 QTY 5

Inside the building place the closure trim (No. 34) against the boarding and align with the roof as shown in the illustration.

***Measure and cut the closure trims to fit the internal space.**

Once in position fix each trim into place by pre drilling a pilot hole and using 6x30mm screws per trim, equally spacing them along the face of the board.

30x30mm Screws



Step 23

Parts needed - No. 34 QTY 5

Once the floor has been laid arrange the closure trim (No. 34) around the outside edge of floor (*internally*), measure and cut down accordingly to best match the internal space.

Secure each trim section into place using 6x30mm spaced equally along the board as shown in the illustration.

***Do NOT fix the closure trim to the floor boards.**

30x30mm Screws



IMPORTANT: Pre-drill before fixing screws.

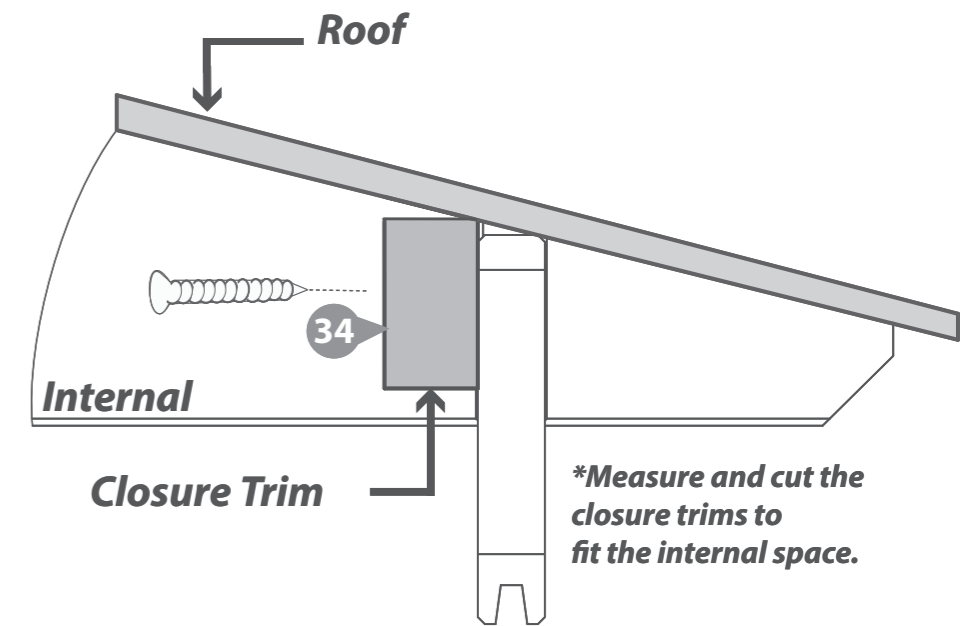

IMPORTANT: Pre-drill before fixing screws.

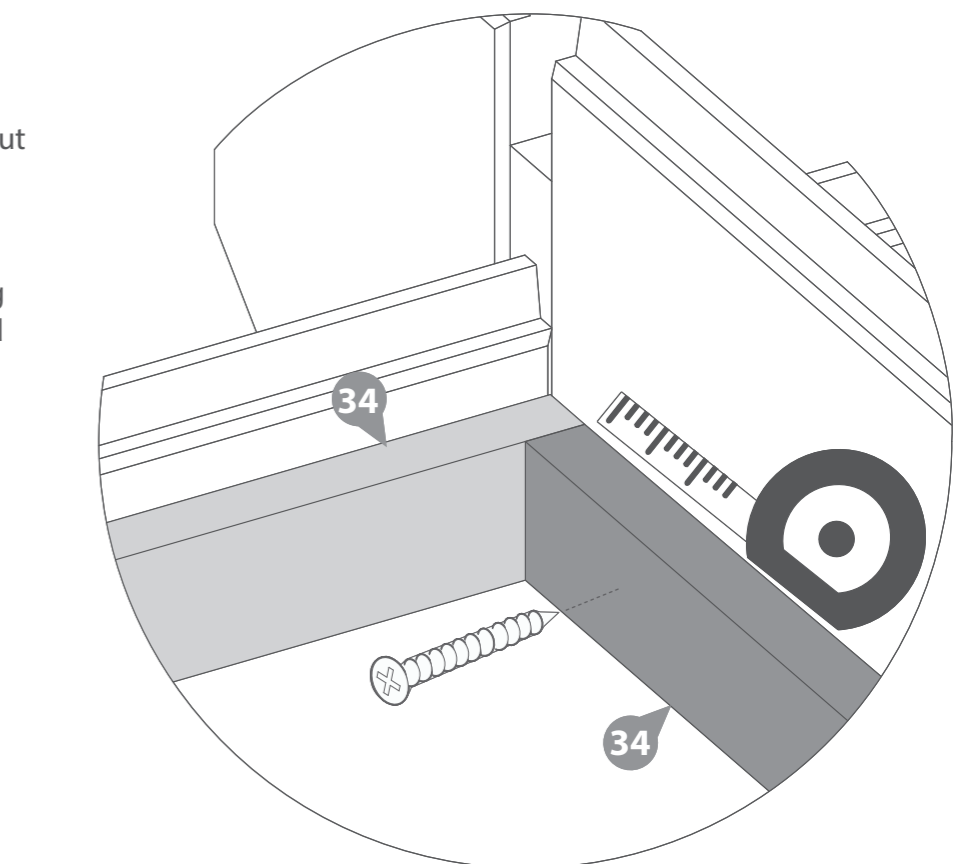

Step 24
Parts needed - No. 42

Cut the felt into five strips measuring:
2700mm (L) x 1000mm (W)
and lay onto the roof in the order shown in the illustration.

**Ensure there is approximately 50mm of overhanging felt each side.*

Once the felt is laid out fix to the roof using felt tacks at 100mm intervals.

**Felt size: 2700mm X 1000mm*

170x Felt Tacks

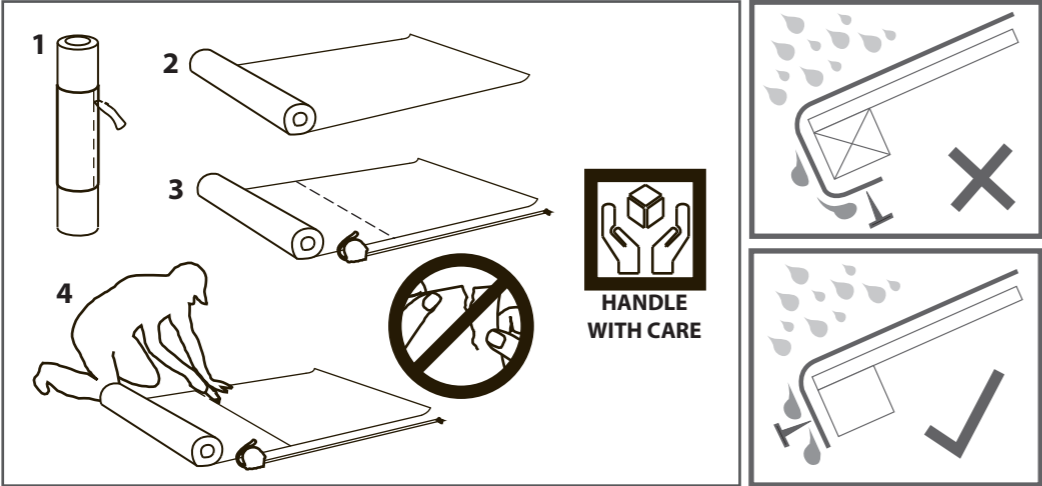
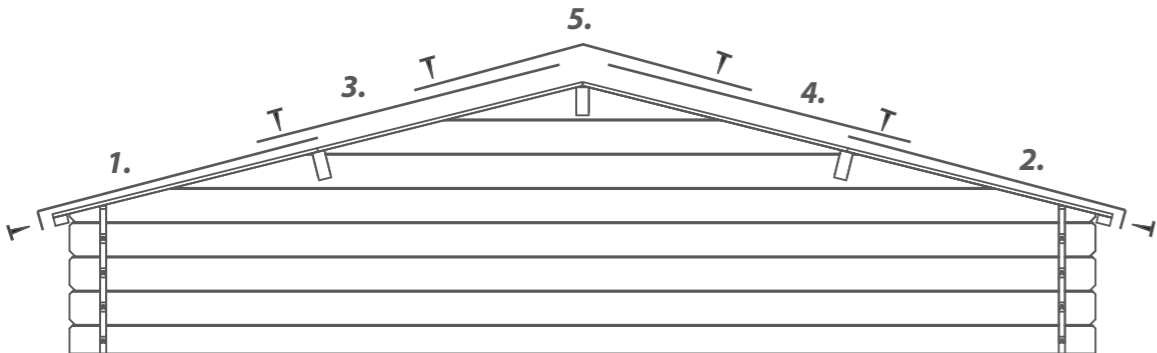
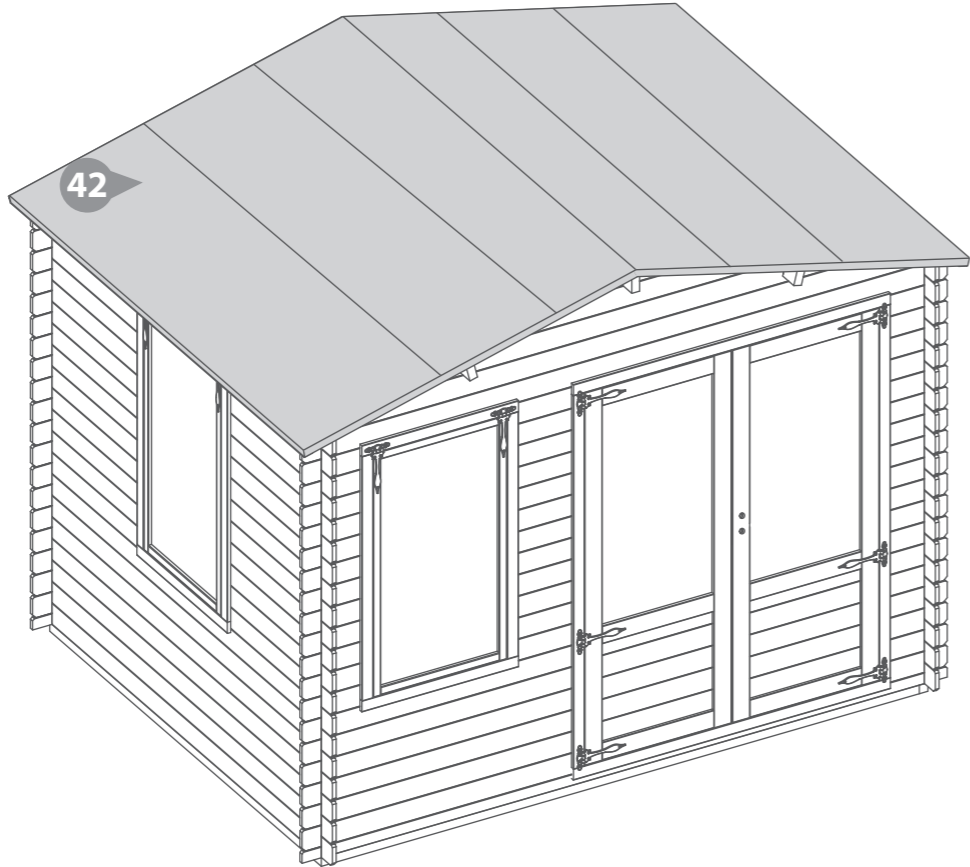

Step 25
Parts Needed - No. 35 QTY 4

Align the fascia's (**No. 35**) with the roof and fix into place using 3x40mm screws per fascia, making sure to screw through the fascia into the roof purlins and eaves frame.

**Ensure the angled cuts meet at the top of the apex.*

12x40mm Screws



IMPORTANT: Pre-drill before fixing screws.

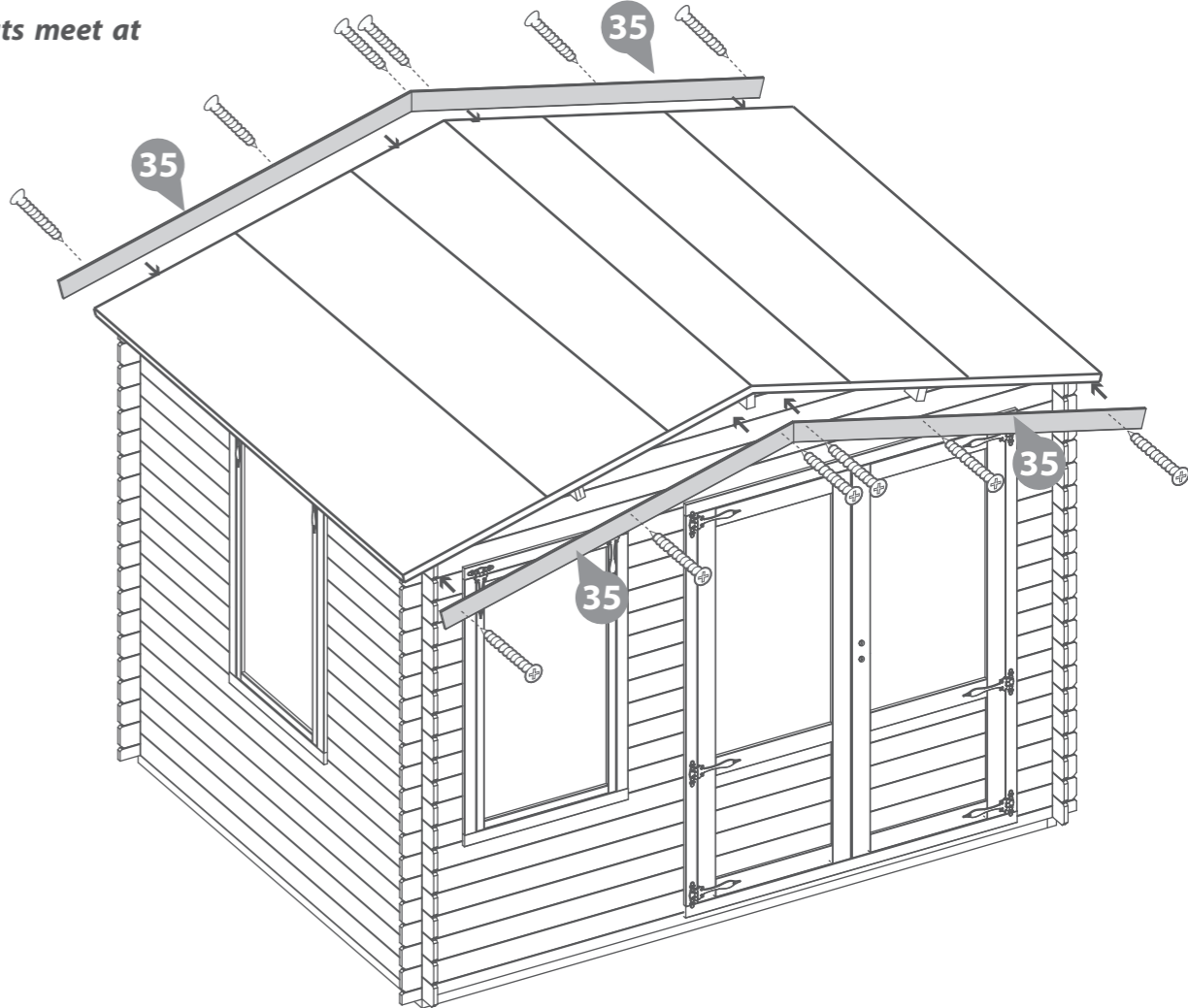

Step 26
Parts needed - No. 41 QTY 8

Arrange the storm braces (**No.41**) around the building (*internally*). Place 2x storm braces per side fixing into place using 2x 60mm bolts per brace making sure the washer & nut are tightened from the outside of the building.

The storm braces will need to be altered during the buildings life as the moisture content within the log boards changes. The boards will expand during periods of high moisture (Winter) and shrink during periods of low moisture (Summer.)

***Ensure the storm braces are secured at the highest point possible on each side.**

****Storm braces will help your building expand and contract properly.**

*****Important: Ensure each bolt is tightened using a washer so as not to damage the log boards.**

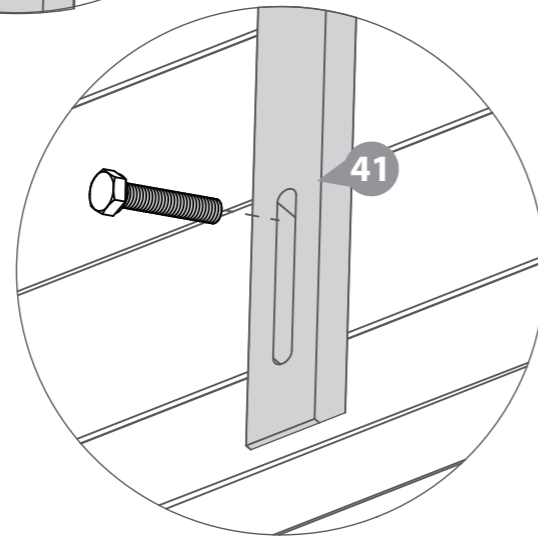
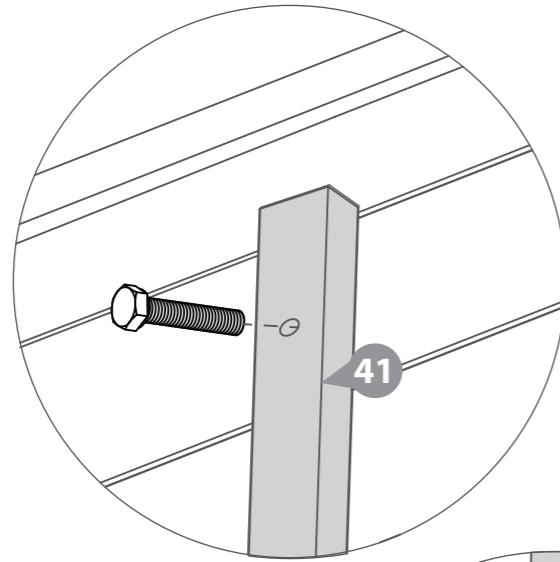

16x60mm Bolt Sets



It is **ESSENTIAL** that you apply wood treatment immediately after the building has been assembled.

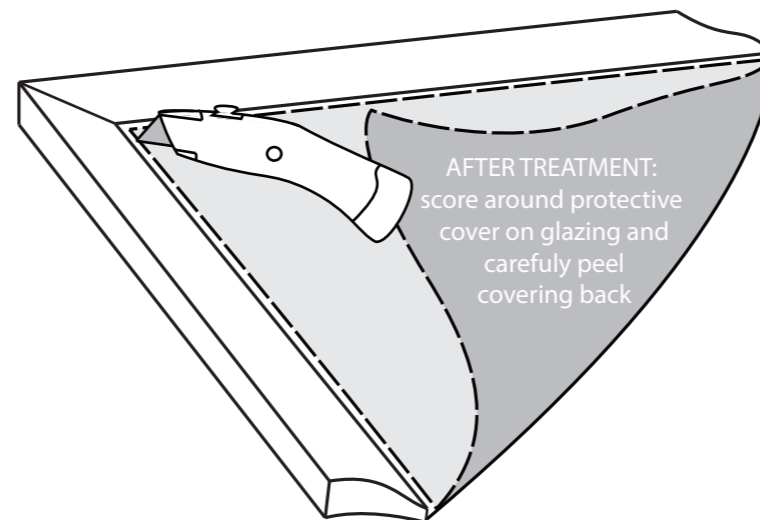

AFTER TREATMENT: score around protective cover on glazing and carefully peel covering back

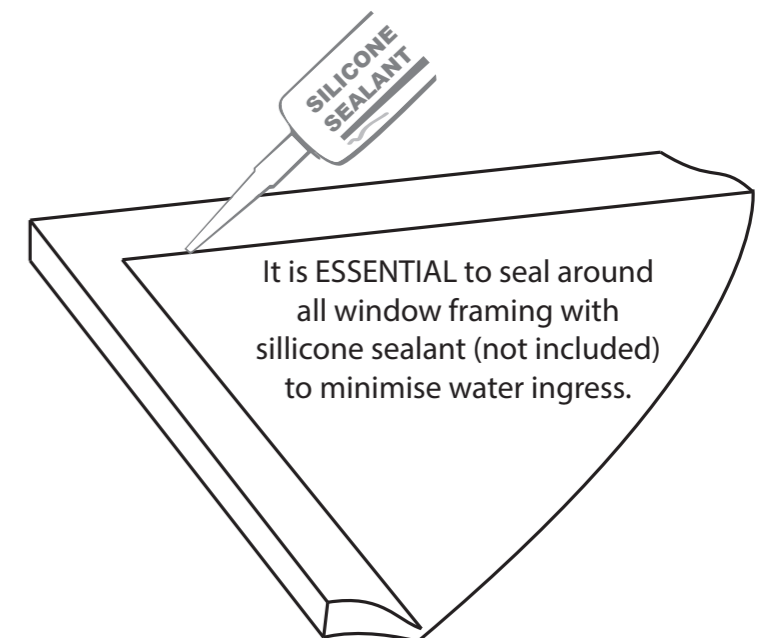

It is **ESSENTIAL** to seal around all window framing with silicone sealant (not included) to minimise water ingress.

Step 27
Parts Needed: No. 6 QTY 2
No. 16 QTY 1

Attach the Rain Guards (**No. 6**) to the Window frame, fixing in place onto the framing above each window using 3x70mm screws per guard.

Attach the Rain Guard (**No. 16**) to the Door frame, fixing in place onto the framing above the Door using 3x70mm screws.

9x70mm Screws.

