

0628CSNE0404HGDD2SW-V1

28MM LOG CABIN, CORNER STANDARD, NO EXTRAS, 4X4M, HALF GLAZED DOUBLE DOORS, TWO SHORT WINDOWS.

BEFORE YOU START PLEASE READ INSTRUCTIONS CAREFULLY

- Check the pack and make sure you have all the parts listed.
- When you are ready to start, make sure you have the right tools at hand (not supplied) including a Phillips screwdriver, Stanley knife, wood saw, step ladder and drill with 2mm bit.
- Ensure there is plenty of space and a clean dry area for assembly.

TIMBER

As with all natural materials, timber can be affected during various weather conditions. For the duration of heavy or extended periods of rain, swelling of the wood panels may occur. Warping of the wood may also occur during excessive dry spells due to an interior moisture loss. Unfortunately, these processes cannot be avoided but can be helped. It is suggested that the outdoor building is sprayed with water during extended periods of warm sunshine and sheltered as much as possible during rain or snow.

BUILDING A BASE

When thinking about where the building and base are going to be constructed: Ensure that there will be access (60cm) to all sides for maintenance work and annual treatment.

Ensure the base is level and is built on firm ground, to prevent distortion. Refer to diagrams for the base dimensions. The base should be slightly smaller than the external measurement of the building, i.e. The cladding should overlap the base, creating a run off for water. It is also recommended that the floor be at least 25mm above the surrounding ground level to avoid flooding.

TYPES OF BASE

- Concrete 75mm laid on top of 75mm hard-core.
- Slabs laid on 50mm of sharp sand.

Whilst all products manufactured are made to the highest standards of Safety and in the case of childrens products independently tested to EN71 level, we cannot accept responsibility for your safety whilst erecting or using this product.

Refer to the instructions pages for your specific product code

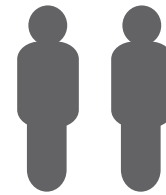

All buildings should be erected by two adults



Winter = High Moisture = Expansion
Summer = Low Moisture = Contraction

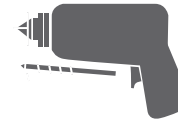

2mm Drill bit

For ease of assembly, you **MUST** pilot drill all screw holes and ensure all screw heads are countersunk.



CAUTION
Every effort has been made during the manufacturing process to eliminate the prospect of splinters on rough surfaces of the timber. You are strongly advised to wear gloves when working with or handling rough sawn timber.

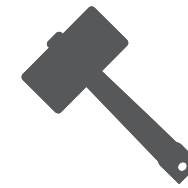

For ease of assembly use a rubber mallet to fit the log boards. Do **NOT** use a heavy hammer.



Ensure to measure and check before cutting boards.

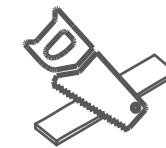

It is advisable to use a hand saw when cutting roof and floor boards.



To ensure log boards are even, use a spirit level to check each layer has been installed correctly.

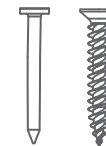

Screws & Nails

—
Measure overall length
—



Bolts

—
Measure under the head
—

To identify the fixings required for each step use a measuring tape.

For assistance please contact customer care on: 01636 821215

Mercia Garden Products Limited,
Sutton On Trent,
Newark,
Nottinghamshire,
NG23 6QN

www.merciagardenproducts.co.uk



Overall Dimensions:
 Width = 4090mm
 Depth = 4150mm
 Height = 2867mm

Base Dimensions:
 Width = 3808mm
 Depth = 3808mm

Before assembly
 please make sure you have a
 suitable base ready to erect your
 building



MADE IN GREAT BRITAIN

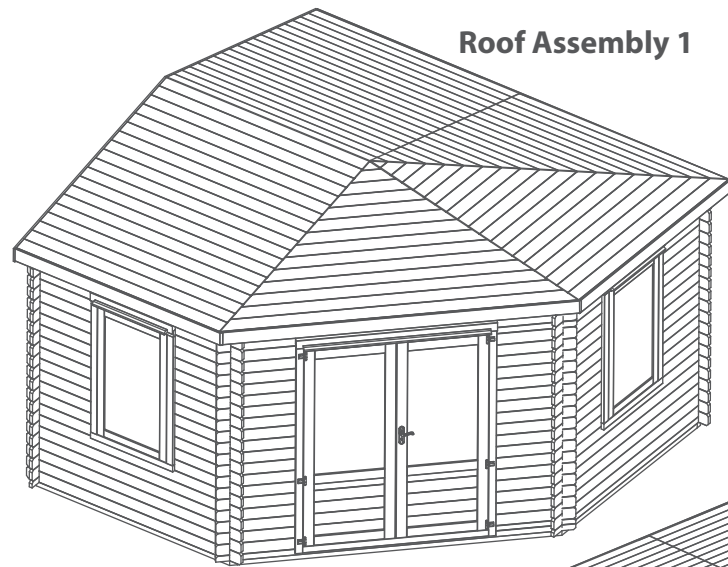

Roof Assembly 1

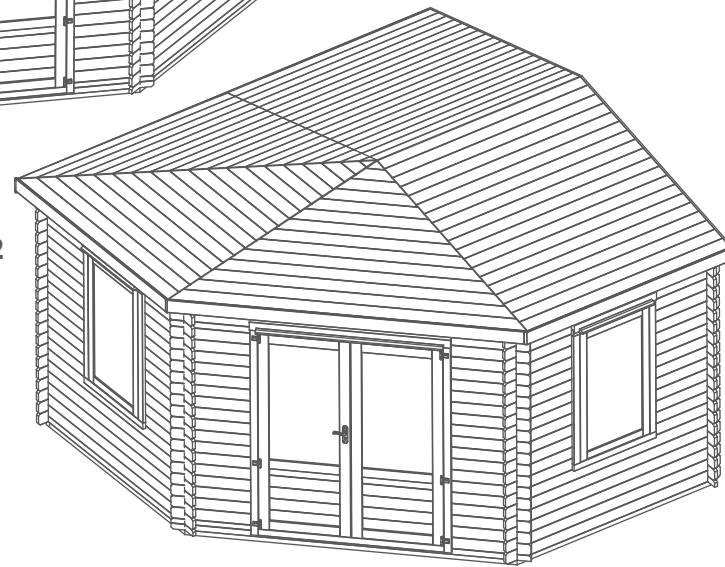

Roof Assembly 2

Double Door Contents

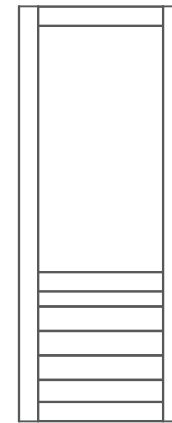

Master Door QTY 1
 (Morticed for lock)
 AI-06LOGDGM750X1900-V3

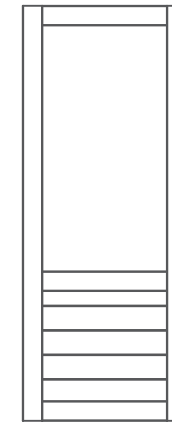

Slave Door QTY 1
 AI-06LOGDGS750X1900-V3



Door Frame Left Upright - 71x70x2065mm QTY 1
 AI-0628LOGDUFL-V3

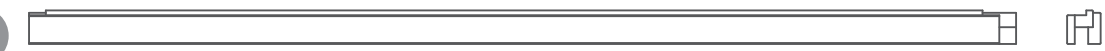

Door Frame Right Upright - 71x70x2065mm QTY 1
 AI-0628LOGDUFR-V3



Door Frame Top - 84x125x1632mm QTY 1
 AI-0628LOGDDTF-V3



Door Frame Bottom - 71x70x1508mm QTY 1
 AI-0628LOGDDBF-V3



Door Strip - 16x60x1880mm QTY 1
 S1660-1880mm

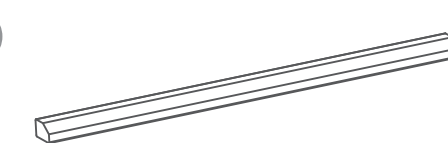

Rain Guard QTY 1
 RG2844-1520 (28x44x1520mm)



Adjustable Hinge QTY 6 PI-07-0209

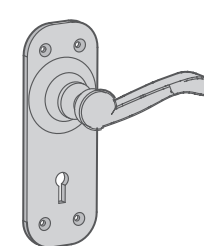
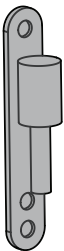
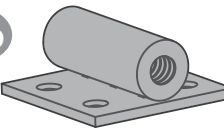
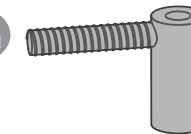

Handles (Pair) QTY 1
 PI-07-0188

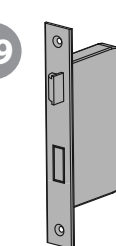

Mortice Lock QTY 1
 PI-07-0017

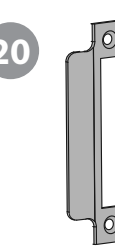

Key Plate QTY 1
 PI-07-0017

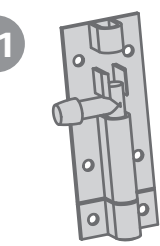

Tower Bolt QTY 2
 PI-07-0114

Window Contents

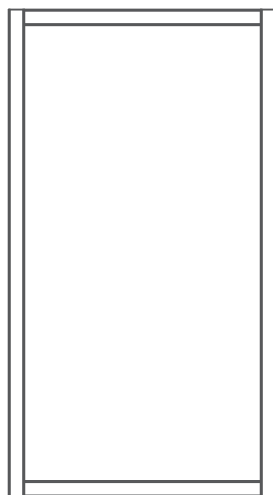

Window QTY 2
 AI-06LOGDGW684X1244-V3



Window Frame Left Upright - 71x70x1412mm QTY 2
 AI-0628LOGWUFL-V3



Window Frame Right Upright - 71x70x1412mm QTY 2
 AI-0628LOGWUFR-V3



Window Frame Top - 84x125x805mm QTY 2
 AI-0628LOGWTF-V3



Window Frame Bottom - 71x70x805mm QTY 2
 AI-0628LOGWBF-V3

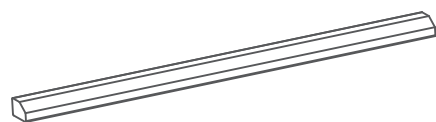

Rain Guard QTY 2
 RG2844-710 (28x44x710mm)

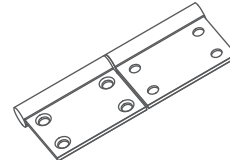

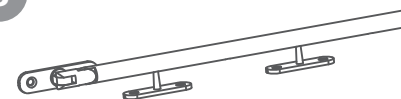

Flag Hinge QTY 4
 PI-07-0211



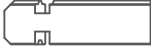

Casement Stay QTY 2
 PI-07-0187

22  **Starter Board - 28x66x2919mm QTY 1**
LB28RG66-AGRL-2919 (1x45 deg cut top, 1x45 deg cut bottom)

23  **Log Board - 28x120x675mm QTY 30**
LB28-BGL-675 (1x45 deg cut right)

24  **Log Board - 28x120x675mm QTY 29**
LB28-BGR-675 (1x45 deg cut left)

25  **Log Board - 28x60x675mm QTY 1**
LB28H60GR-675 (1x45 deg cut right, 60mm height board)

26  **Log Board - 28x70x675mm QTY 1**
LB28-H70GL-675 (1x45 deg cut right bottom notch, 70mm height board)

27  **Log Board - 28x120x2919mm QTY 1**
LB28-J-2919 (1x45 deg cut left, 1x45 deg cut right top notch)

28  **Log Board - 28x120x2919mm QTY 1**
LB28-JD-2919 (1x45 deg cut left, 1x45 deg cut right top notch, door notch)

29  **Log Board - 28x120x685mm QTY 24**
LB28-B-685

30  **Log Board - 34x66x2118mm QTY 1**
LB34RT66-AGL-2118 (1x45 deg cut left)

31  **Log Board - 28x120x2110mm QTY 7**
LB28-AGR-2110 (1x45 deg cut left)

32  **Log Board - 28x120x2110mm QTY 1**
LB28-J-2110 (1x45 deg cut left 50mm bottom notch)

33  **Log Board - 28x120x2110mm QTY 1**
LB28-JDL-2110 (1x45 deg cut left 50mm bottom notch, window notch)

34  **Log Board - 28x120x2110mm QTY 6**
LB28-AGL-2110 (1x45 deg cut right)

35  **Log Board - 28x120x2110mm QTY 1**
LB28-JDR-2118 (1x45 deg cut right, window notch)

36  **Finisher Board - 28x64x2110mm QTY 1**
LB28-AH64GR-2110 (64mm high board, 1x45 deg deep cut right)

37  **Finisher Board - 28x64x4000mm QTY 1**
LB28-AH64-4000 (64mm high board)

38  **Starter Board - 28x66x4000mm QTY 1**
LB28RT66-A-4000 (66mm high board)

39  **Log Board - 28x120x4000mm QTY 40**
LB28-A-4000

40  **Finisher Board - 28x80x885mm QTY 6**
LB28RG80-C-885

41  **Finisher Board - 28x80x1287mm QTY 1**
LB28RG80-CGR-1299 (1x45 deg cut left, 1287mm finished)

42  **Finisher Board - 28x80x1287mm QTY 1**
LB28RG80-CGL-1299 (1x45 deg cut right, 1287mm finished)

43  **Finisher Board - 28x80x920mm QTY 1**
LB28RG80-CGL-922 (1x45 deg cut left, 920mm finished)

44  **Finisher Board - 28x80x920mm QTY 1**
LB28RG80-CGR-922 (1x45 deg cut right, 920mm finished)

45  **Roof Truss A - 40x140x2113mm QTY 5**
AI-06LOGC3RTA-V1

46  **Roof Truss B - 40x140x2935mm QTY 1**
AI-06LOGC4RTB-V1

47  **Roof Truss C - 40x140x2110mm QTY 1**
AI-06LOGC4RTC-V1

48  **Roof Truss D - 40x140x2117mm QTY 1**
AI-06LOGC4RTD-V1

49  **Roof Truss E - 40x140x1540mm QTY 1**
AI-06LOGC4RTE-V1

50  **Roof Truss - 40x140x1172mm QTY 1**
AI-06LOGC4x4LRT

51  **Roof Truss - 40x140x1172mm QTY 1**
AI-06LOGC4x4RRT

52  **Roof Purlin - 45x120x2020mm QTY 1**
F45120-B-2020

53  **Bearer - 44x44x3808mm QTY 1**
F4444-3808-PT

54  **Bearer - 44x44x3720mm QTY 7**
F4444-3720-PT

55  **Bearer - 44x44x3444mm QTY 1**
F4444-G-3444-PT

56  **Bearer - 44x44x3126mm QTY 1**
F4444-G-3126-PT

57  **Bearer - 44x44x2807mm QTY 1**
F4444-G-2807-PT

58  **Bearer - 44x44x2489mm QTY 1**
F4444-G-2489-PT

59  **Bearer - 44x44x2135mm QTY 1**
F4444-G-2135-PT

60  **Bearer - 44x44x1947mm QTY 1**
F4444-G-1947-PT

61  **Bearer - 44x44x1903mm QTY 1**
F4444-G-1903-PT

62  **Bearer - 44x44x2658mm QTY 1**
F4444-G-2658-PT



63

Fascia - 16x120x4100mm QTY 1
SR16120-4100

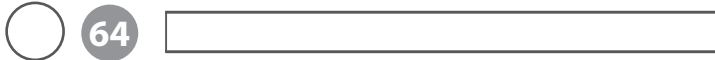

64

Fascia - 16x120x3000mm QTY 1
SR16120-3000



65

Fascia - 16x120x2500mm QTY 2
SR16120-2500



66

Fascia - 16x120x2168mm QTY 2
S16120-G-2168 (2x14 deg cuts, length 2168)

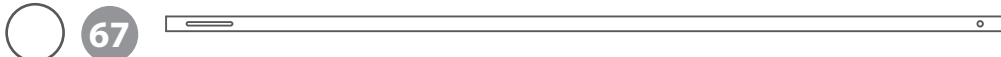

67

Storm Brace - 27x44x2000mm QTY 10
F2744-2000mm



68

Closure Trim - 16x28x2400mm (approx length) QTY 14
S1628-2400



69

Felt



70

Roof Spacers QTY 5
PI-07-0208 (20x100x2mm)



71

Floor Board Pack
AI-0628CSNE0404HGDD2SW-FBP-V1



72

Roof Board Pack A QTY 2
AI-06LOGC4X4RBP1-V5



73

Roof Board Pack B QTY 2
AI-06LOGC4X4RBP2-V5

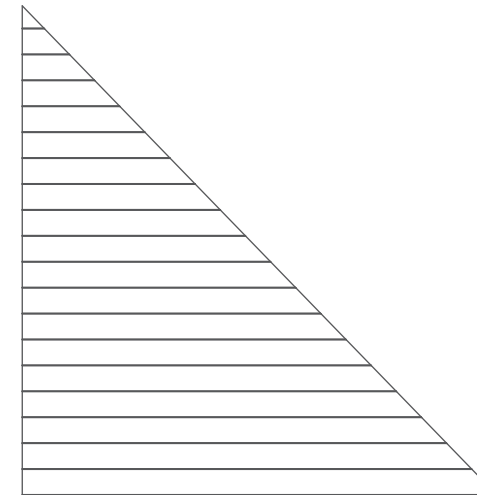

74

Roof Board Pack C QTY 1
AI-06LOGC4X4RBP3-V5

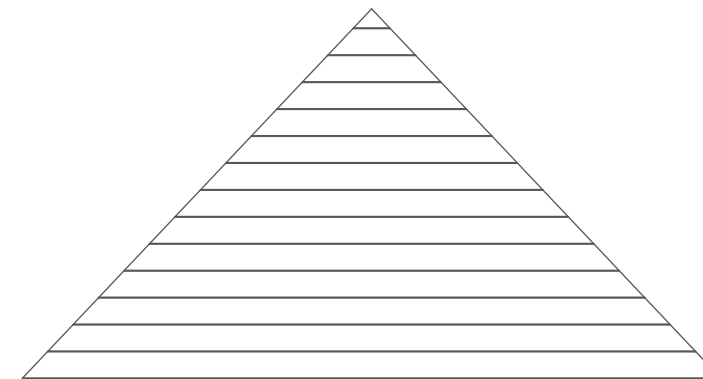

75

Gable QTY 1
AI-0628LOGC4-G-V1

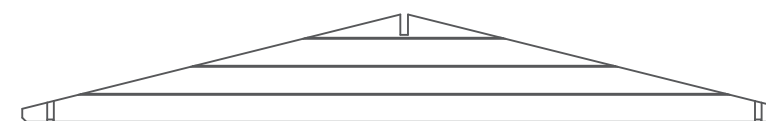

***HINT: keep the roof board packs separate to prevent mixing them up.**

***HINT: keep the roof board packs separate to prevent mixing them up.**

***HINT: keep the roof board packs separate to prevent mixing them up.**

Nail Bag

There may be extra screws present in the nail bag

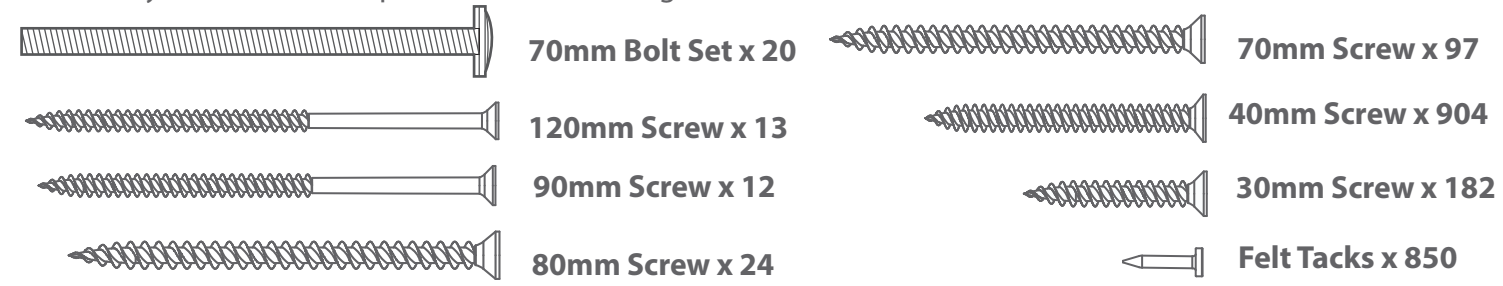

Pre-assembly

***Please note:**

Each board interlocks at either end in a staggered pattern.

Before securing ensure that the boards are fitted properly in their respective tongues and grooves.

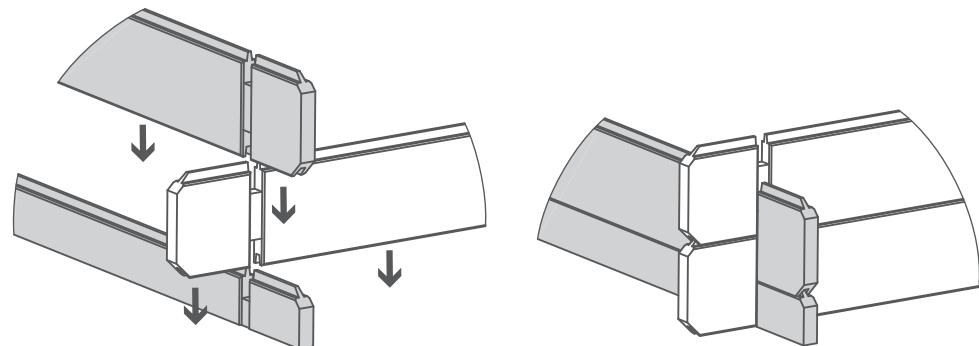

Step 1

- Parts needed - No. 53 QTY 1
 No. 54 QTY 1
 No. 60 QTY 1
 No. 61 QTY 1
 No. 62 QTY 1

Lay the bearers (No. 53, 54, 60, 61 & 62) onto a firm and level surface (free from areas where standing water can collect) as shown in the illustration.

Fix the bearers together at each corner using 10x70mm screws, ensuring the frame is flush.

Once fully assembled, ensure the bearers are square by measuring from corner to corner, as illustrate, making sure they are an equal measurement.

If the bearers are not alligned equally, unscrew and adjust and re-align accordingly.

10x70mm Screws



Pre drill hole



70mm screw

IMPORTANT: Pre-drill before fixing screws.

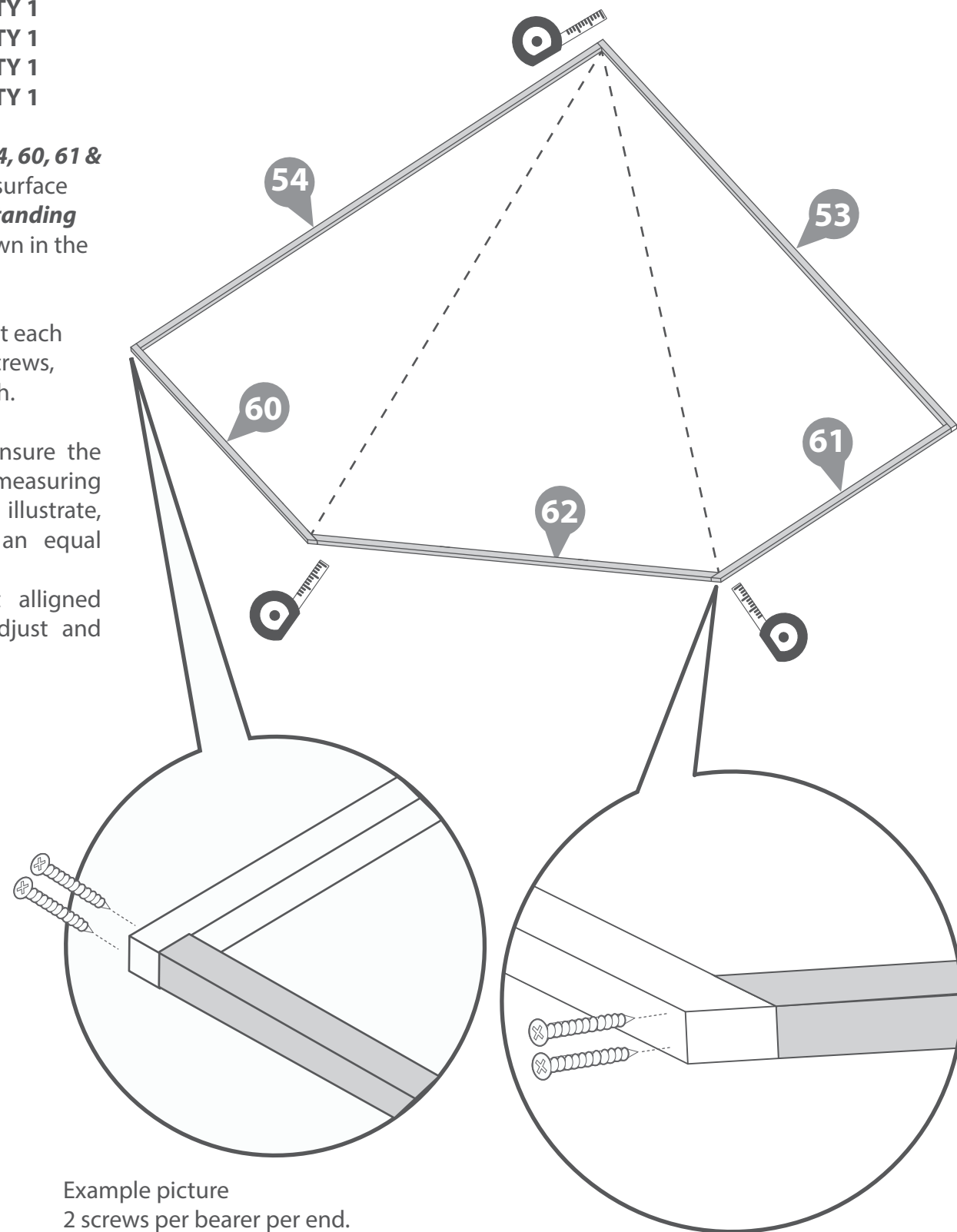

Example picture
2 screws per bearer per end.

Step 2

- Parts needed - No. 54 QTY 6
 No. 55 QTY 1
 No. 56 QTY 1
 No. 57 QTY 1
 No. 58 QTY 1
 No. 59 QTY 1

Arrange the remaining framing (No. 54, 55, 56, 57, 58 & 59) as shown in the illustration.

***Ensure there is an equal amount of space between each frame.**

Check the assembled bearers sit square using the same method used in Step 1.

Secure each of the frames in place using 2x70mm screws for each side of the bearer, ensuring the bearing remains level.

44x70mm Screws



Pre drill hole



70mm screw

IMPORTANT: Pre-drill before fixing screws.

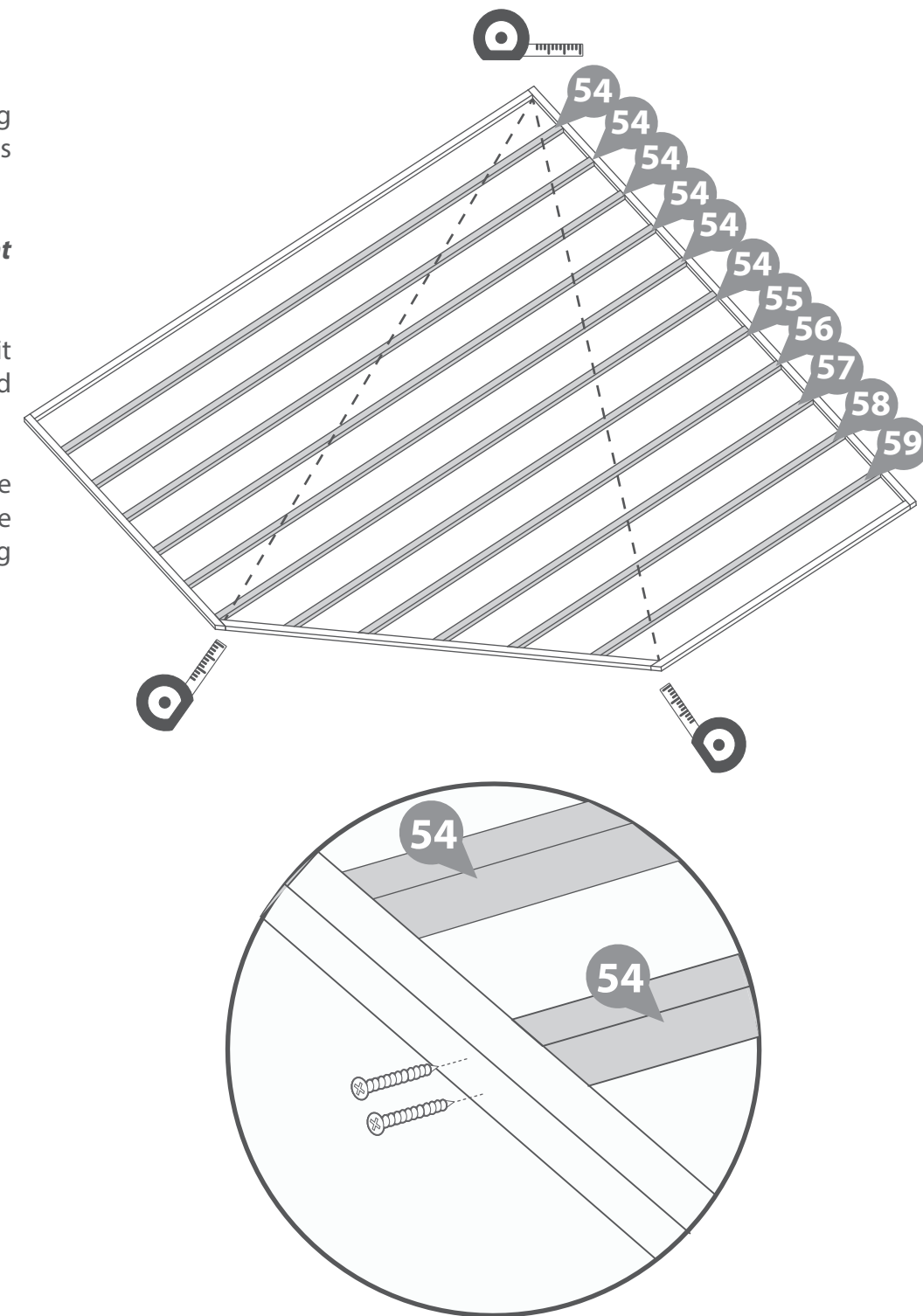

Step 3

- Parts Needed - No. 22 QTY 1**
No. 30 QTY 1
No. 31 QTY 1
No. 38 QTY 1
No. 39 QTY 1

IMPORTANT: Pre-drill before fixing screws.

Place the starter boards (**No. 22, 30 & 38**) onto the assembled base frame and place the first two log boards (**No.31 & 39**) sitting in the notch as shown.

Ensure the boards sit square on the base using the same method used in Step 1. Measure from corner to corner and ensure they are equal in measurement.

Once the boards are square, fix the starter boards (**No. 22, 30 & 38**) in place, lift up the log boards (**No.31 & 39**) and fix each starter board in place.

Fix each of the starter boards to the frame by screwing through the notch into the frame with 1x70mm screw as shown in the illustration.

5x70mm Screws

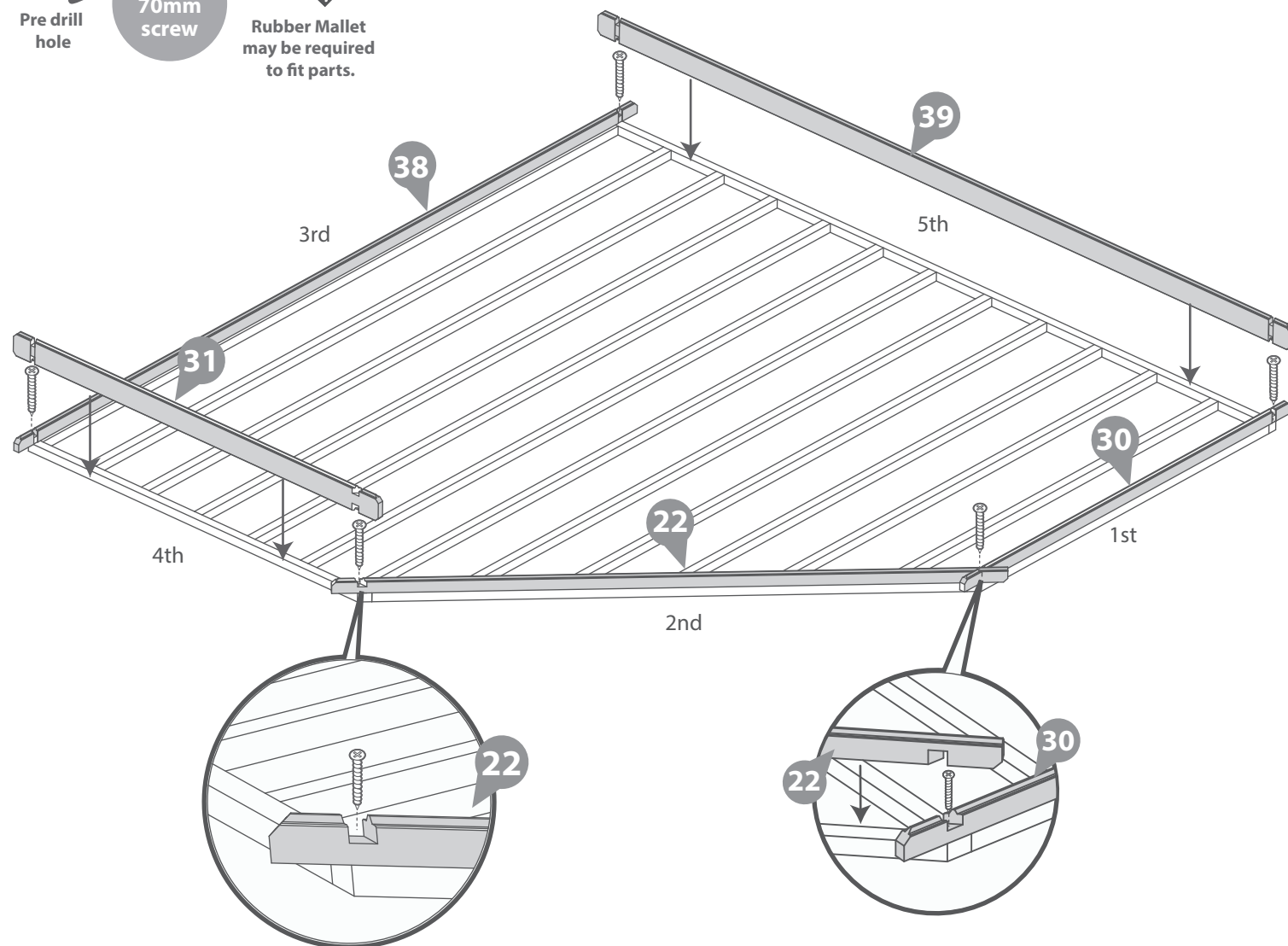
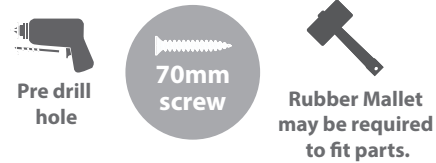

Step 4

- Parts needed - No. 25 QTY 1**

Make the assembly level by adding another board (**No.25**) as shown in the diagram. Fix using 1x70mm screw.

****Ensure to stagger the screws so as not to collide with the previous screw.**

1x70mm Screws

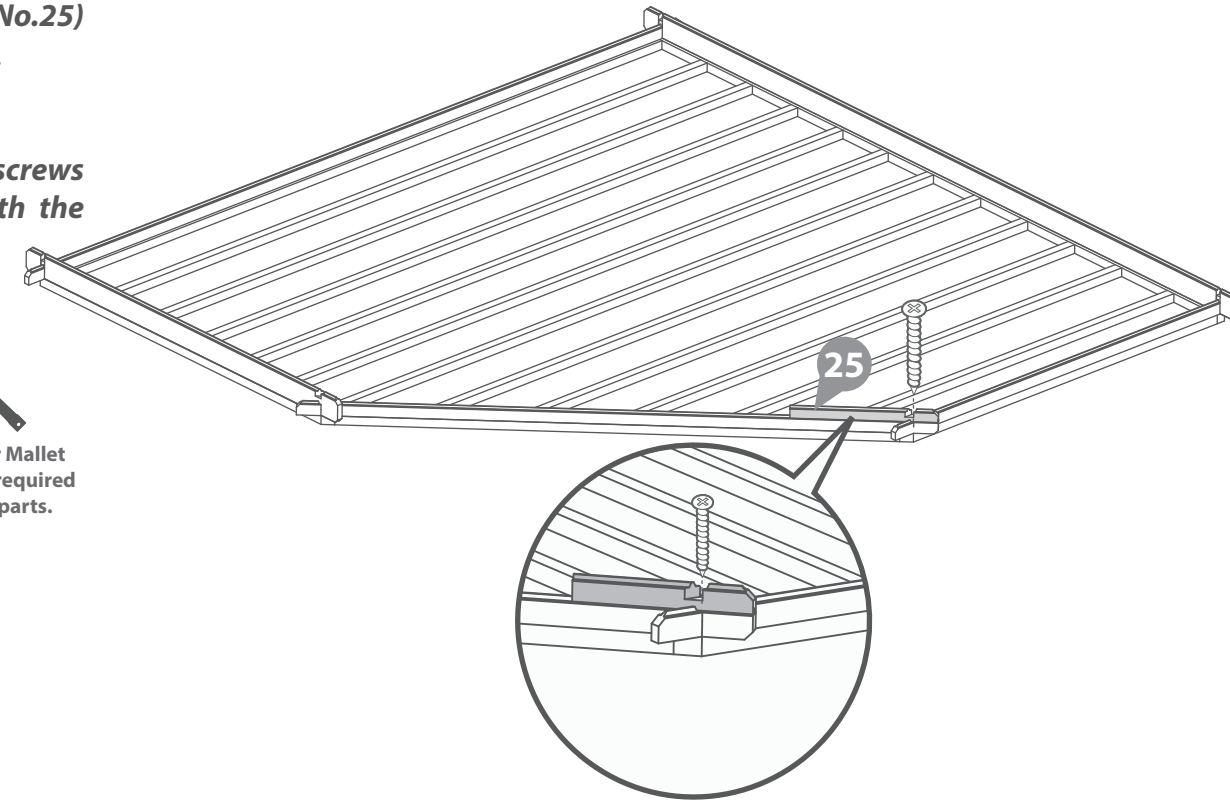
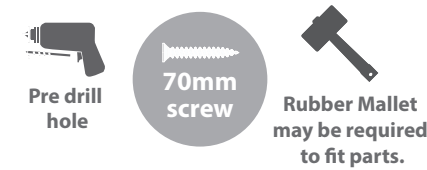

Step 5

- Parts needed - No. 23 QTY 6**
No. 24 QTY 6
No. 31 QTY 5
No. 34 QTY 6
No. 39 QTY 11

Lay the first 6 boards (**No. 23, 24, 31, 34 & 39**) onto the starter boards to create your first level, following the method as shown in the illustration.

Please note the right hand side of the door will be slightly higher. This will even out when the rest has been assembled.

***Ensure that the boards are level and flush with each other as you lay each one.**

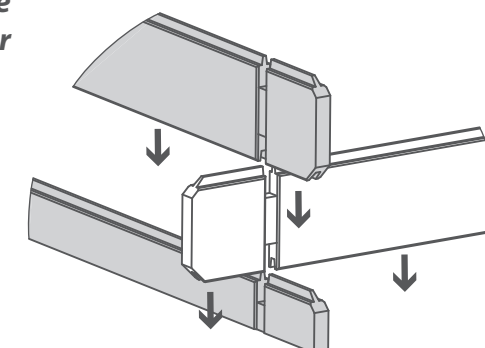
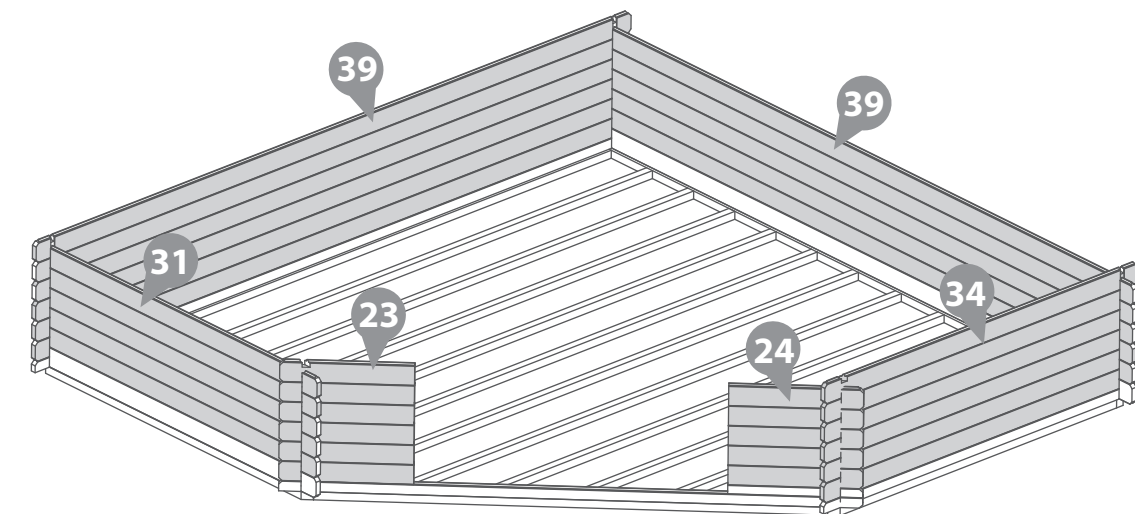

Step 6

- Parts Needed - No. 11 QTY 1**
No. 12 QTY 1
No. 13 QTY 1
No. 14 QTY 1

IMPORTANT : Pre-drill before fixing screws.

Arrange the left, right, top & bottom door frames (**No's. 11, 12, 13 & 14**) onto a level surface. Secure the top and bottom frames to the uprights using 2x80mm screw per corner, ensuring the screws do **NOT** protrude through the front of the door framing.

8x80mm Screws

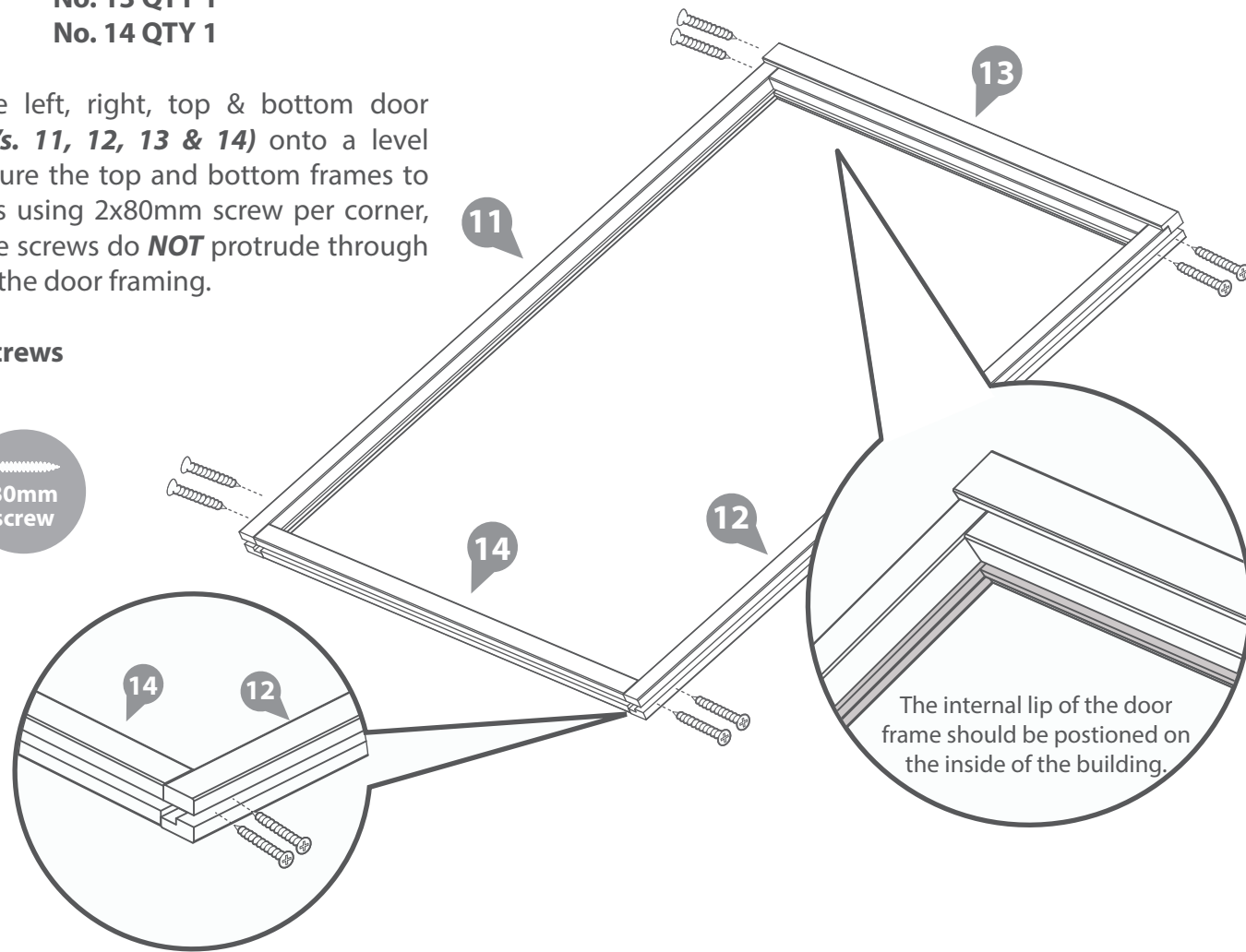
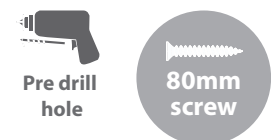

Step 7

- Parts Needed - No. 9 QTY 1**
No. 10 QTY 1
No. 17 QTY 6

IMPORTANT : Pre-drill before fixing screws.

a The Adjustable Door Hinge (**No.17**) comes in three parts.

Fasten No. 17a into 17b as shown in the illustration.

b Place the master and slave doors (**No's 9 & 10**) onto a flat surface and fix the Adjustable door hinge (**No.17c**) to the doors using 3x30mm screws per hinge.

Fix 3 x Adjustable Door Hinges (**No. 17a & b**) into position onto the door frame using 4x30mm screws per hinge.

***Ensure the hinges are fitted to the external of the door frame so the doors open outwards from the log cabin.**

Locate the doors into the hinges ensuring there is equal spacing on each side between the doors and door frame, and that the doors open & close freely without restriction.

It is important to fit the doors within the frames at this stage so that you can establish the position of the hinges. The hinges come in three parts. Remove the doors from the frame after fitting.

****Ensure to screw into the framing and not into the channel.**

42x30mm Screws

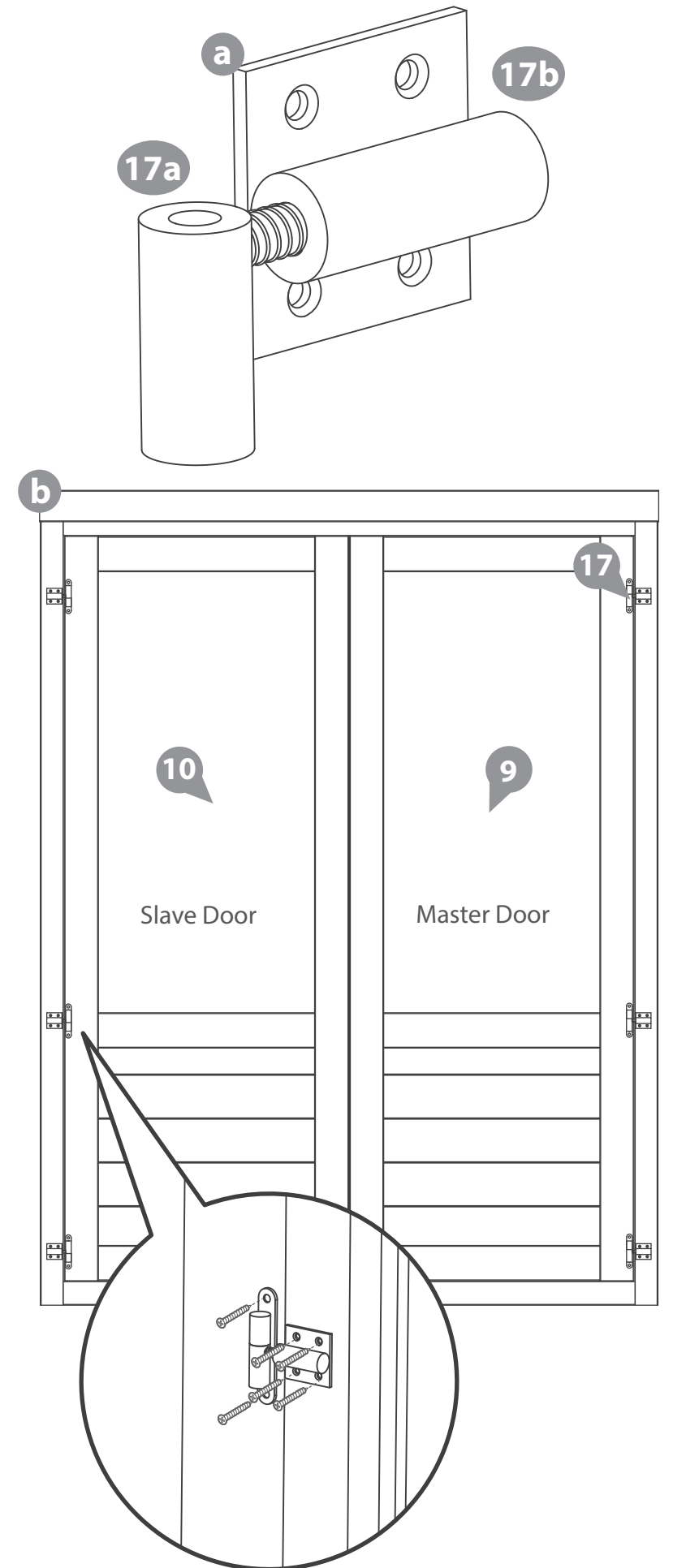

Step 8

To adjust and align your doors:

1. Lift up the doors to separate the two parts of the hinge.
2. Turn the rotating barrel (No.17a) in / out to move the position of the doors either in or away from each other.
3. You can then place the door(s) back on to the hinge and check the whether they require more / less adjustments, if further adjustments are required repeat number 2.

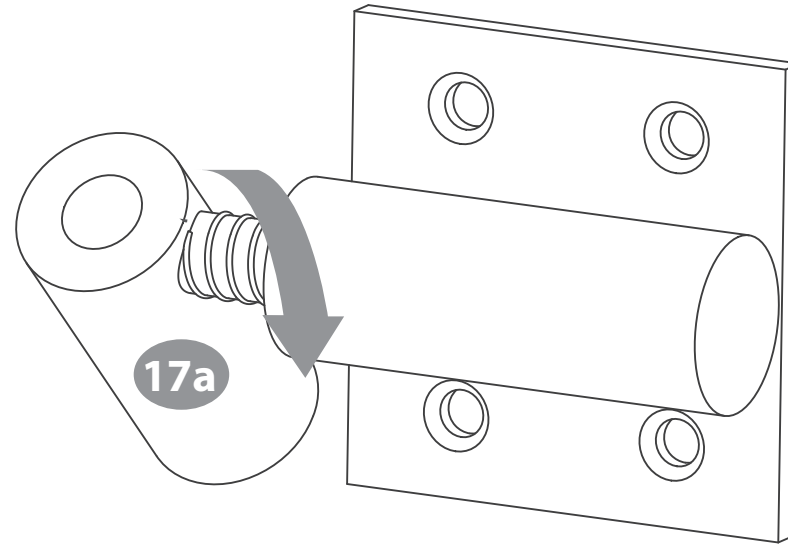

Step 10

- Parts needed - No. 23 QTY 12
 No. 24 QTY 12
 No. 29 QTY 12
 No. 39 QTY 12

Following the method as shown in the illustration, lay the next 6 boards (No. 23, 24, 29 & 39) onto the log cabin to create your second level.

***Ensure that the boards are level and flush with each other as you lay each one.**

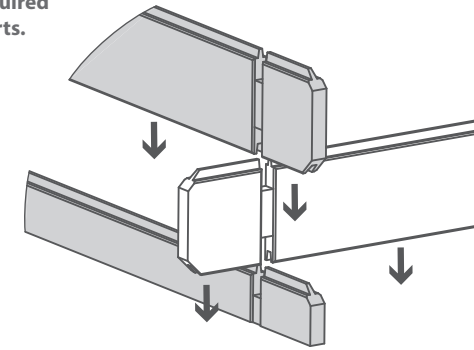
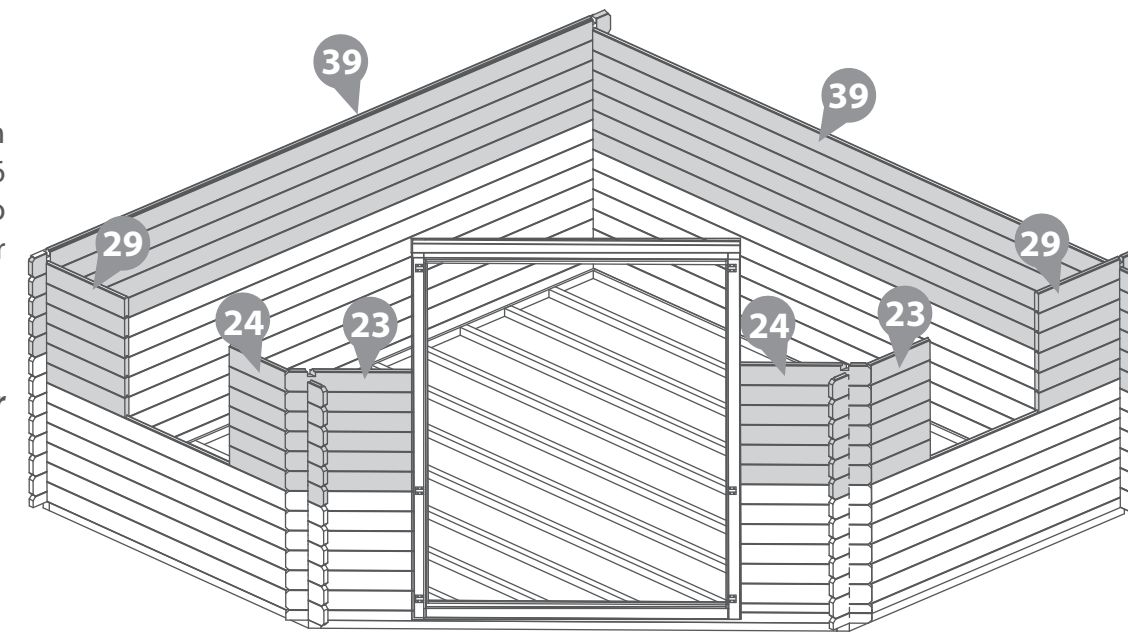

Step 9

Once you have laid 6 log boards (off of the starter) up the door section, slide the assembled door frame over the boards resting the frame on top of the starter board (if you have not yet assembled the door frame refer to step 6)

***Please note:** This image is for illustrative purposes and may differ from your choice in product (regarding door position). Nevertheless the process of fitting the door frame is the same.

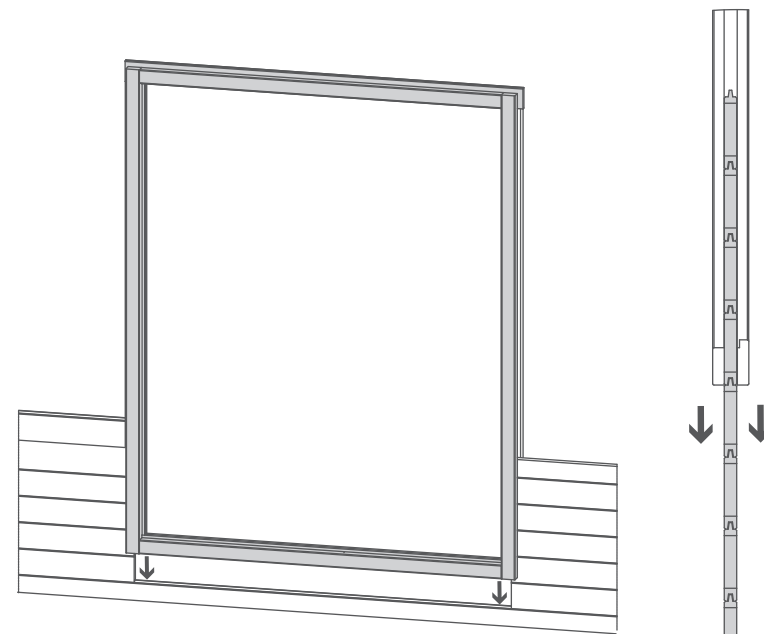

Step 11

- Parts Needed - No. 2 QTY 2**
No. 3 QTY 2
No. 4 QTY 2
No. 5 QTY 2

Arrange the left, right, top & bottom window frames (**No's. 2, 3, 4, & 5**) onto a firm and level surface. Secure the top and bottom frames to the uprights using 2x80mm screw per corner, ensuring the screws do **NOT** protrude through the front of the window framing.

Use this method to construct 2 window frames.

16x80mm Screws

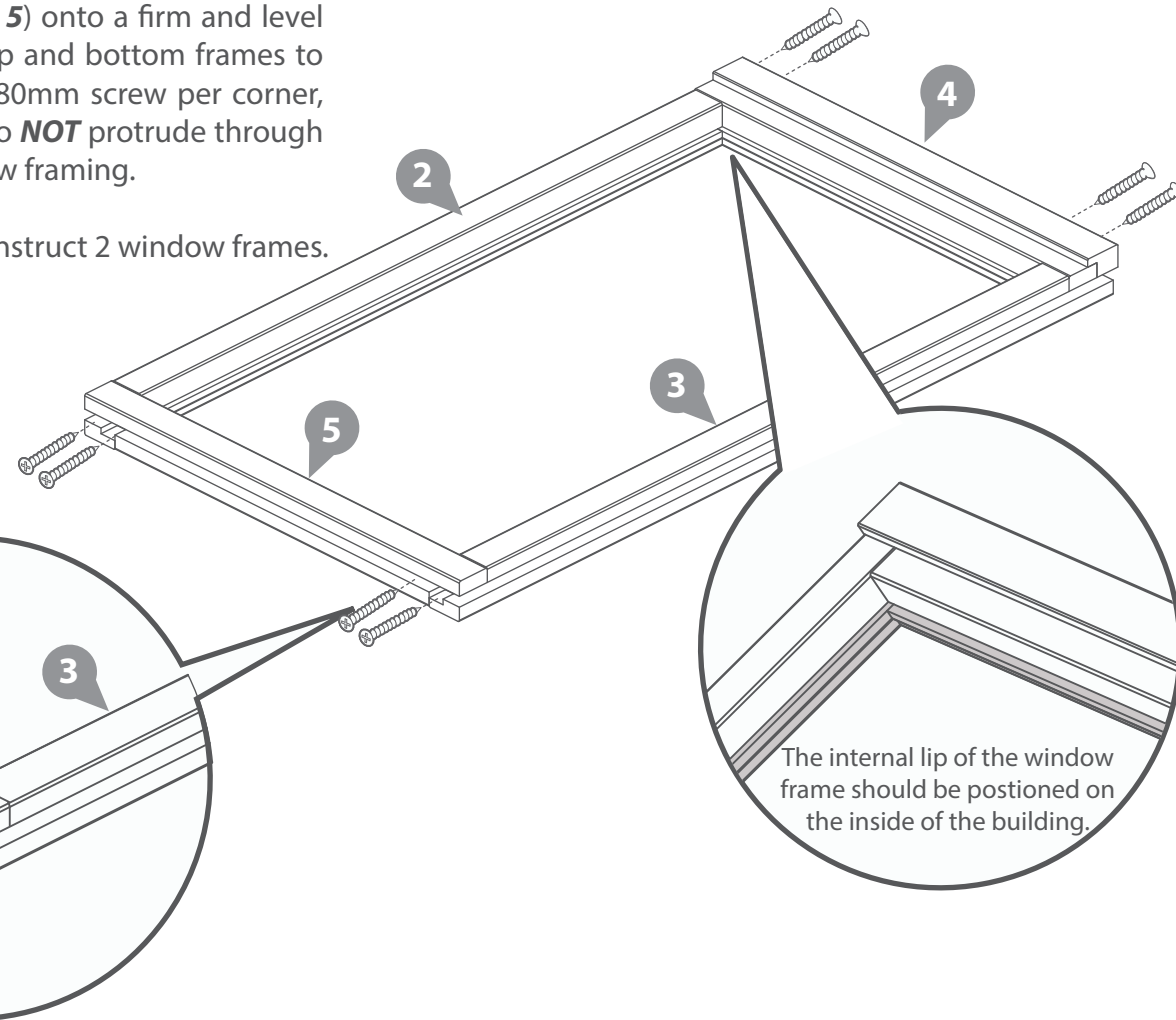

IMPORTANT : Pre-drill before fixing screws.

Step 12

- Parts Needed - No. 1 QTY 2**
No. 7 QTY 4

Position the window (**No. 1**) so that it sits centrally within the window frame. Fix the female part of the flag hinge (**No. 7**) to the window using 4x30mm screws, attach the male part of the flag hinge (**No. 7**) to the window frame using 4x30mm screws ensuring that the window can open and close freely.

Ensure to attach the hinge to the horizontal frame of the window

Repeat this method for both windows

****It is important to fit the windows within the frame at this stage so that you can establish the position of the hinges. The hinges come in two parts. Remove the window from the frame after fitting.**

32x30mm Screws

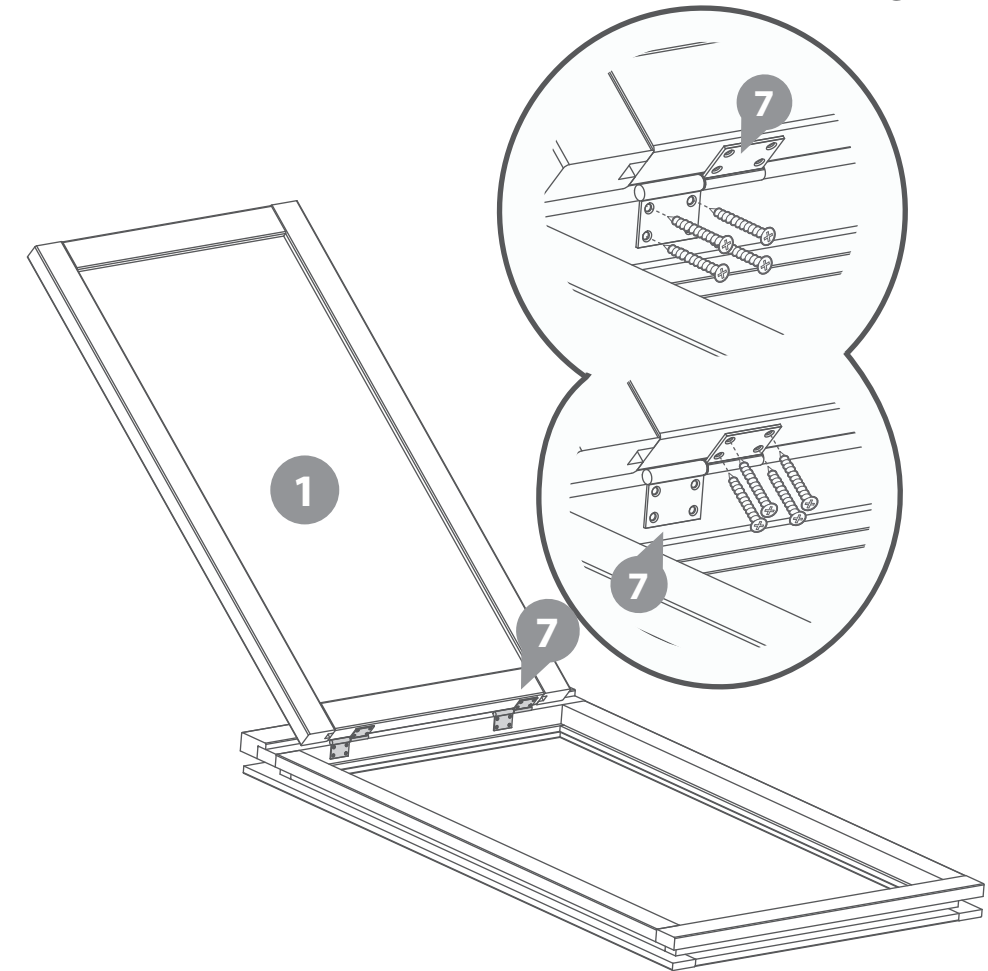

IMPORTANT: Pre-drill before fixing screws.

Step 13

Once you have laid the second level of boards onto the log cabin slide the windows between the smaller boards and rest on to the longer board (**if you have not yet assembled the window frames refer to step 11**)

***Ensure the boards are level with each end.**

***Please note:** This image is for illustrative purposes and may differ from your choice in product (**regarding window position**). Nevertheless the process of fitting the window is the same

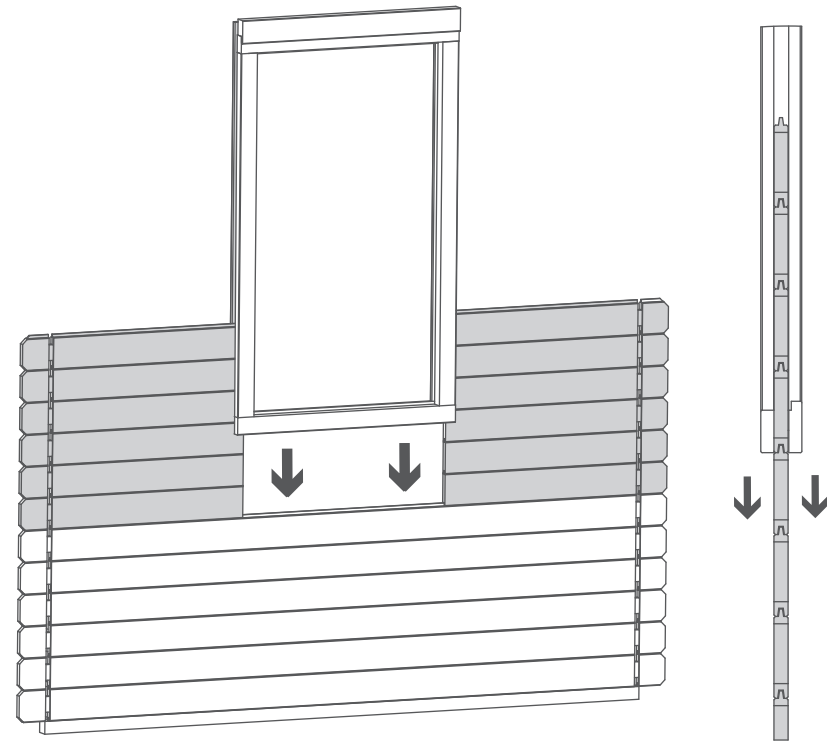

Step 15

Parts needed - No. 26 QTY 1

Make the log cabin level by adding another right hand board (**No. 26**) as shown in the diagram.

 Rubber Mallet may be required to fit parts.

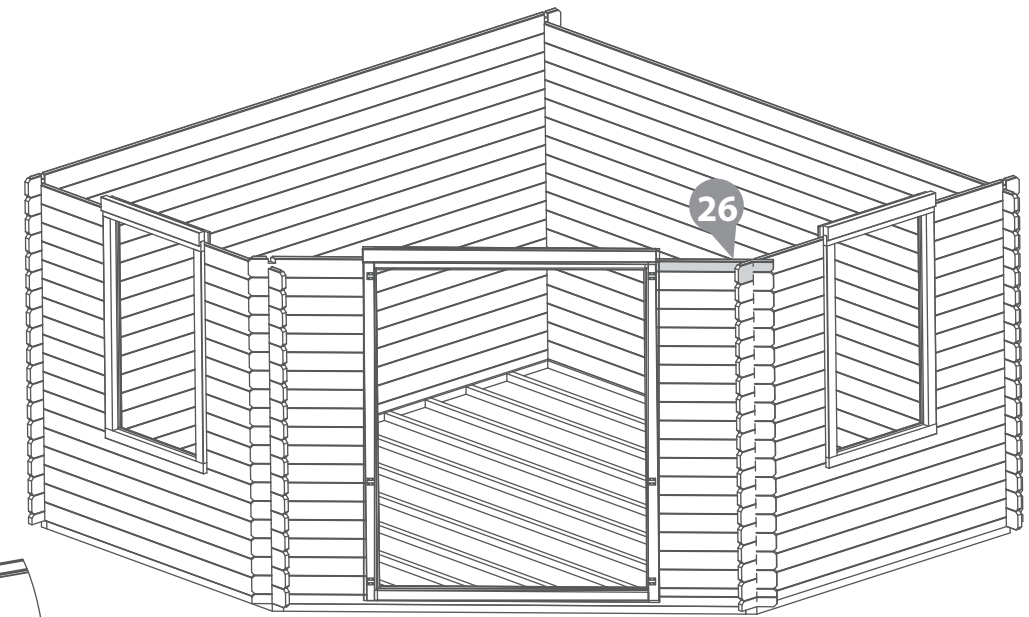
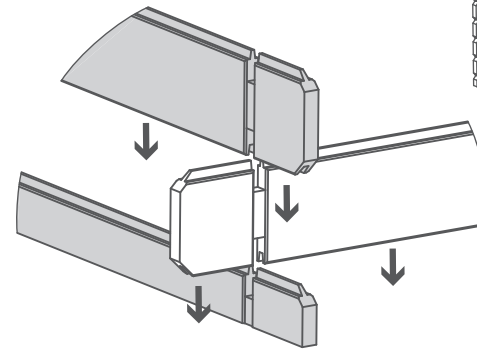

Step 14

**Parts needed - No. 23 QTY 12
No. 24 QTY 11
No. 29 QTY 12
No. 39 QTY 12**

Following the method as shown in the illustration, lay the next layer of boards (**No. 23, 24, 29 & 39**) onto the log cabin to bring the board level to the top of the window and door frames.

Please note when you get to the top of the boards the rear-right hand boards will be slightly lower.

****Ensure that the boards are level and flush with each other as you lay each one.**

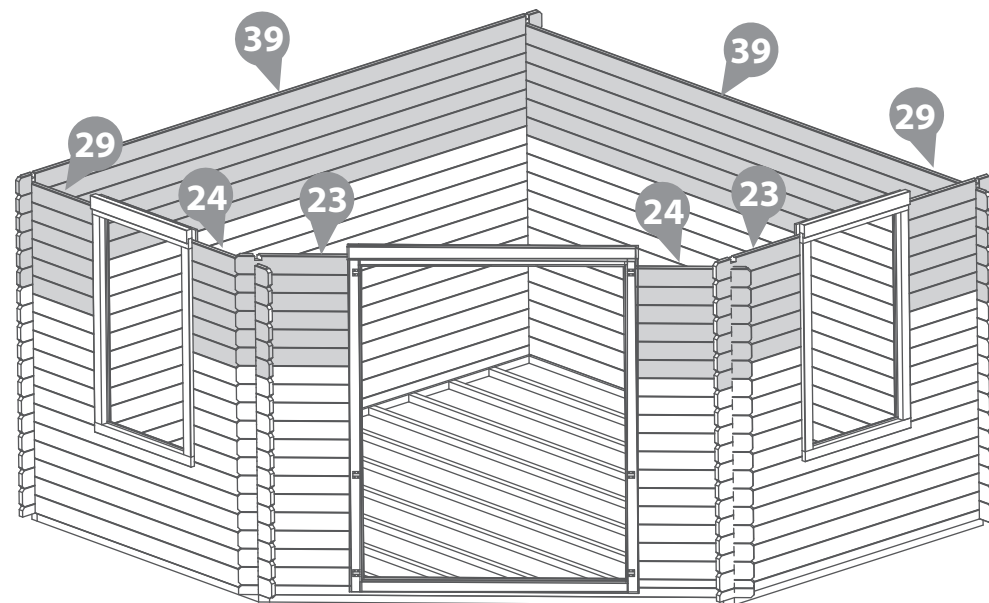

 Rubber Mallet may be required to fit parts.

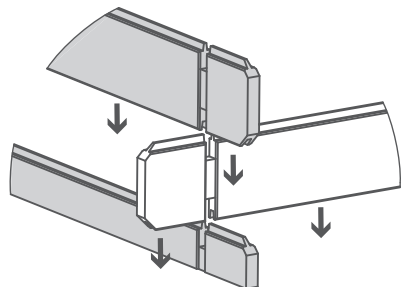

Step 16

**Parts needed - No. 28 QTY 1
No. 33 QTY 1
No. 35 QTY 1
No. 39 QTY 2**

Lay the next layer of boards (**No. 28, 33, 35 & 39**) onto the log cabin following the method as shown in the illustration, bringing the board level above the window and doors.

***Ensure that the boards are level and flush with each other as you lay each one.**

 Rubber Mallet may be required to fit parts.

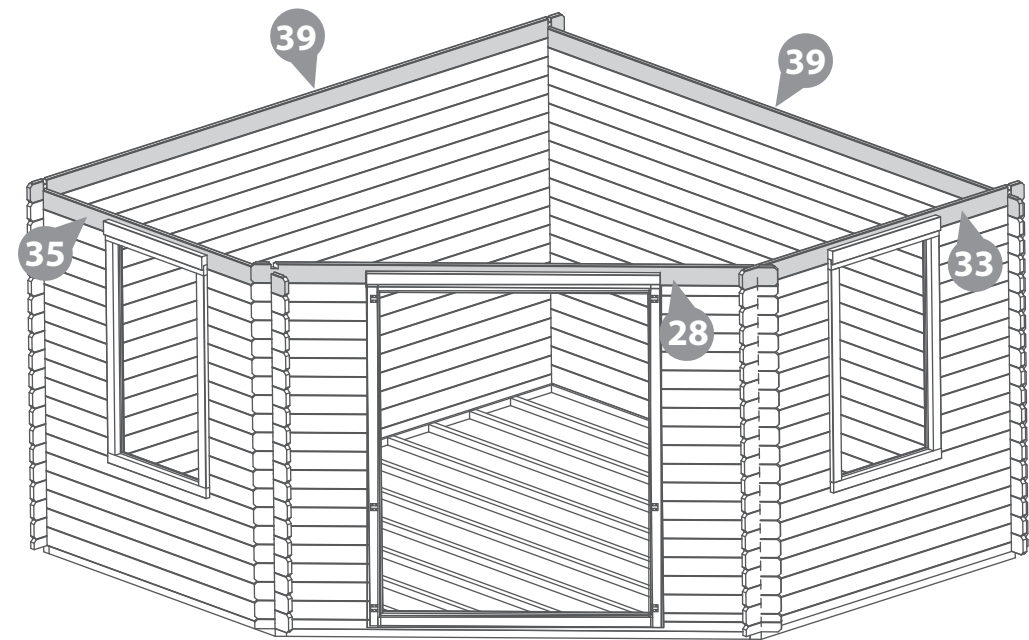
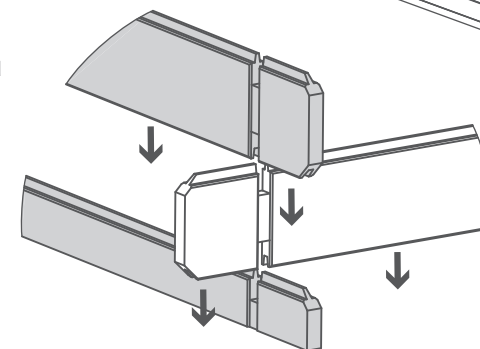

Step 17

Parts needed - No. 27 QTY 1
 No. 31 QTY 1
 No. 32 QTY 1
 No. 39 QTY 2

Lay the remaining boards (No. 27, 31, 32, 39) onto the log cabin following the method as shown in the illustration.

**Ensure that the boards are level and flush with each other as you lay each one.*

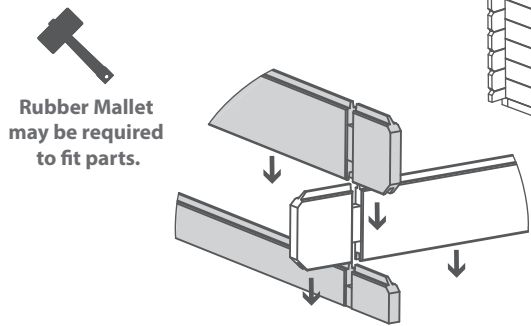
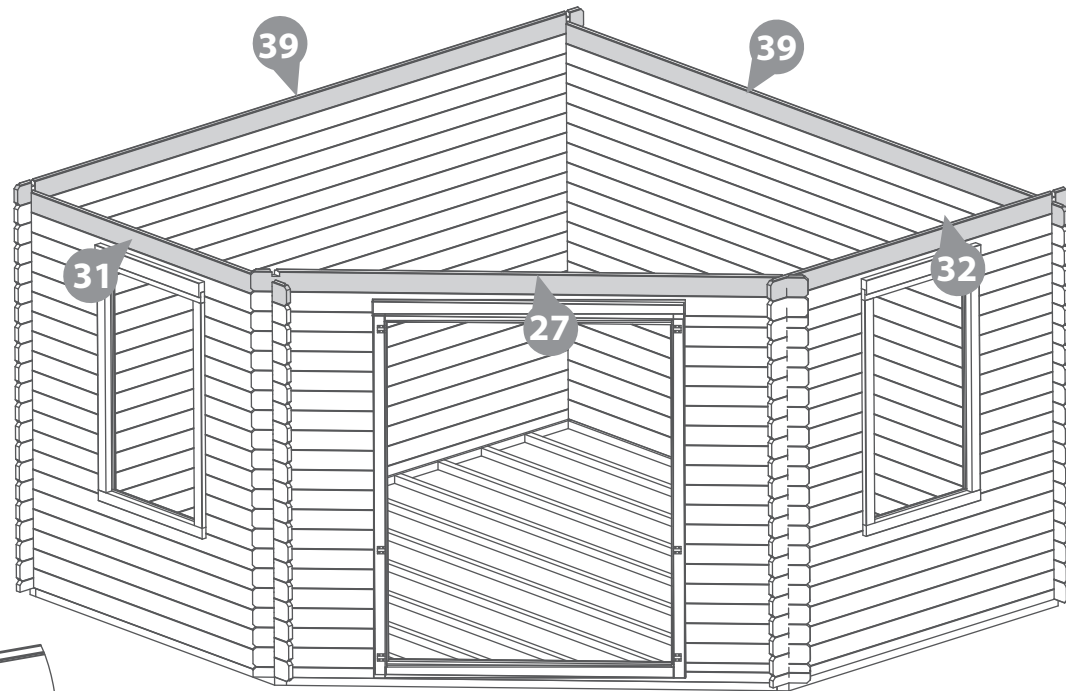

Step 18

Parts needed - No. 36 QTY 1
 No. 37 QTY 1

Lay the Finisher boards (No. 36 & 37) onto the front of the log cabin. Fix into position with 2x70mm screws per board by screwing through the notches.

**Ensure that the boards are level and flush with each other as you lay each one.*

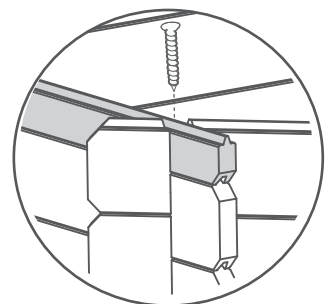
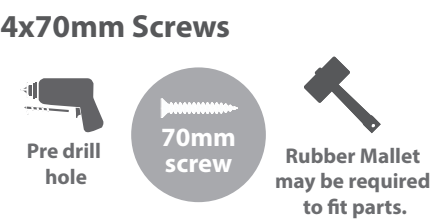
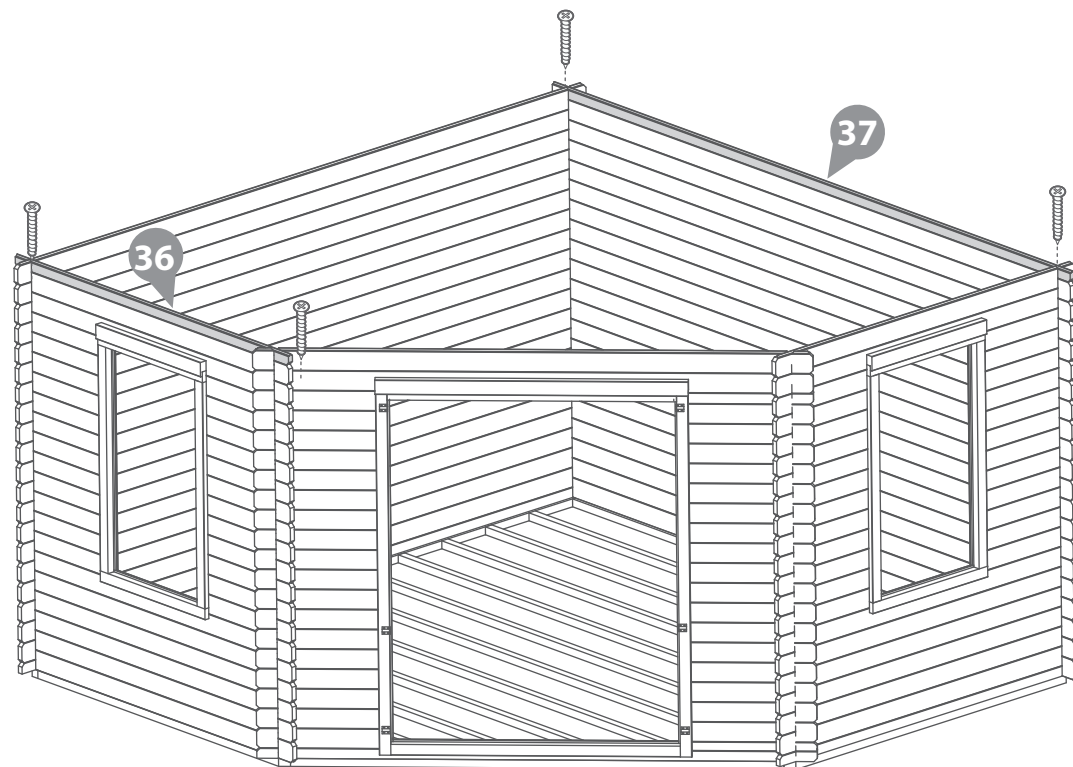

IMPORTANT: Pre-drill before fixing screws.

Step 19

Parts needed - No. 75 QTY 1

**** Please Note:**
 You can place your gable on either side of the log cabin, dependant on your needs. (See Contents page for reference)

Please ensure to construct your Roof by following either 'Roof Assembly 1' or 'Roof Assembly 2'; dependant on which side you placed the Gable.

Place the gable top (No. 75) onto the assembly. Fix into position by screwing through the notches as shown in the illustration.

**Ensure that the boards are level and Fush with each other as you lay each one.*

2x120mm Screws

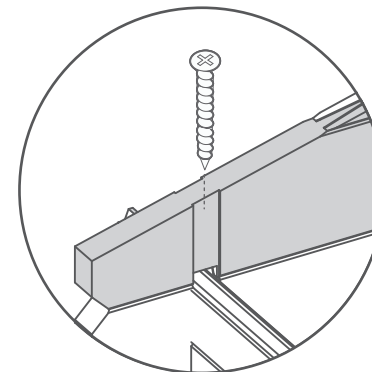
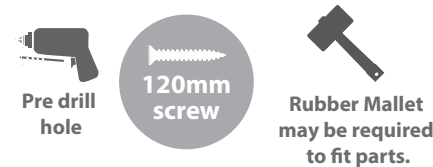

IMPORTANT: Pre-drill before fixing screws.

Roof Assembly 1

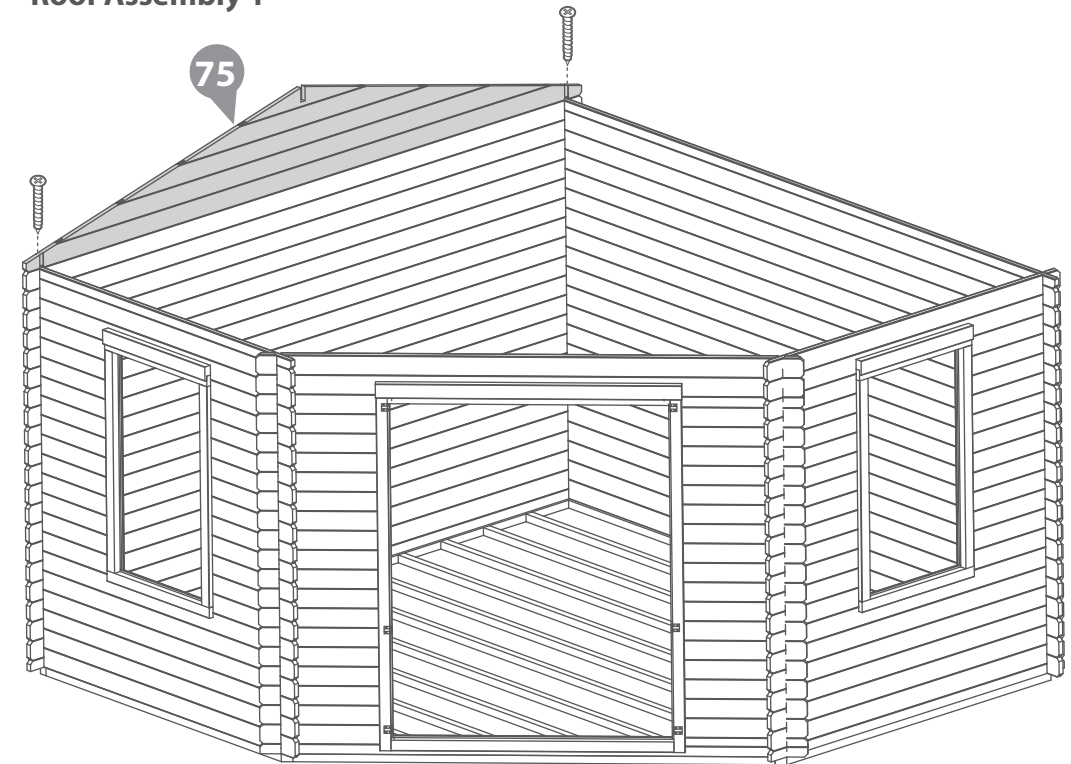

Roof Assembly 2

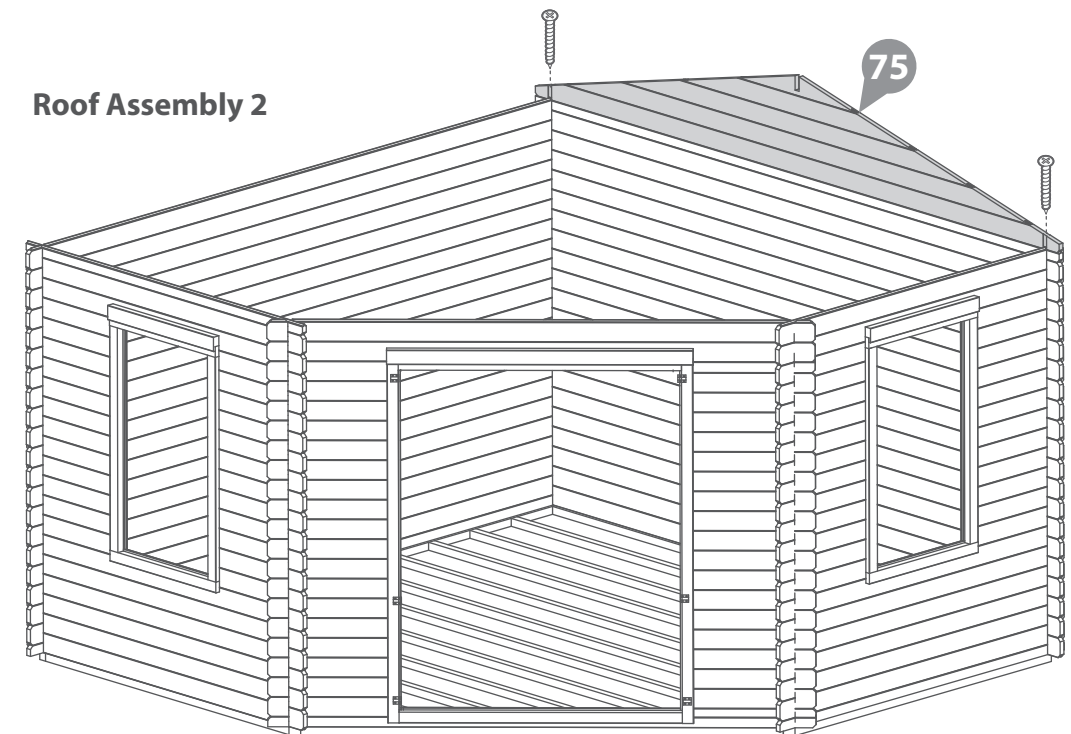

Step 20
Parts needed - No. 52 QTY 1

Align the Roof Purlin (No. 52) into the cut out slot on the gable, ensuring the purlin interlocks the boards.

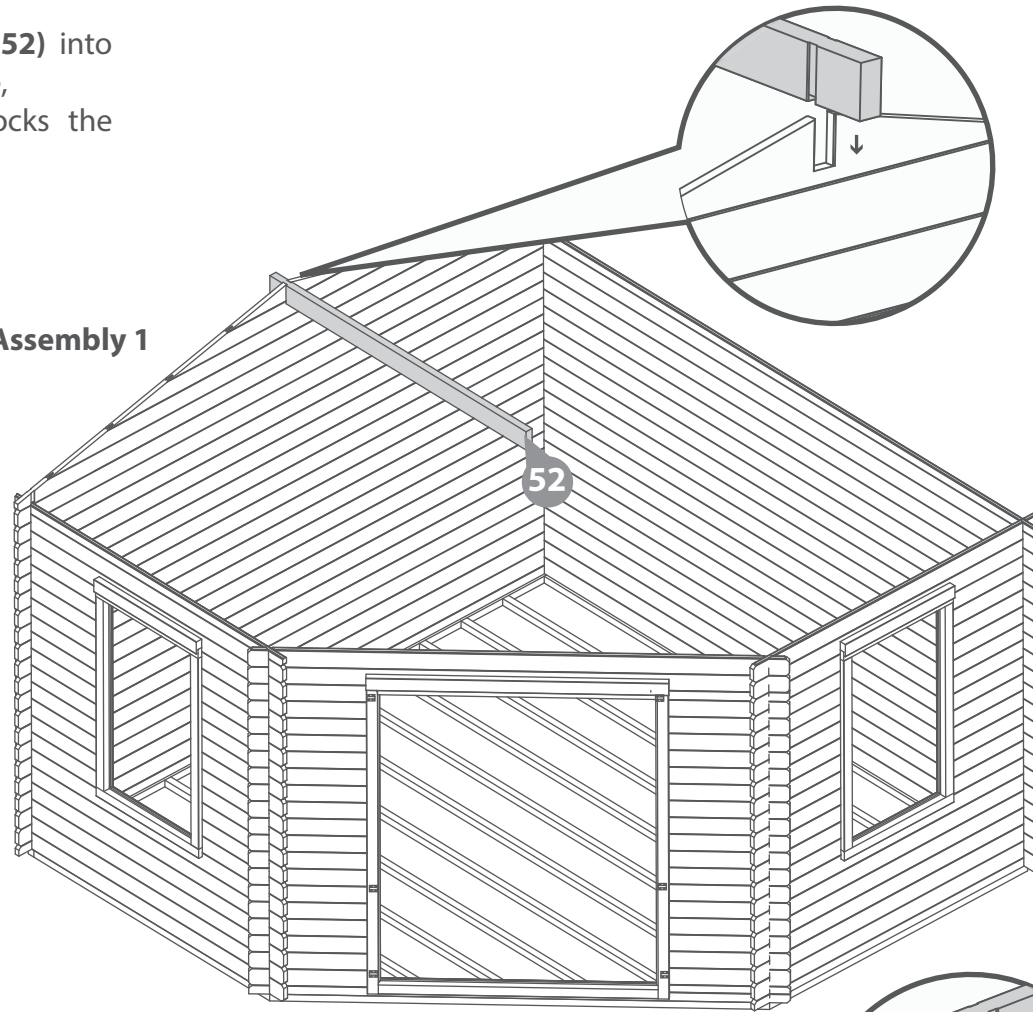

Rubber Mallet
may be required
to fit parts.

Roof Assembly 1

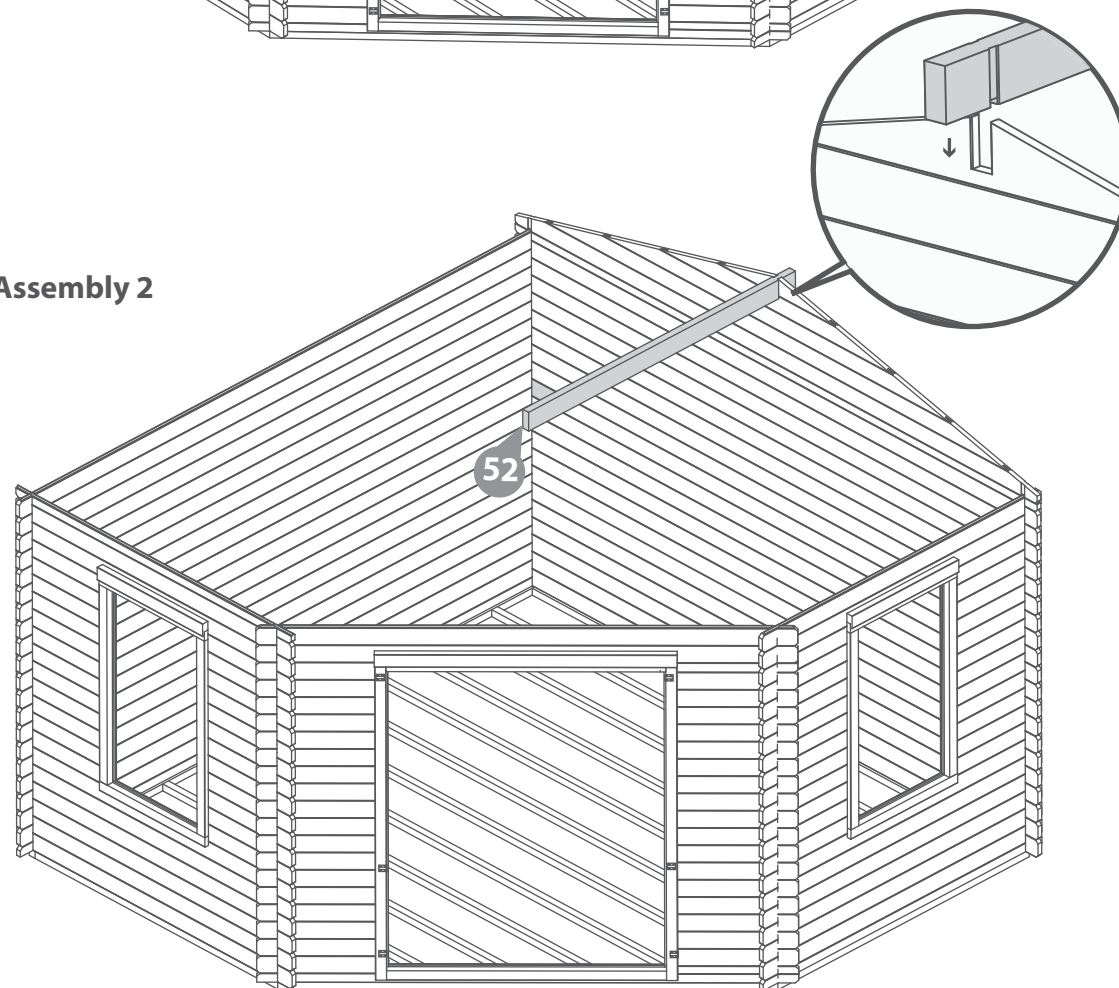

IMPORTANT: Pre-drill before fixing screws.

Roof Assembly 2



Step 21
Parts needed - No. 45 QTY 1
No. 47 QTY 1
No. 48 QTY 1

Roof Assembly 1:

Place The Central Roof Truss 'Roof Truss D' (No.48) flush to the end of the Roof Purlin (No.52).

Place Roof Truss C (No.47) and 'Roof Truss A' (No. 45) on to either side of the Roof Purlin (No.52) ensuring they sit flush to the end, creating a 'T' shape as shown in the illustration.

Fix in place by screwing into the purlin at an angle as shown in the illustration using 1x90mm screws per Truss.

3x90mm Screws

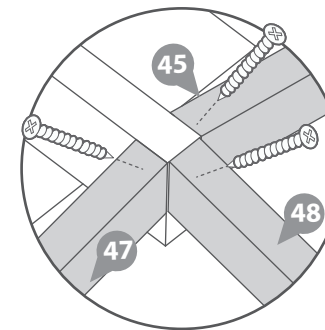

Roof Assembly 2:

Place The Central Roof Truss 'Roof Truss C' (No.47) flush to the end of the Roof Purlin (No.52).

Place Roof Truss D (No.48) and 'Roof Truss A' (No. 45) on to either side of the Roof Purlin (No.52) ensuring they sit flush to the end, creating a 'T' shape as shown in the illustration.

Fix in place by screwing into the purlin at an angle as shown in the illustration using 1x90mm screws per Truss.

3x90mm Screws

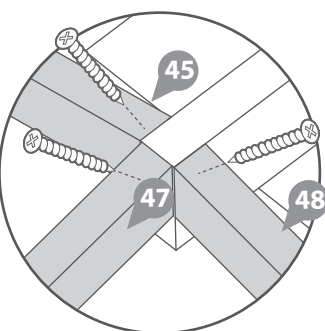
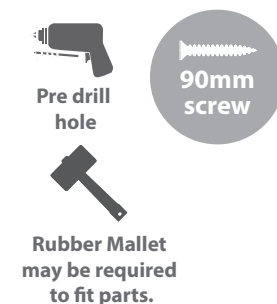

IMPORTANT: Pre-drill before fixing screws.

Roof Assembly 1

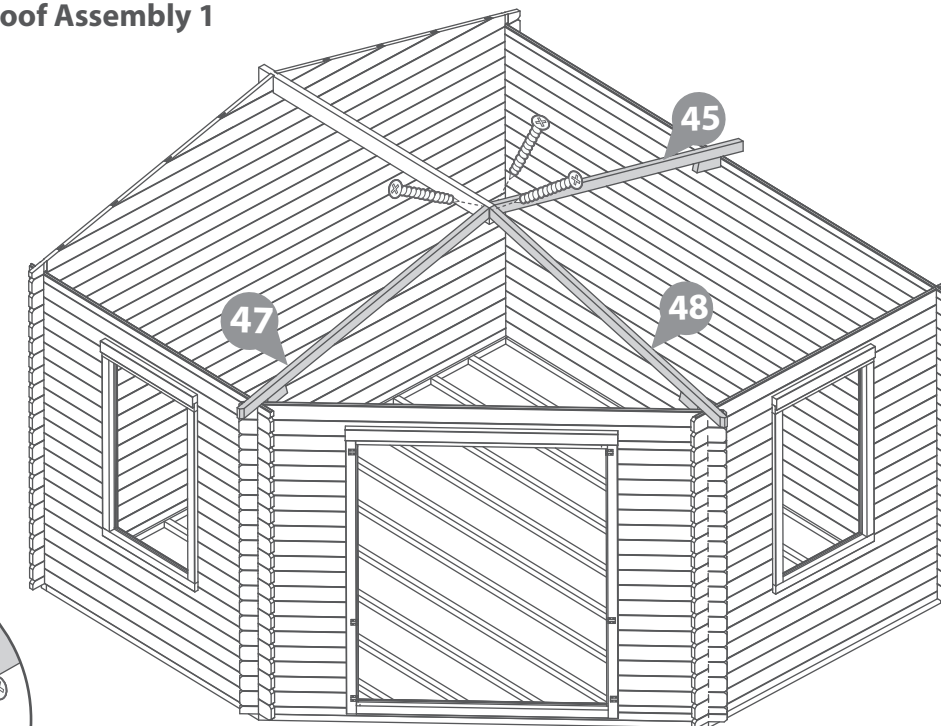

Roof Assembly 2

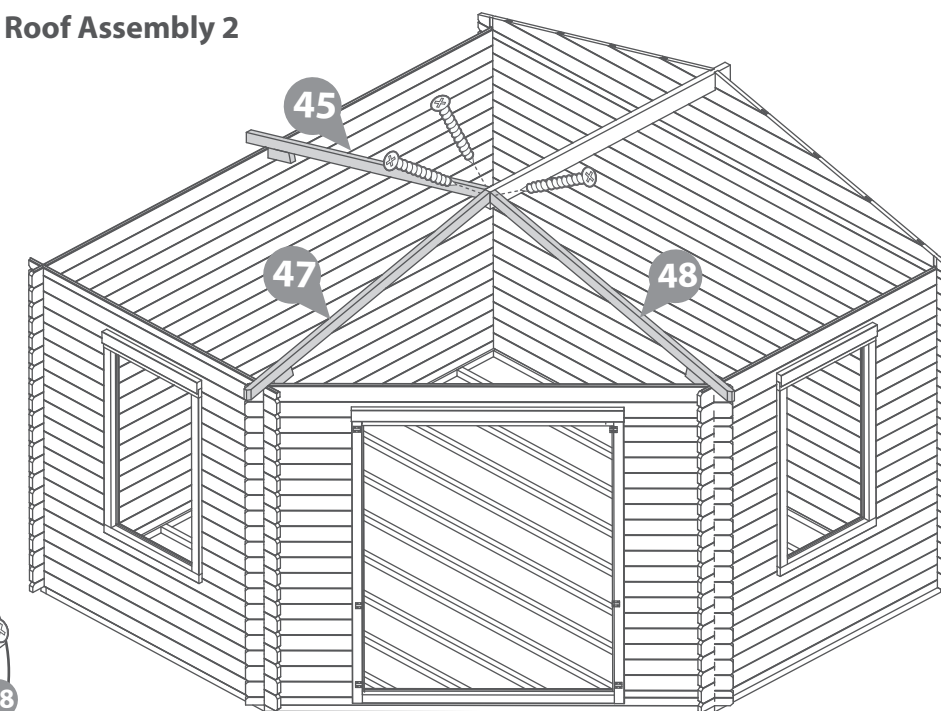

Step 22

**Parts needed - No. 46 QTY 1
No. 49 QTY 1**

Locate 'Roof Truss B' (No. 46) between 'Roof Truss A' (No.45) and the central roof truss, ensuring the faces are flush.

Locate 'Roof Truss E' (No. 49) between 'Roof Truss C' (No.47) and 'Roof Truss D' (No.48) ensuring the faces are flush.

Fix in place by screwing into the purlin at an angle as shown in the illustration using 1x90mm screw per truss.

2x90mm Screws



IMPORTANT: Pre-drill before fixing screws.

Roof Assembly 1

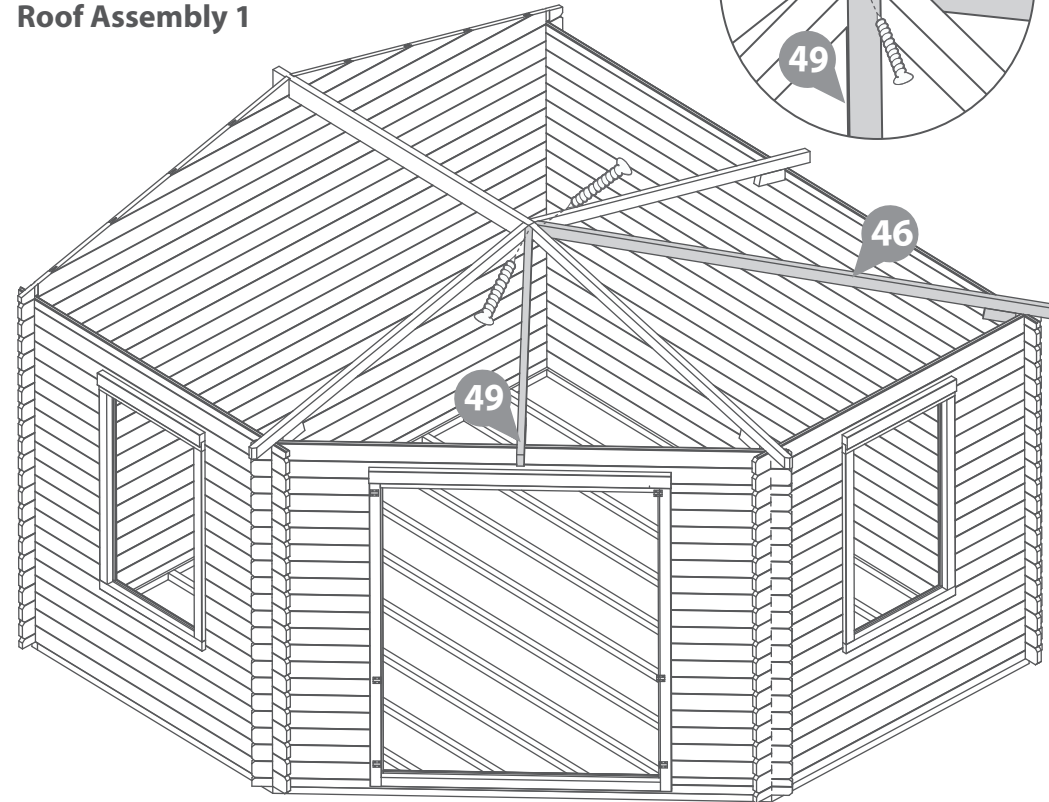

Roof Assembly 2

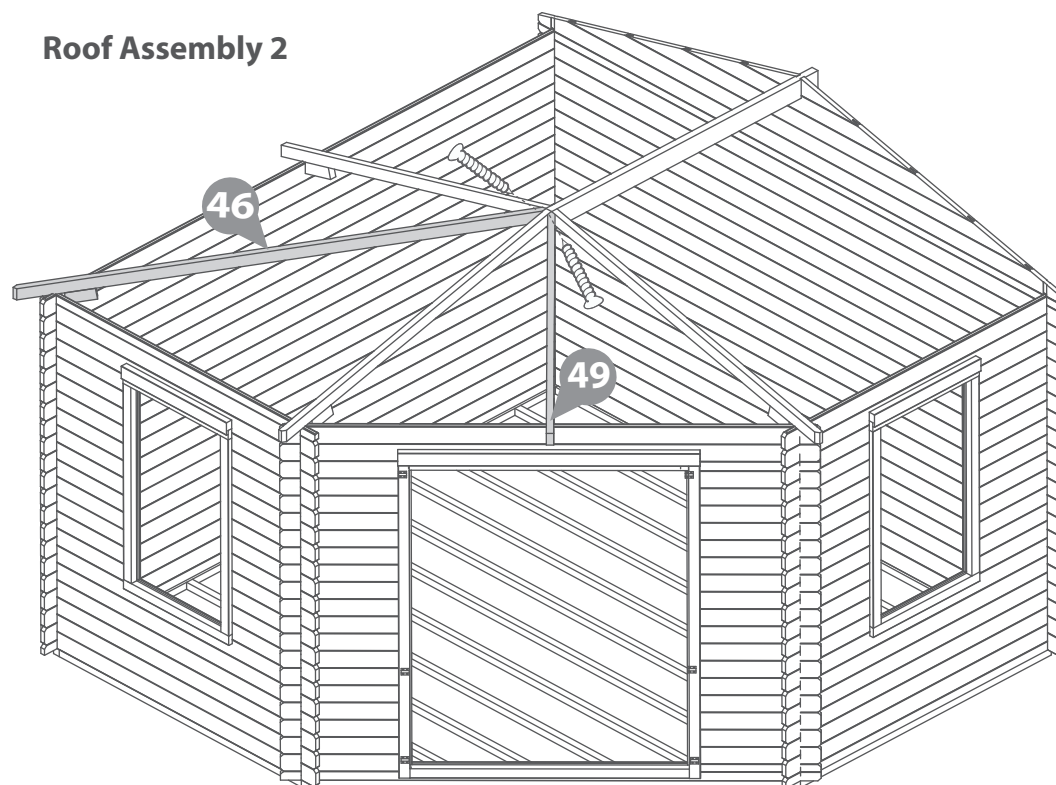

Step 23

Parts needed - No. 45 QTY 2

Place 2x 'Roof Truss A' (No. 45) flush to the inside of the Gable (No. 75), ensuring the faces sit flat on the Purlin as shown in the illustration.

Fix in place by screwing into the purlin at an angle as shown in the illustration using 1x90mm screws per Roof Truss.

2x90mm Screws

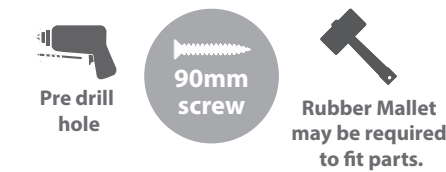

IMPORTANT: Pre-drill before fixing screws.

Roof Assembly 1

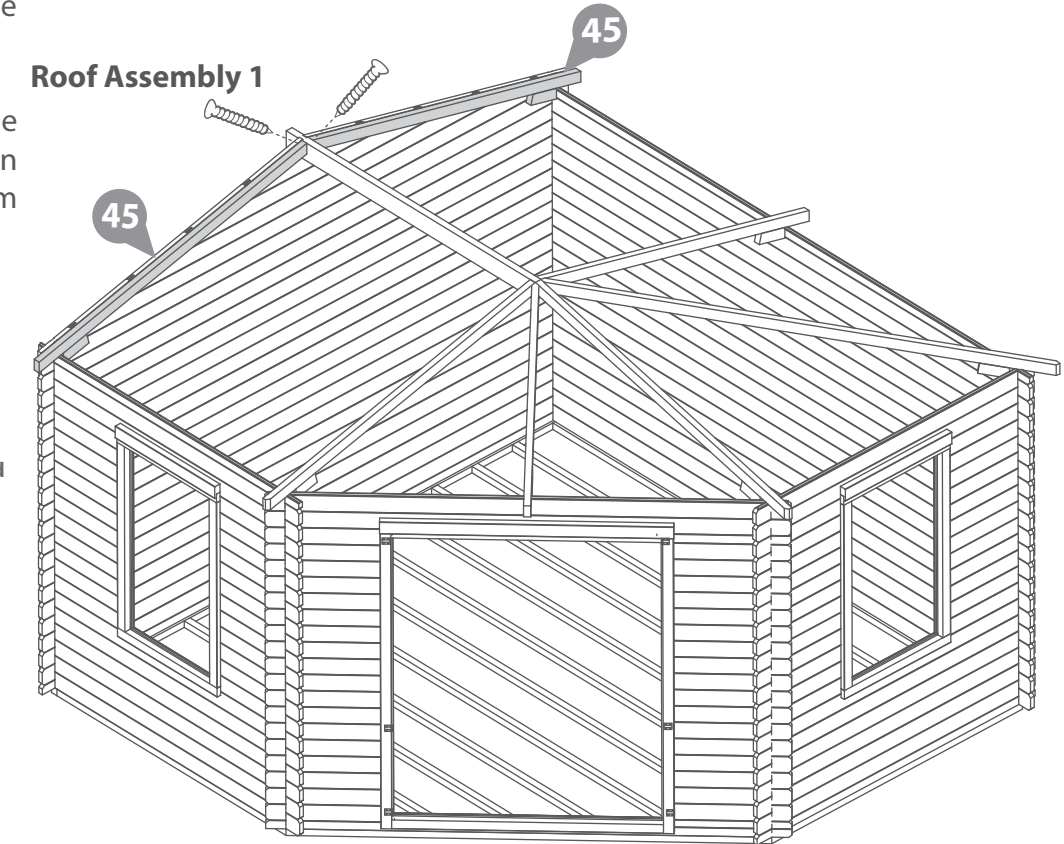

Roof Assembly 2

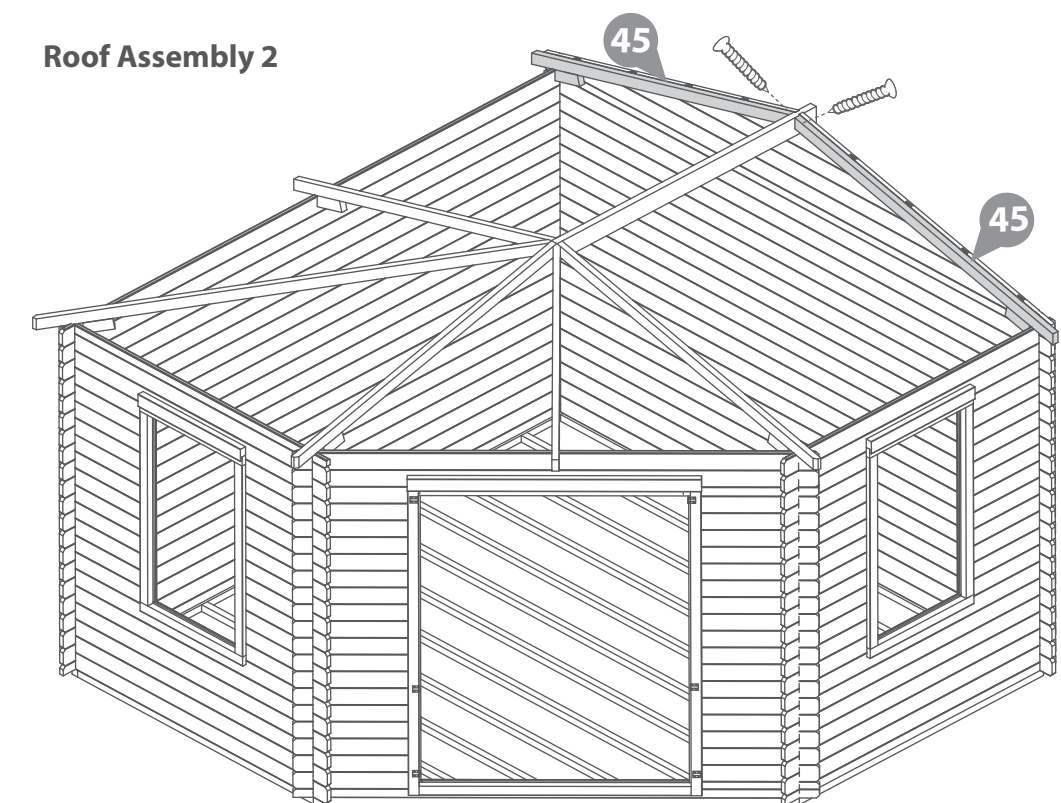

Step 24
Parts needed - No. 50 QTY 1
No. 51 QTY 1

Secure the shortest Roof Truss' (No. 50 & 51) to 'Roof Truss B' (No. 46) as shown in the illustration using 2x70mm screws per truss.

**Ensure the angled side of the short truss is flush with the side of the long truss. Then make sure the block under the short truss is flush against the wall of the building.*

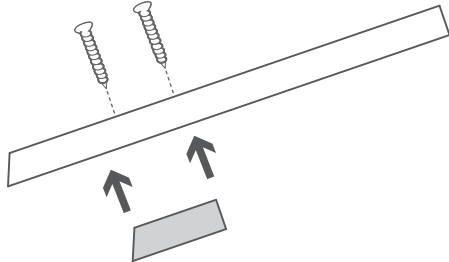
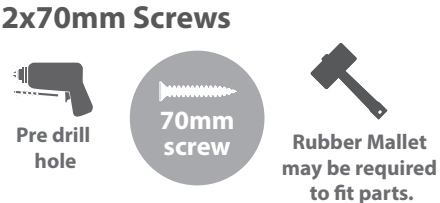

Please note: You can adjust the blocks attached to the roof truss' if necessary.

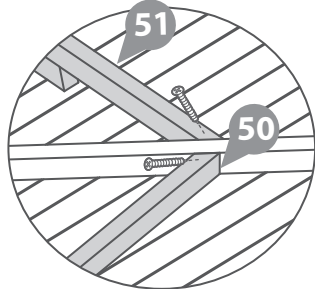

IMPORTANT: Pre-drill before fixing screws.

Roof Assembly 1

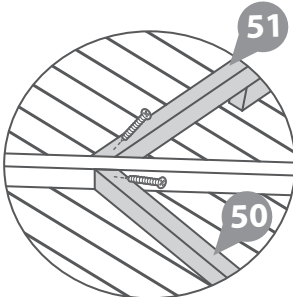
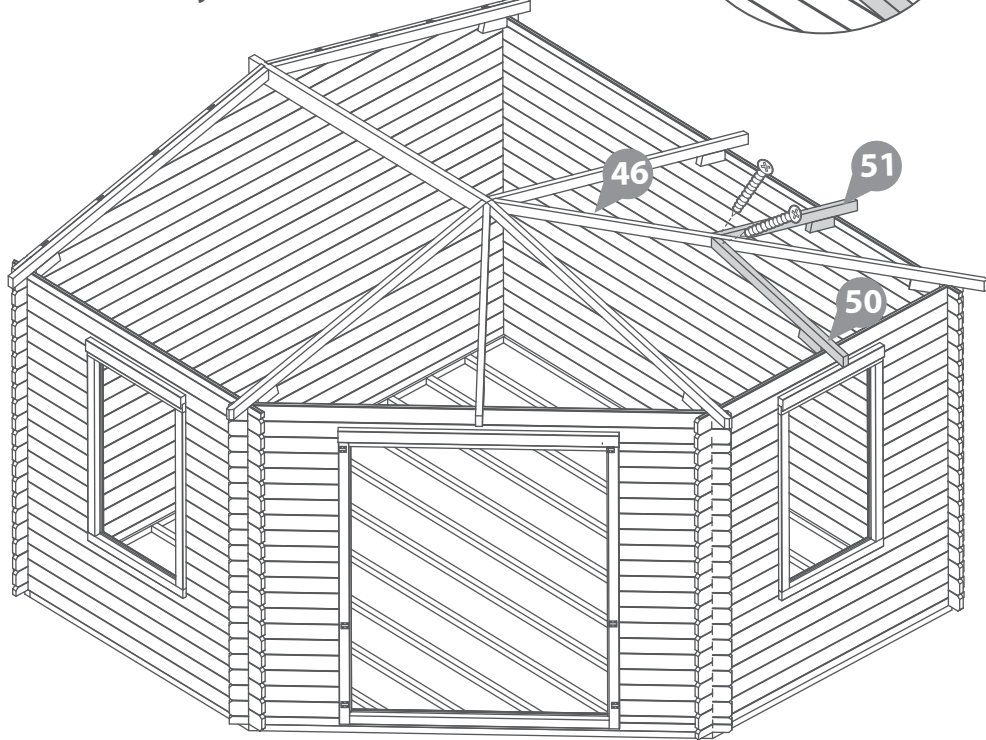

Roof Assembly 2

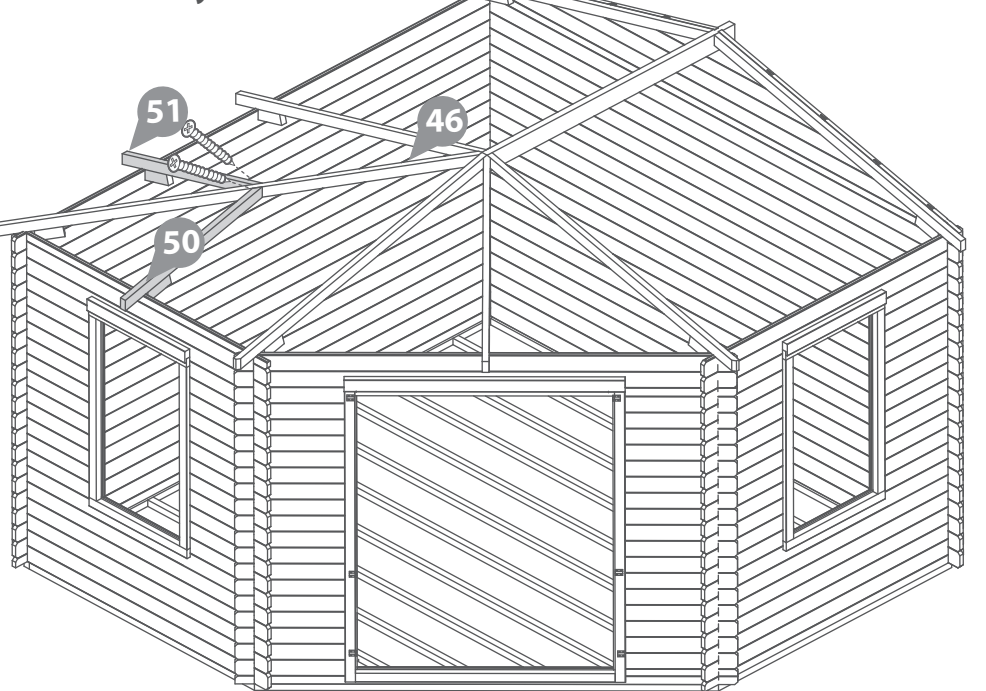

Step 25
Parts needed - No. 40 QTY 6
No. 41 QTY 1
No. 42 QTY 1
No. 43 QTY 1
No. 44 QTY 1

Place the finisher boards (No. 40, 41, 42, 43 & 44) around the log cabin, locating each block flush to the truss'.

Ensure there is at least a 42mm gap between parts No. 40 & 40 on both sides of the log cabin.

Some adjustment may be required to ensure the roof structure rests correctly.

Secure each board by screwing into the Roof Truss, using 2x70mm screws per board, ensuring to stagger the screws to avoid colliding.

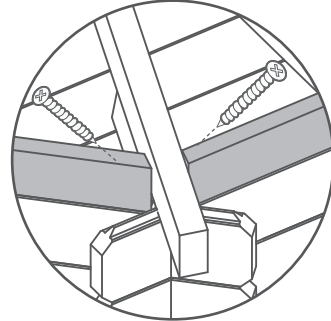
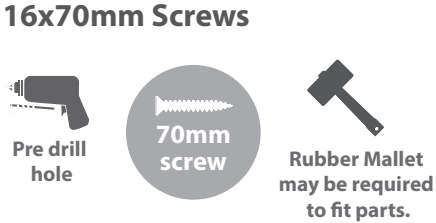

IMPORTANT: Pre-drill before fixing screws.

Roof Assembly 1

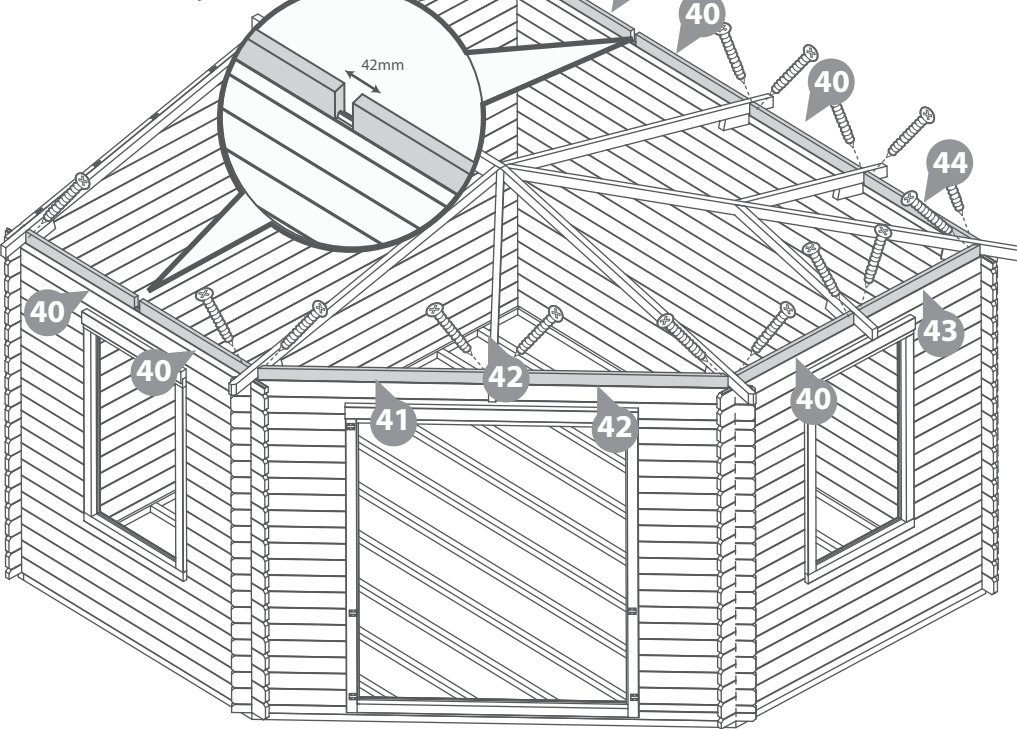

Roof Assembly 2

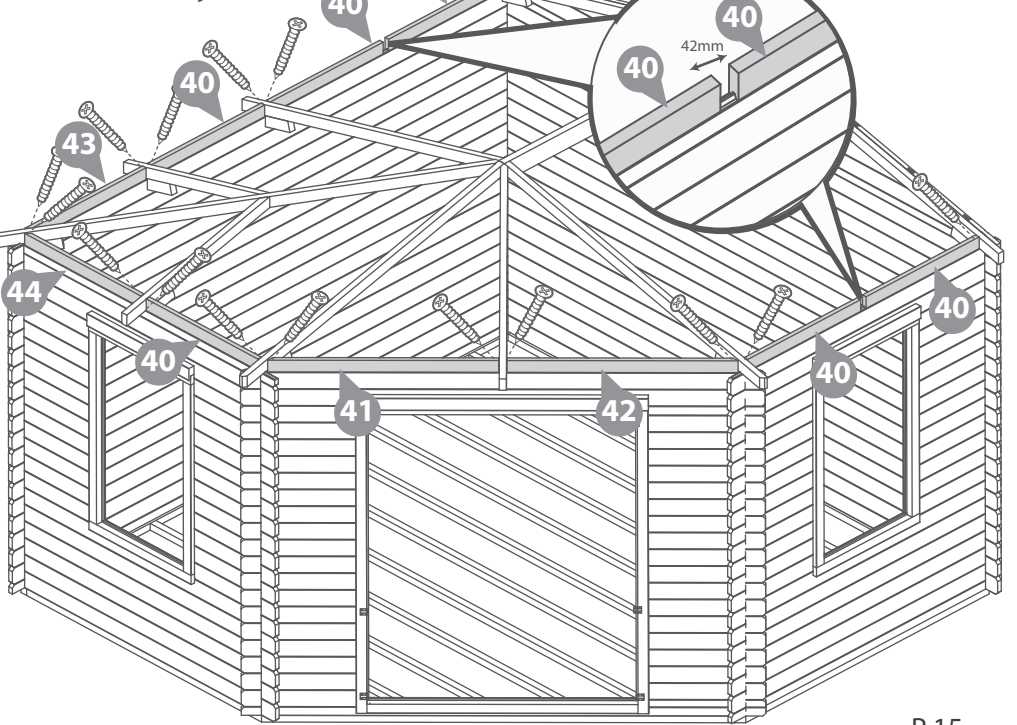

Step 26

Parts needed - No. 45 QTY 2

Locate the last two 'Roof Truss A' (**No. 45**) into the 42mm gaps between the finisher boards **No.40 & 40** and on both sides of the log cabin, as shown in the illustration.

Some adjustment may be required to ensure the roof structure rests correctly.

Fix in place by screwing into the purlin at an angle as shown in the illustration using 1x90mm screws per Roof Truss.

Secure the boards (**No.40**) in place by screwing through the purlin using 1x70mm screw per board, ensuring to stagger the screws to avoid colliding.

4x70mm Screws
2x90mm Screws



Rubber Mallet may be required to fit parts.

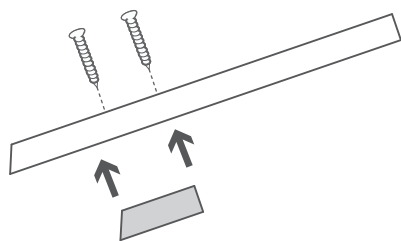
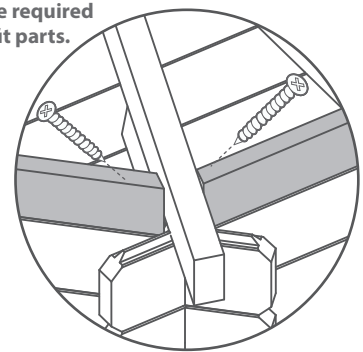

Please note: You can adjust the blocks attached to the roof truss' if necessary.

IMPORTANT: Pre-drill before fixing screws.

Roof Assembly 1

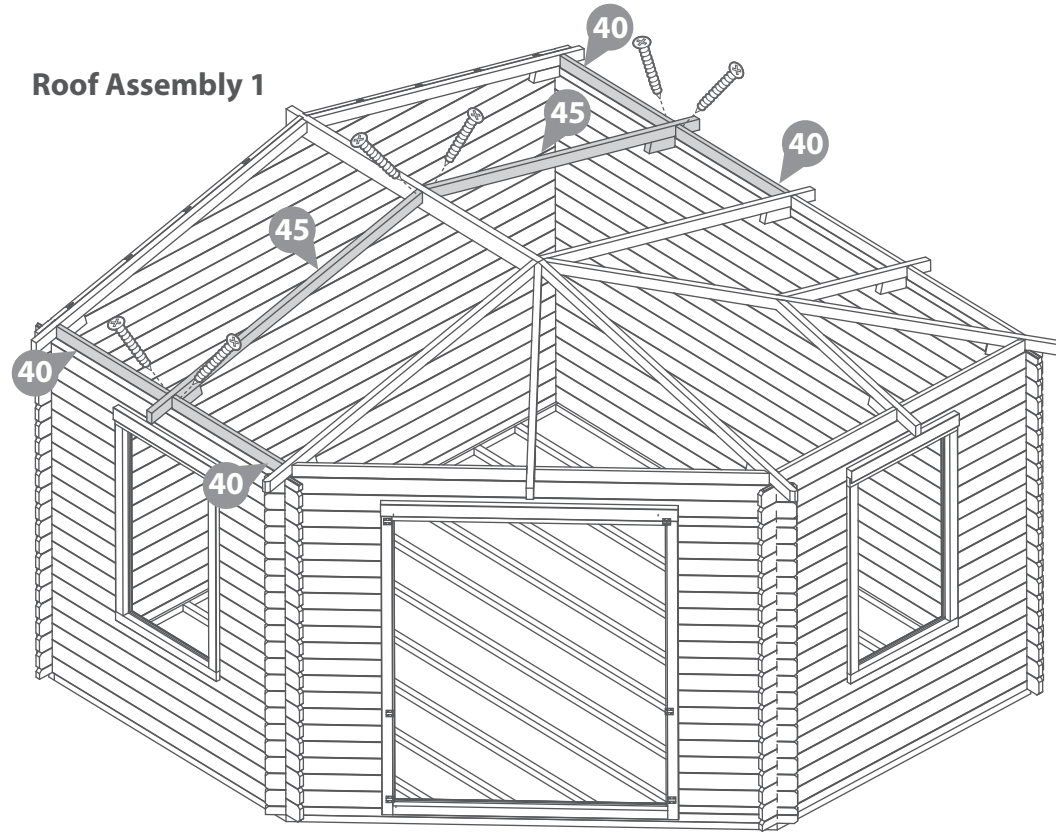

Roof Assembly 2

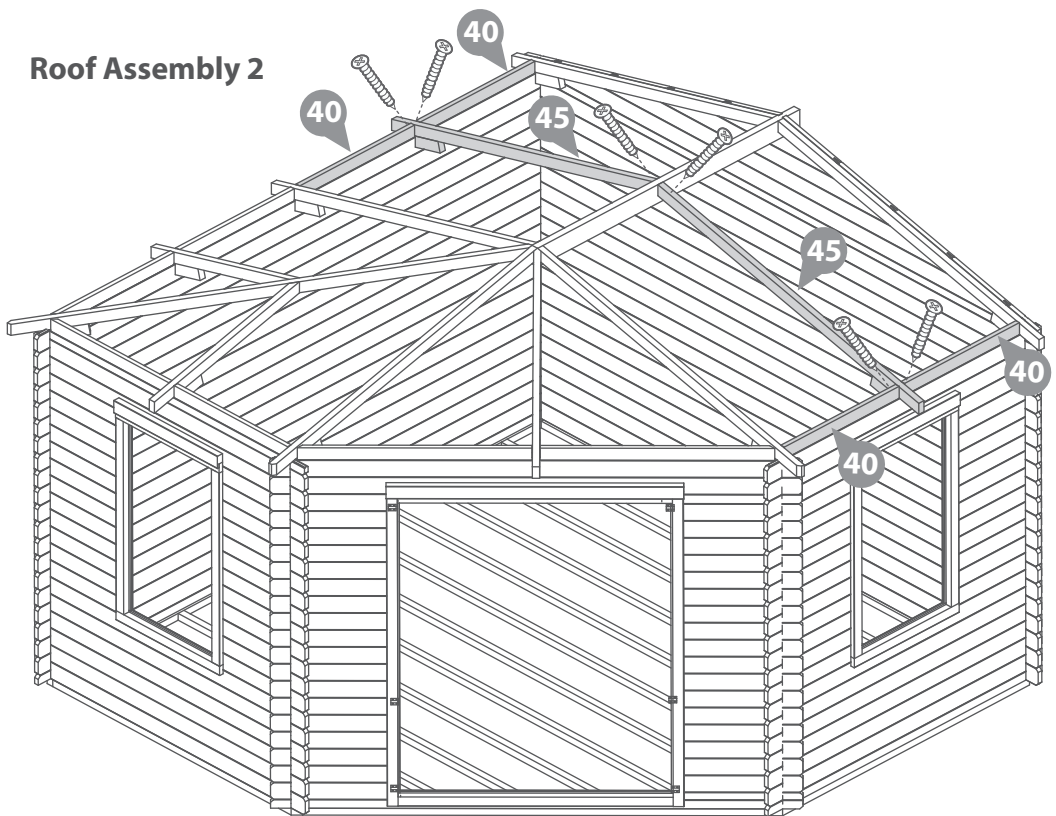

Step 27

You can now fix the assembled roof truss's and roof purlin to the log cabin, making sure the attached blocks sit inside the assembly.

Some adjustment may be required to ensure the roof structure rests correctly.

***Before fixing the roof trusses in place, ensure the small blocks attached to each truss sit up to the log cabin walls, without pushing the walls outwards. Adjust the roof blocks if necessary.**

Once in position fix to the log cabin using 1x120mm screw per truss as shown in the diagram. Ensure to stagger screws to avoid colliding.

Secure the Roof Purlin to the log cabin by screwing through the purlin into the gable using 2x70mm screws

11x120mm Screws
2x70mm Screws

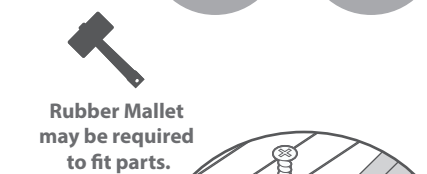
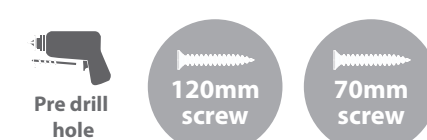

Rubber Mallet may be required to fit parts.

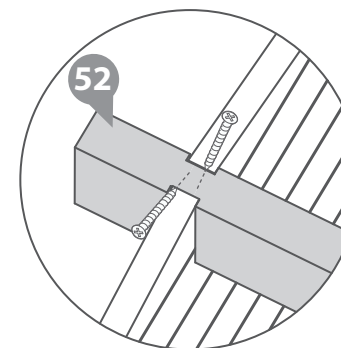
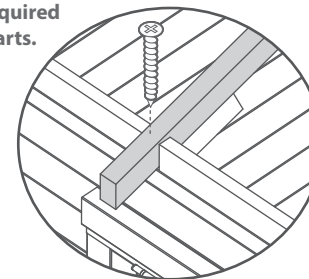

IMPORTANT: Pre-drill before fixing screws.

Roof Assembly 1

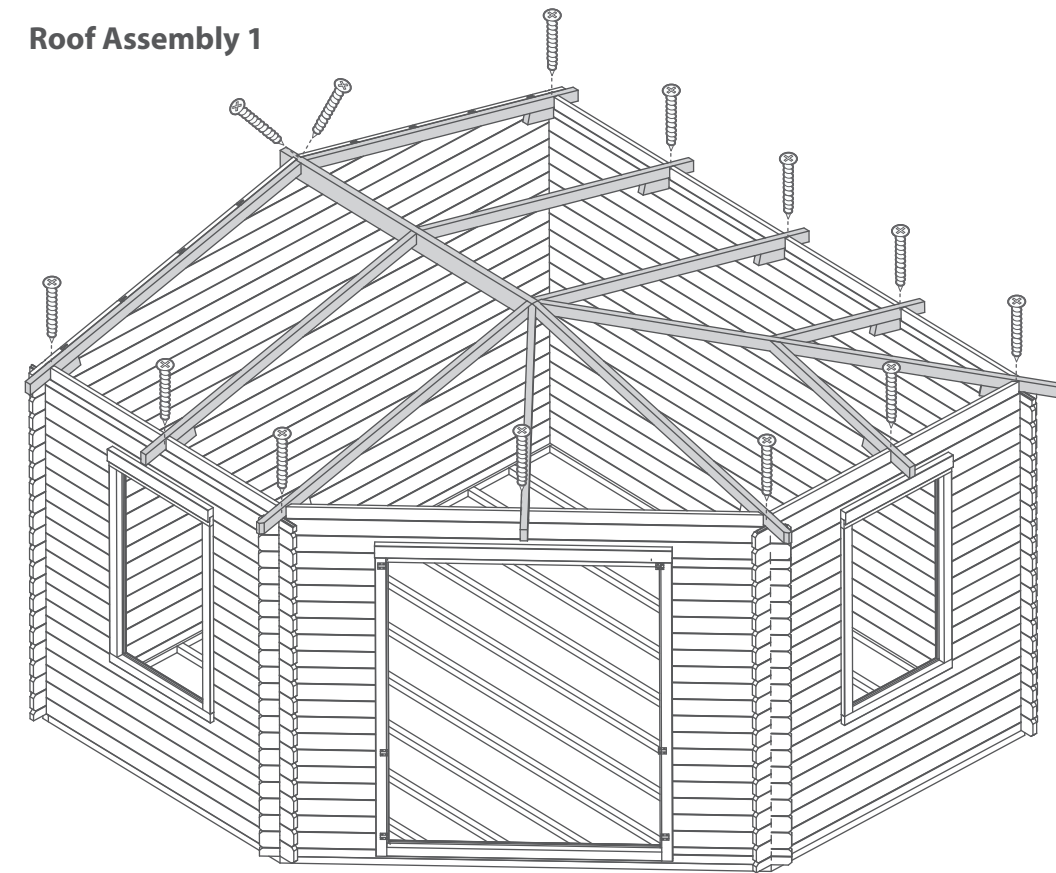

Roof Assembly 2

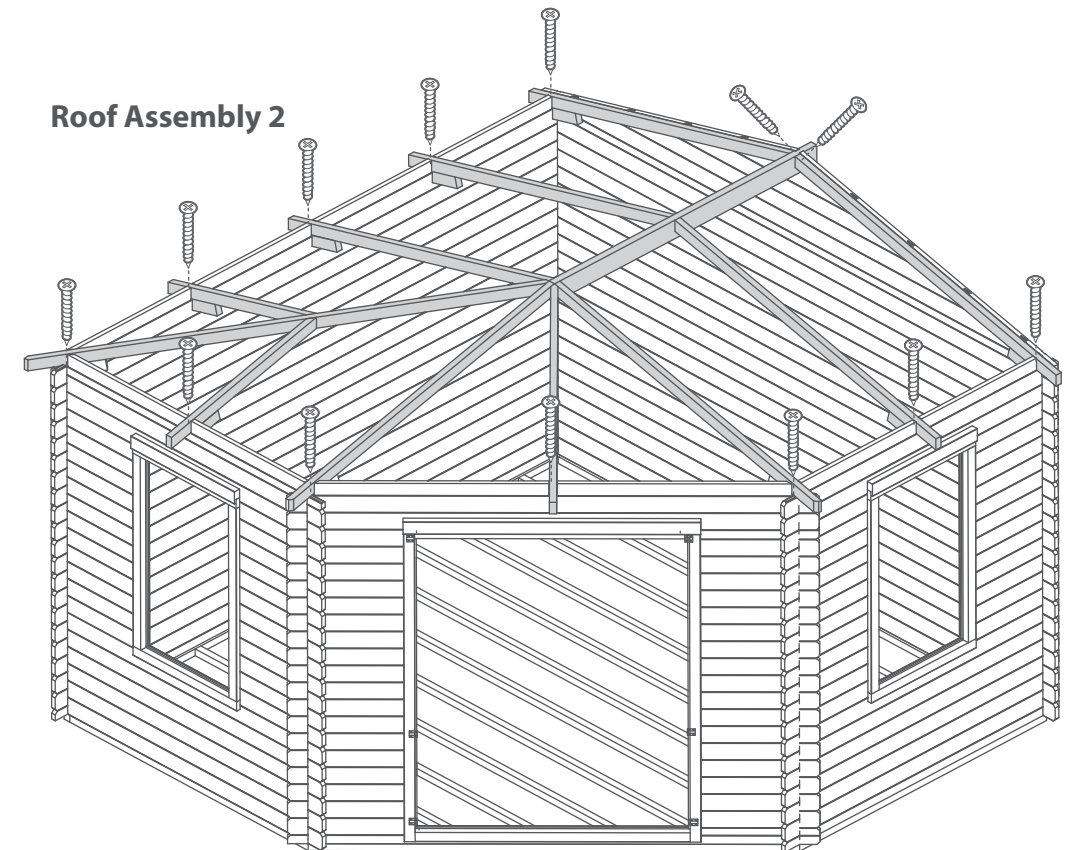

Step 28

Parts needed - No. 72 QTY 2 Pack A
 No. 73 QTY 2 Pack B
 No. 74 QTY 1 Pack C

***HINT: keep the roof board packs separate to prevent mixing them up.**

Place the first board from each 'Roof Board Pack' (A, B, & C) onto the roof assembly, working around the structure, building each layer of roof boards one by one.

Once you are happy with the fit of the roof boards, fix the boards into place using 40mm screws, ensuring to fix through the roof board into the truss below.

30x40mm screws

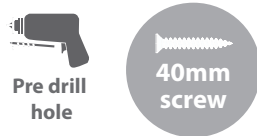

Roof Assembly 1

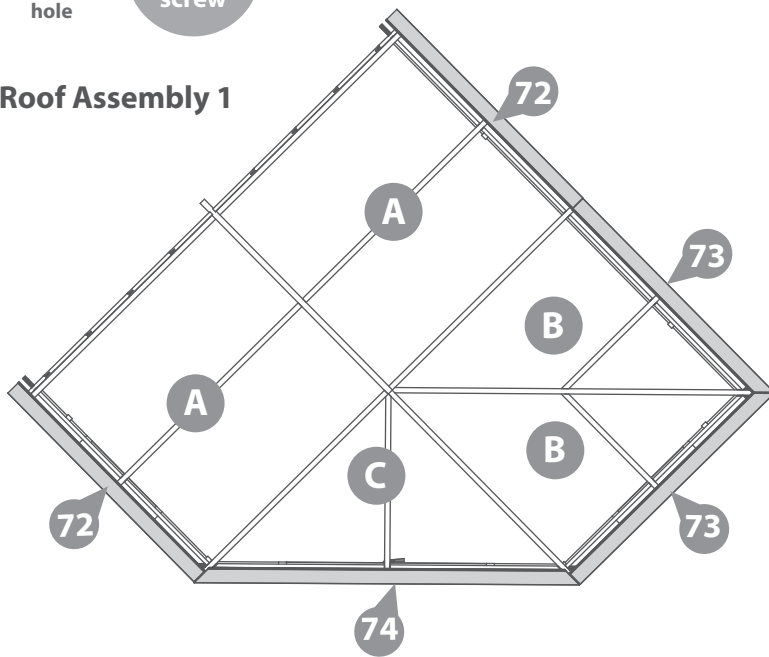

Roof Assembly 2

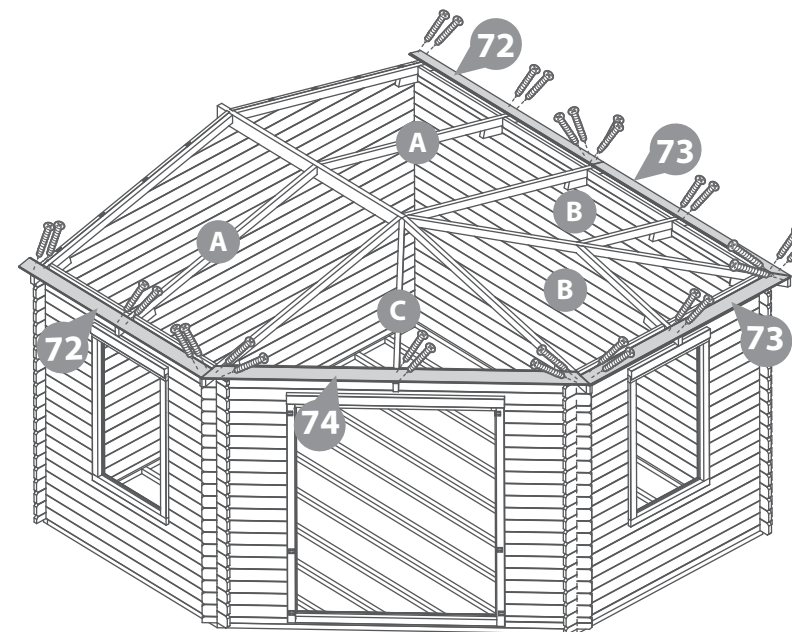
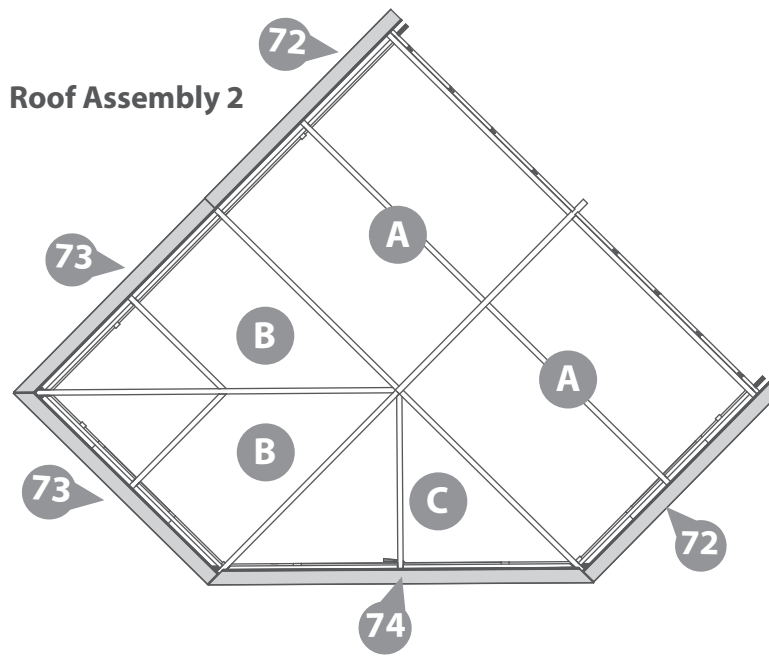

Roof Assembly 1

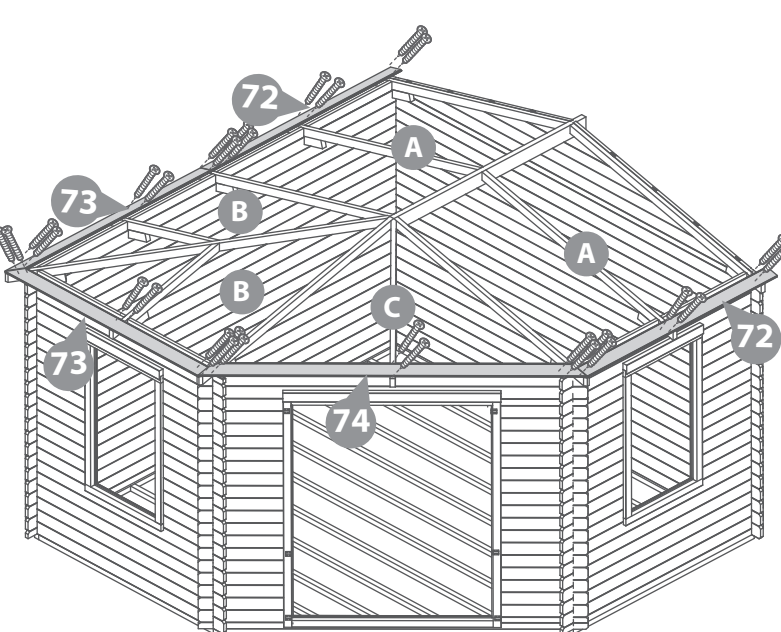

Roof Assembly 2

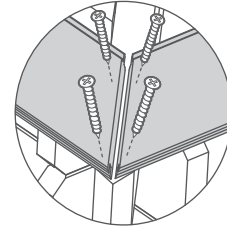

IMPORTANT: Pre-drill before fixing screws.

Step 29

Parts needed - No. 72
 No. 73
 No. 74

***HINT: keep the roof board packs separate so they do not get mixed up.**

Start arranging the roof board packs (A, B, & C) onto the roof assembly, working around the structure, building each layer of roof boards one by one.

Use the spacer (No.70) to create an expansion gap between each roof board if installing during low levels of moisture (summer). This creates an expansion gap for the boards to move into during high levels of moisture (winter).

Once you are happy with the fit of the roof boards, fix the 2nd, 3rd and 4th boards into place as shown in the diagram, using 40mm screws, ensuring to fix through the roof board into the truss below.

90x40mm Screws

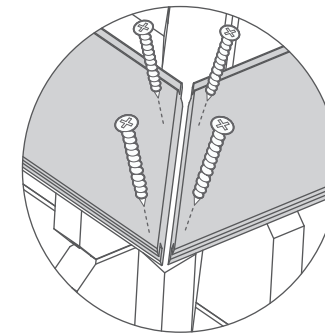

IMPORTANT: Pre-drill before fixing screws.

Roof Assembly 1

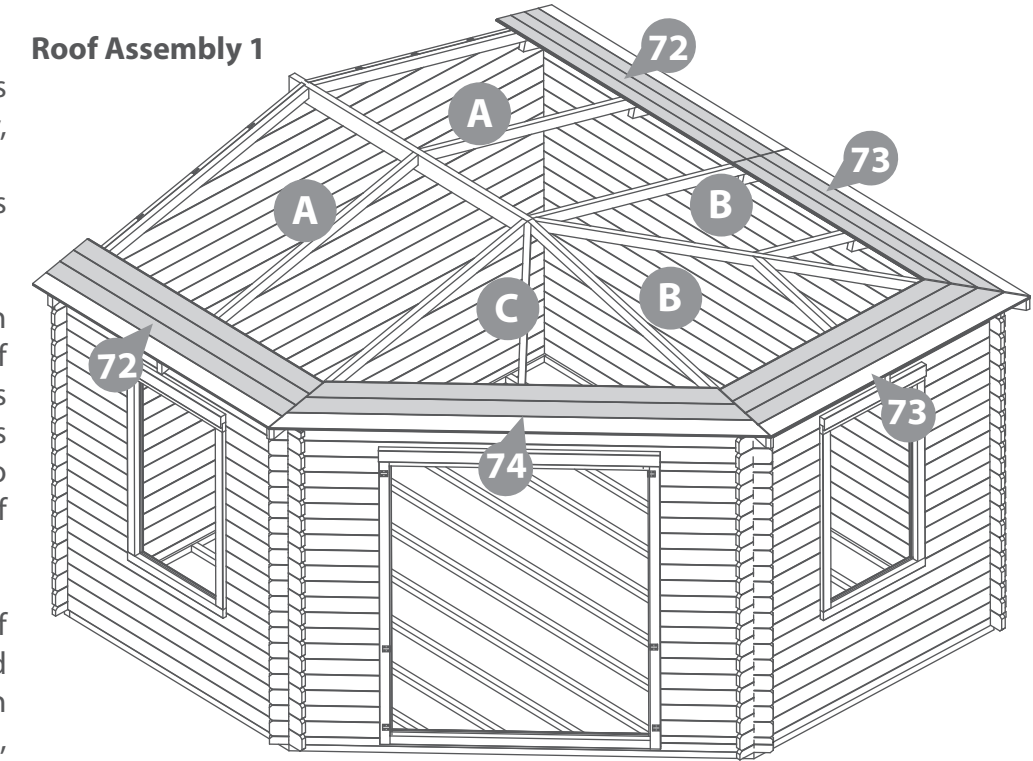

Roof Assembly 2

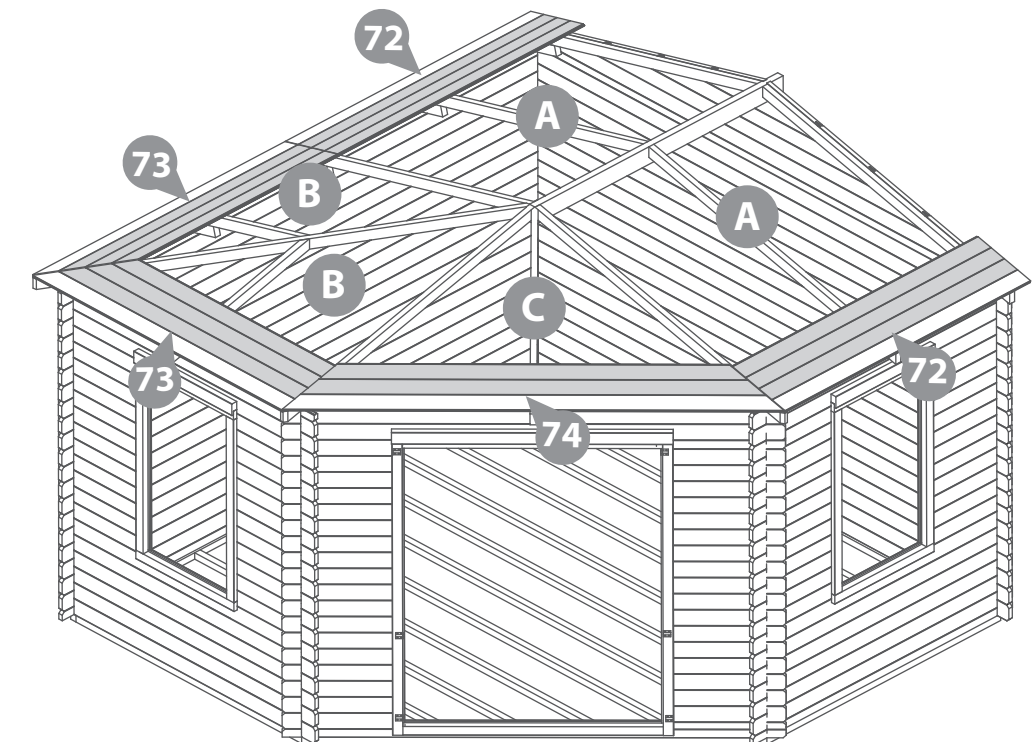

Step 30
Parts needed - No. 72
No. 73
No. 74

***HINT: keep the roof board packs separate so they do not get mixed up.**

Continue arranging the roof board packs (A, B, & C) onto the roof assembly, working around the structure, building each layer of roof boards one by one.

Use the spacer (No.70) to create an expansion gap between each roof board if installing during low levels of moisture (summer). This creates an expansion gap for the boards to move into during high levels of moisture (winter).

Once you are happy with the fit of the roof boards, fix the 5th, 6th and 7th boards into place, using 40mm screws, ensuring to fix through the roof board into the truss below.

90x40mm Screws

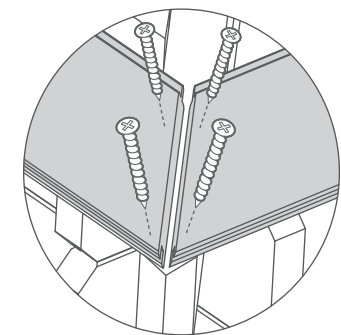

IMPORTANT: Pre-drill before fixing screws.

Roof Assembly 1

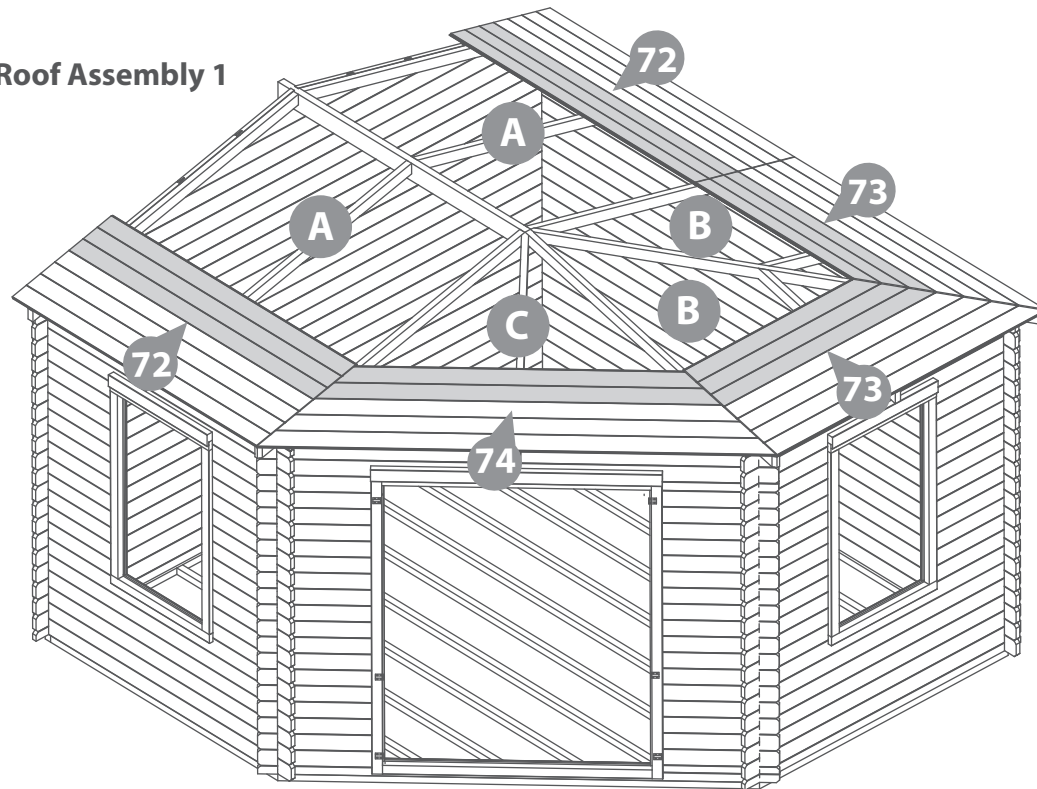

Roof Assembly 2

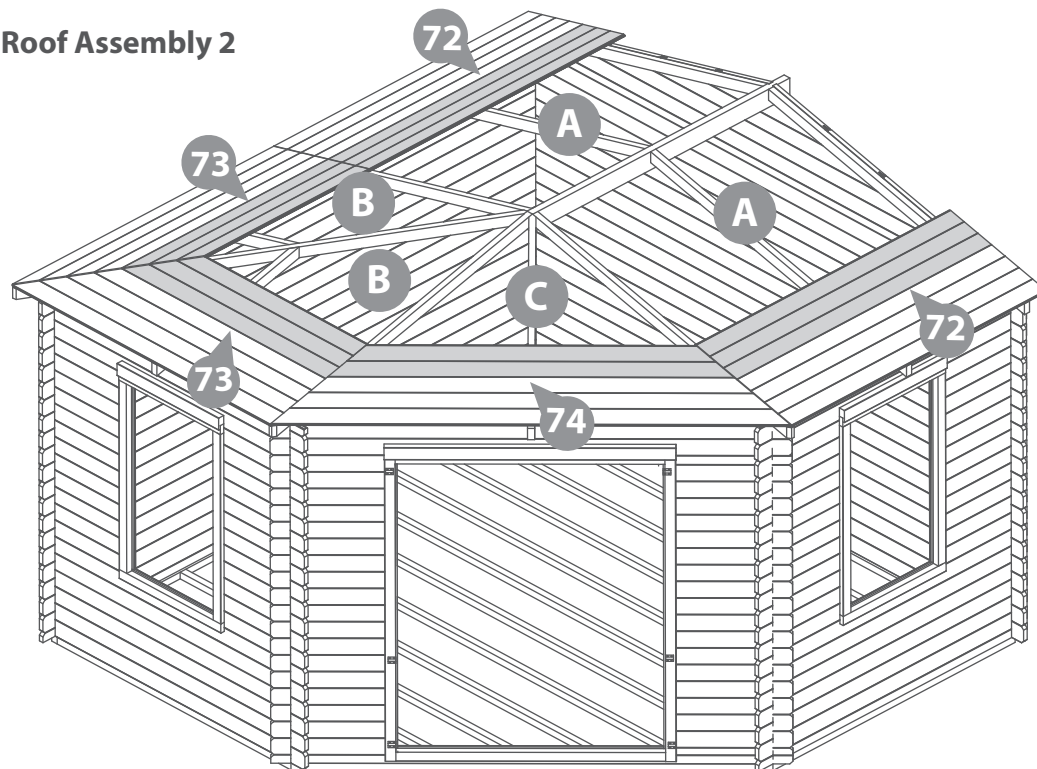

Step 31
Parts needed - No. 72
No. 73
No. 74

***HINT: keep the roof board packs separate so they do not get mixed up.**

Continue arranging the roof board packs (A, B, & C) onto the log cabin, working around the structure, building each layer of roof boards one by one.

Use the spacer (No.70) to create an expansion gap between each roof board if installing during low levels of moisture (summer). This creates an expansion gap for the boards to move into during high levels of moisture (winter).

Once you are happy with the fit of the roof boards, fix the 8th, 9th & 10th boards into place using 40mm screws, ensuring to fix through the roof board into the truss below.

90x40mm Screws

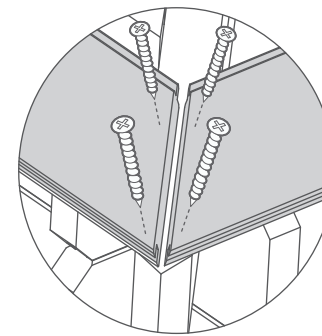

IMPORTANT: Pre-drill before fixing screws.

Roof Assembly 1

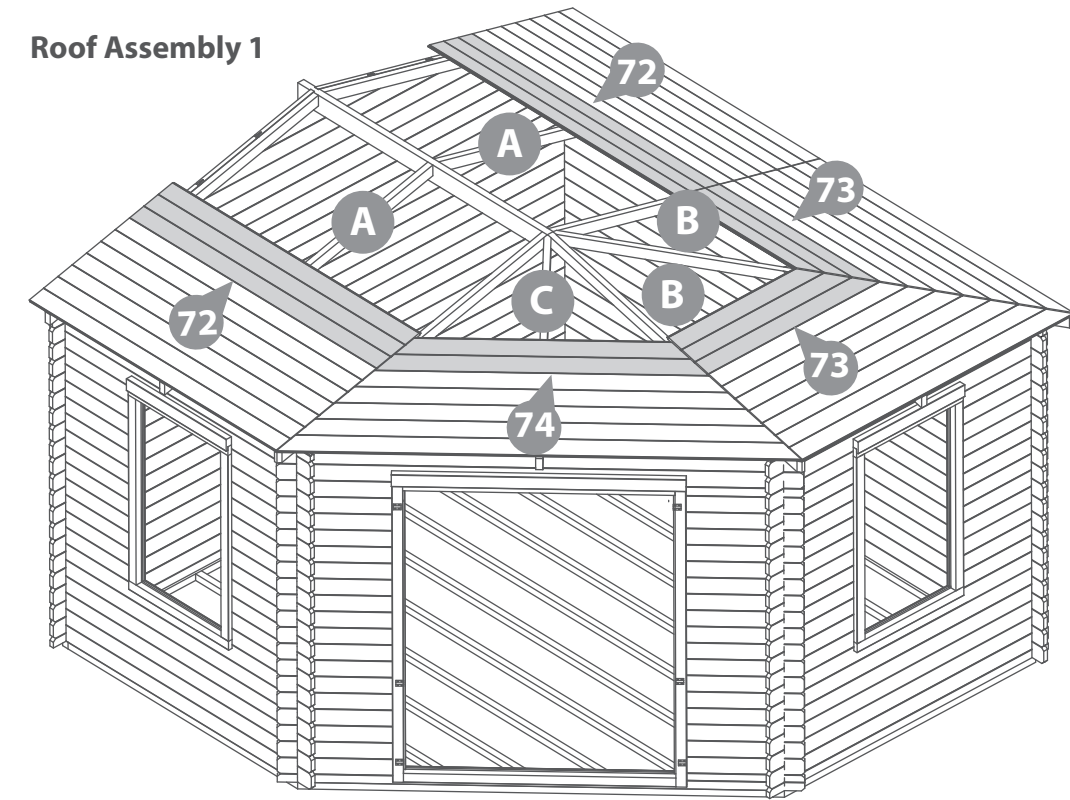

Roof Assembly 2

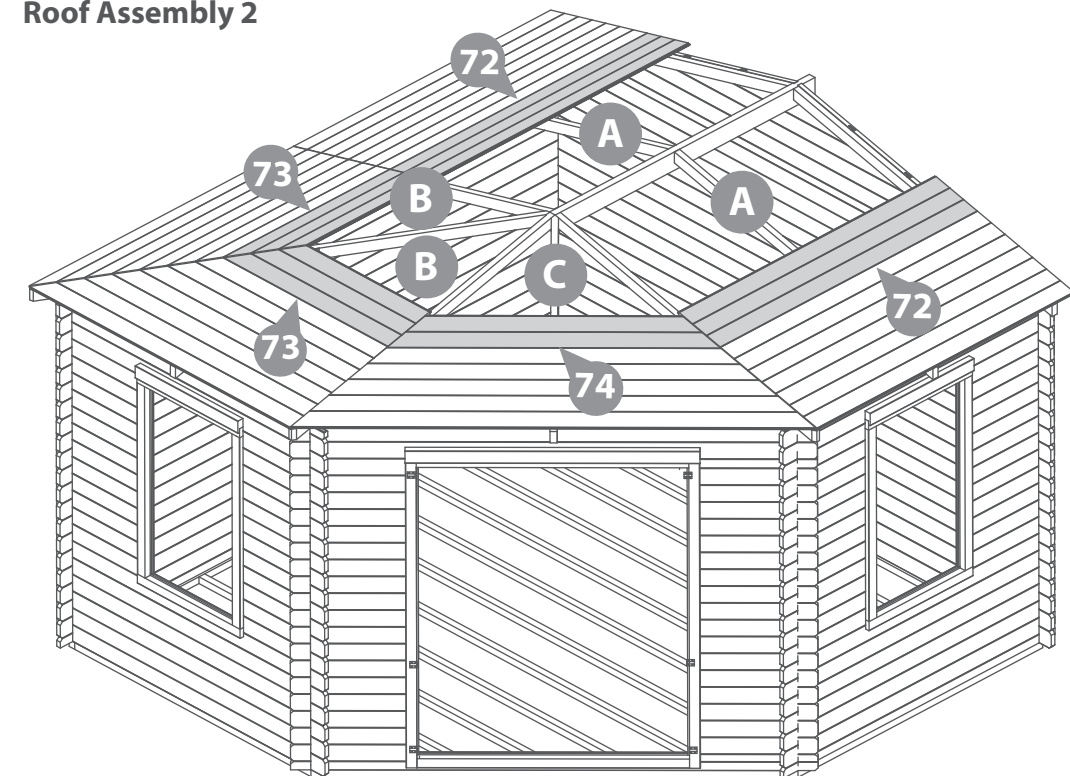

Step 32

Parts needed - No. 72
No. 73
No. 74

***HINT: keep the roof board packs separate so they do not get mixed up.**

Continue arranging the roof board packs (A, B, & C) onto the roof assembly, working around the structure, building each layer of roof boards one by one.

Use the spacer (No.70) to create an expansion gap between each roof board if installing during low levels of moisture (summer). This creates an expansion gap for the boards to move into during high levels of moisture (winter).

Once you are happy with the fit of the roof boards, fix the 11th, 12th, 13th and 14th boards into place using 40mm screws, ensuring to fix through the roof board into the truss below.

120x40mm Screws



40mm screw

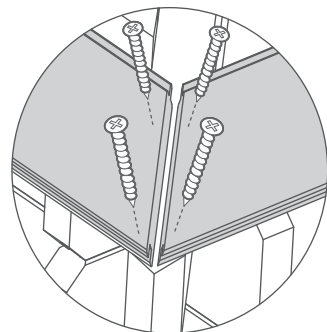

Roof Assembly 1

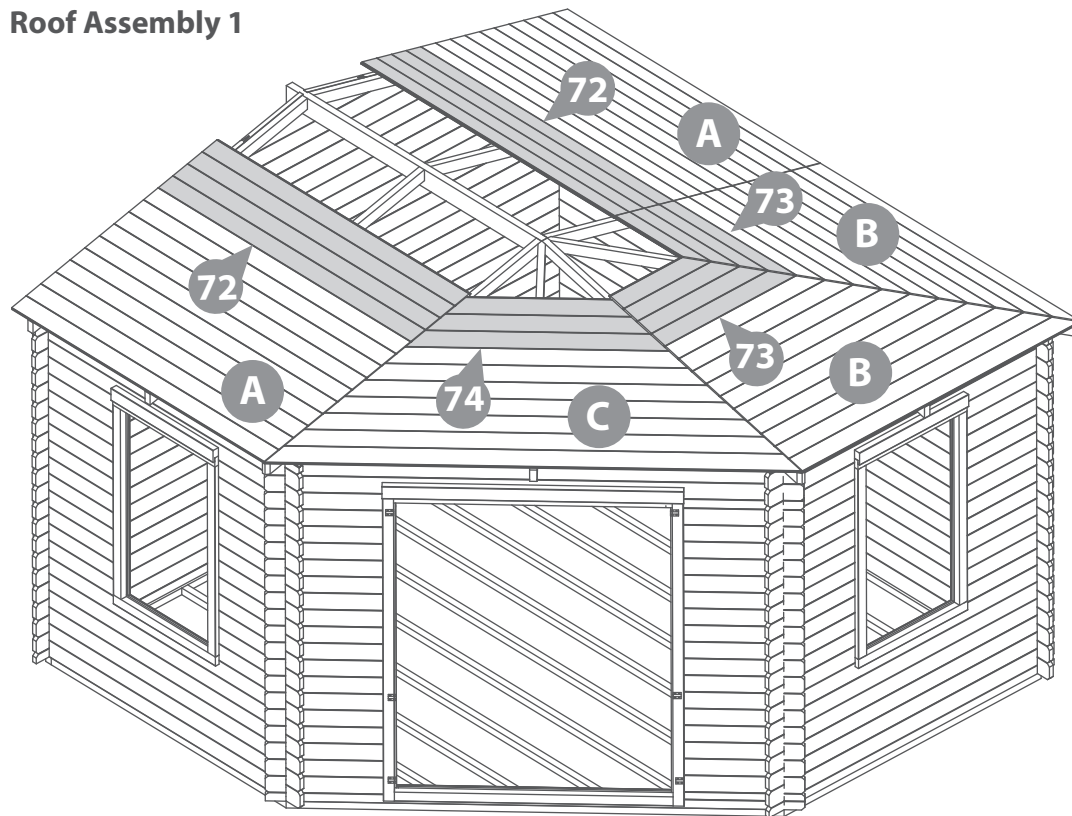

IMPORTANT: Pre-drill before fixing screws.

Roof Assembly 2

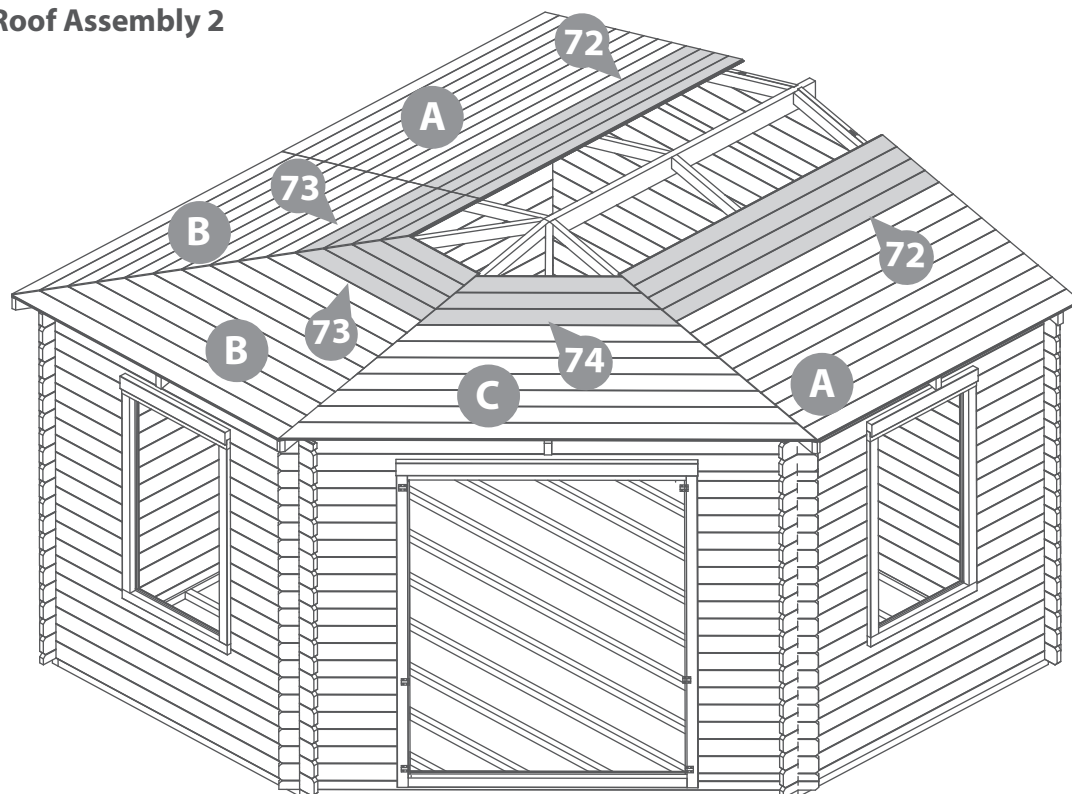

Step 33

Parts needed - No. 72
No. 73
No. 74

***HINT: keep the roof board packs separate so they do not get mixed up.**

Arrange the remaining roof boards (A, B, & C) onto the roof assembly, working around the structure, building each layer of roof boards one by one.

Use the spacer (No.70) to create an expansion gap between each roof board if installing during low levels of moisture (summer). This creates an expansion gap for the boards to move into during high levels of moisture (winter).

The last two boards from Pack A will overhang. Using a pencil and a straight edge, mark out the line as a guide.

Cut along the pencil mark and remove the excess. Place the cut down board's back onto the roof.

Once you are happy with the fit of the roof boards, fix the remaining boards into place using 40mm screws, ensuring to fix through the roof board into the truss below.

150x40mm Screws



Pre drill hole

40mm screw

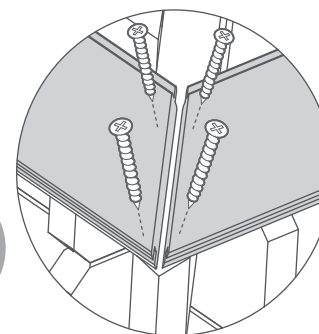

IMPORTANT: Pre-drill before fixing screws.

Roof Assembly 1

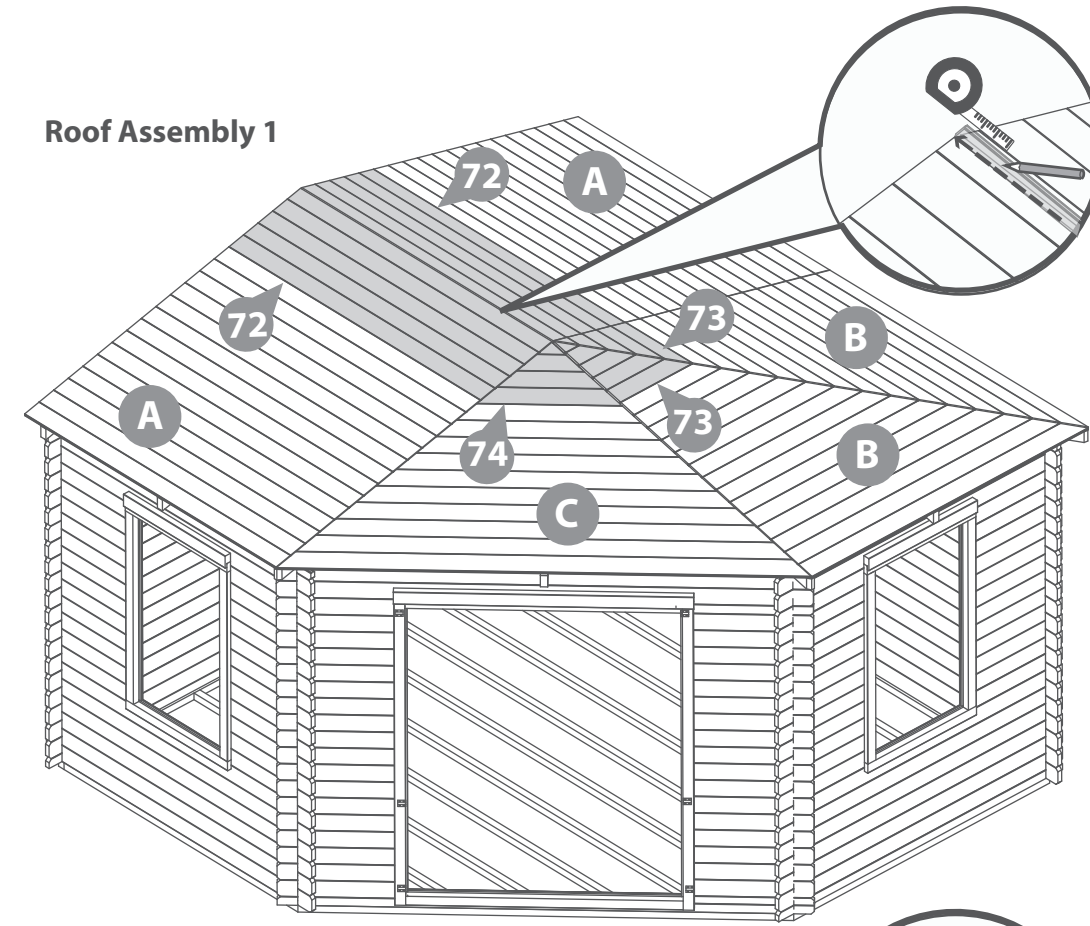

Roof Assembly 2

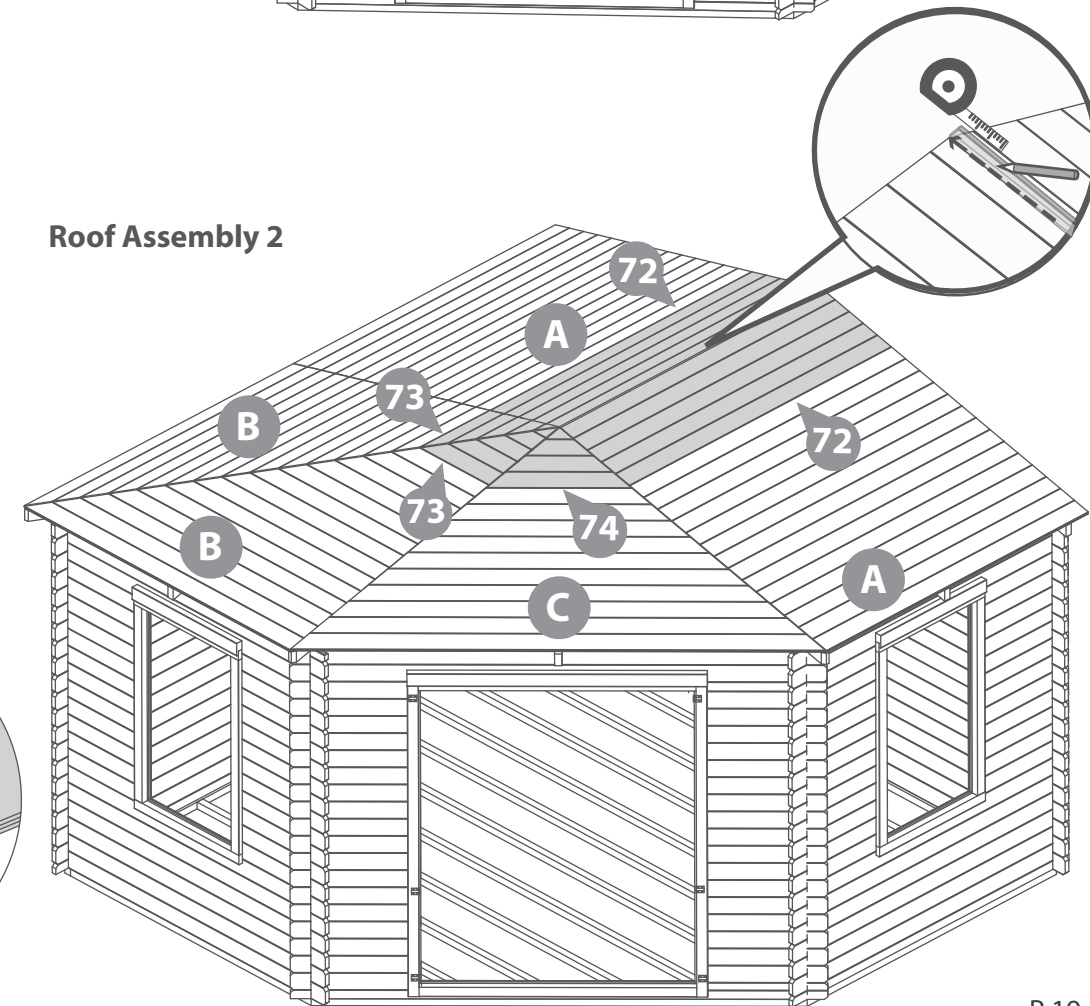

Step 34

Lift each window onto the already existing hooks on the window frame, ensuring the hook and bands connect.

***Some adjustment may be required to align properly.**

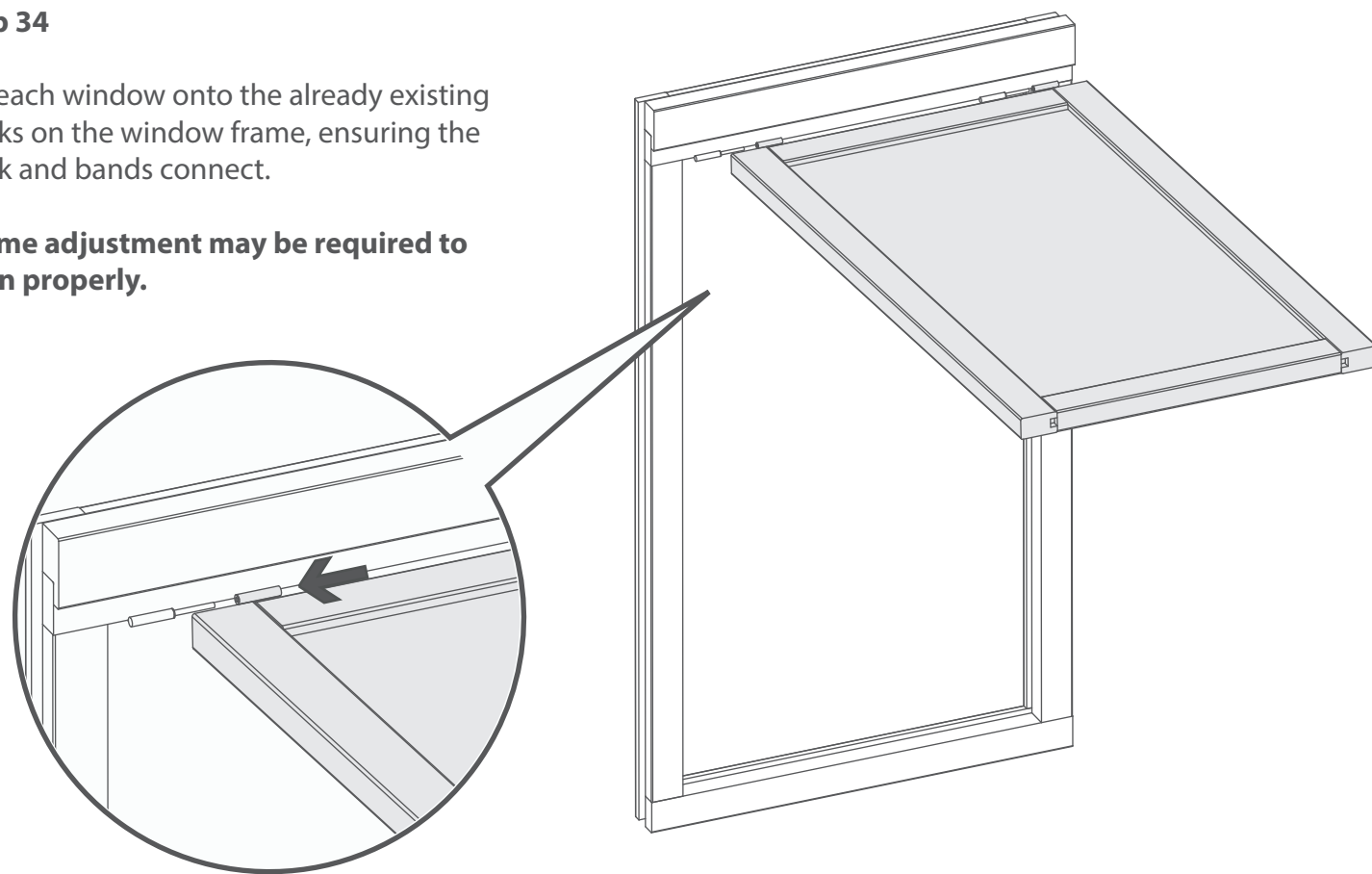

Step 36

Lift each door onto the already existing hooks on the door frame, ensuring the hook and bands connect.

***Some adjustment may be required to align properly.**

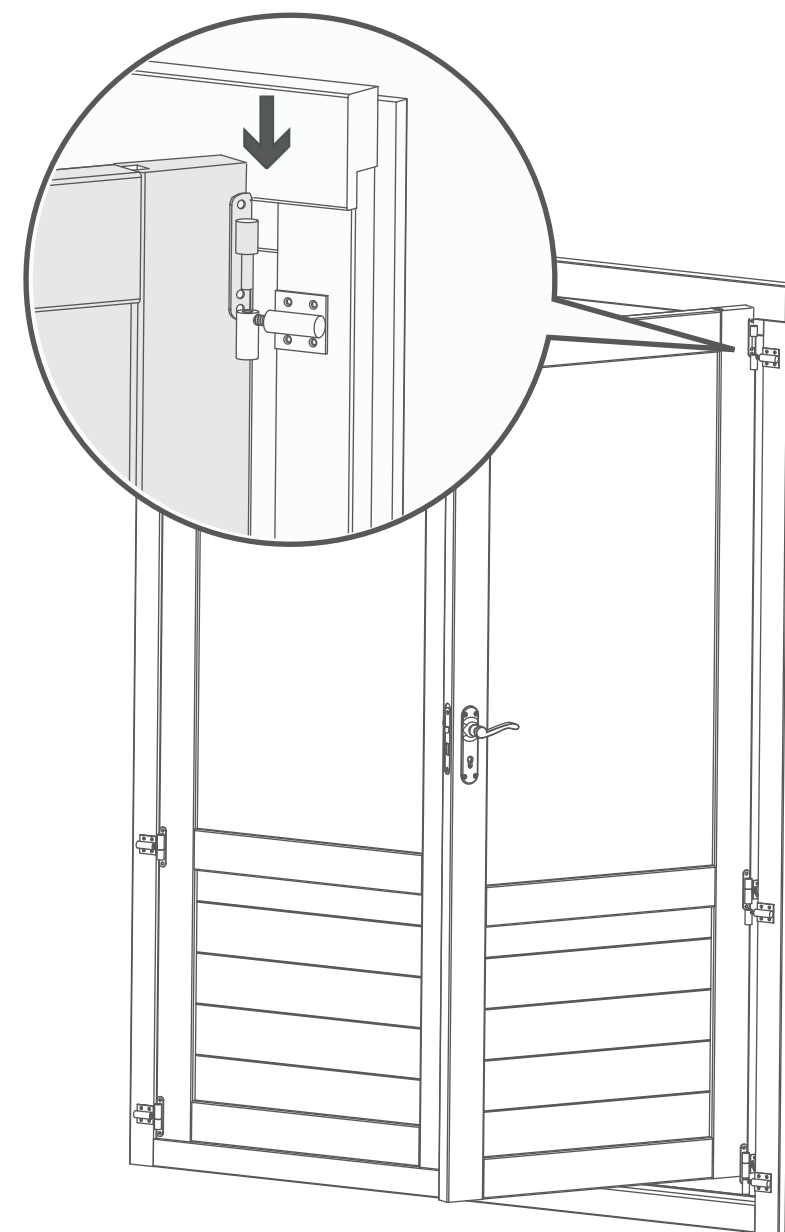

Step 35

Parts Needed - No. 8 QTY 2

Fix the casement stay (**No. 8**) onto the window (**No. 1**) and the casement stay pins to the window framing using 6x30mm screws.

***Ensure the casement stay is centralised on the window.**

Use this method to fit the casement stays to both the windows.

12x30mm Screws



30mm screw

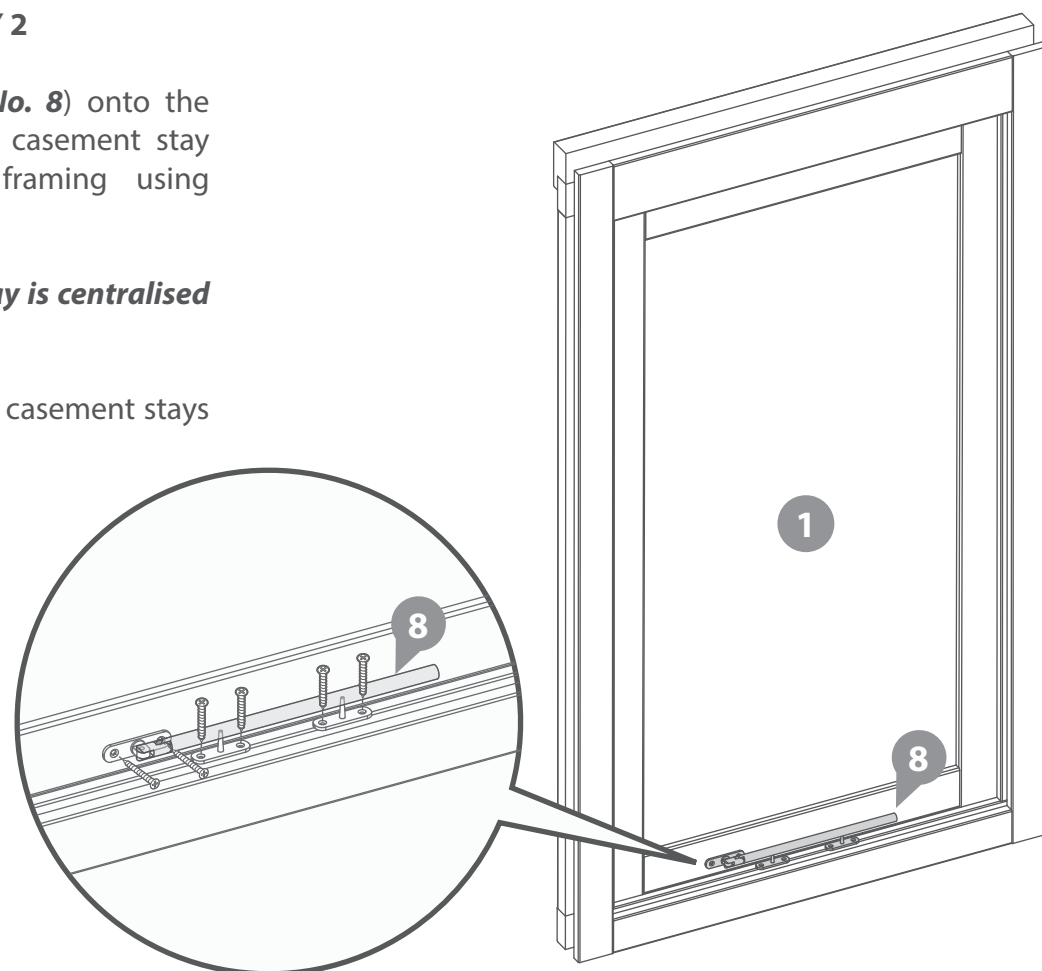

Step 37

Parts Needed - No. 18 QTY 1
No. 19 QTY 1
No. 20 QTY 1

IMPORTANT: Pre-drill before fixing screws.

a Fit the Mortice lock (**No. 19**) into the recess in the master door (**No. 9**) and secure using the screws provided. Attach the Key plate (**No. 20**) to the slave door (**No. 10**) with 4x30mm screws.

b Fit the door handles (**No. 18**) and connect with the metalbar to the mortice lock using 8x30mm screws. Ensure the lock mechanism closes correctly. If not, remove the lock and turn the catch around using the small grub screw.

**Please note: This image is for illustrative purposes and may differ from your choice in product (regarding ironmongery). Nevertheless the process of fixing the frames is the same. Once components have been fitted, try closing doors to ensure the doors can be closed and the lock works.*

If your doors do need adjusting please look at step 34 if not proceed to step 36..

12x30mm Screws

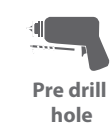

Pre drill hole

30mm screw

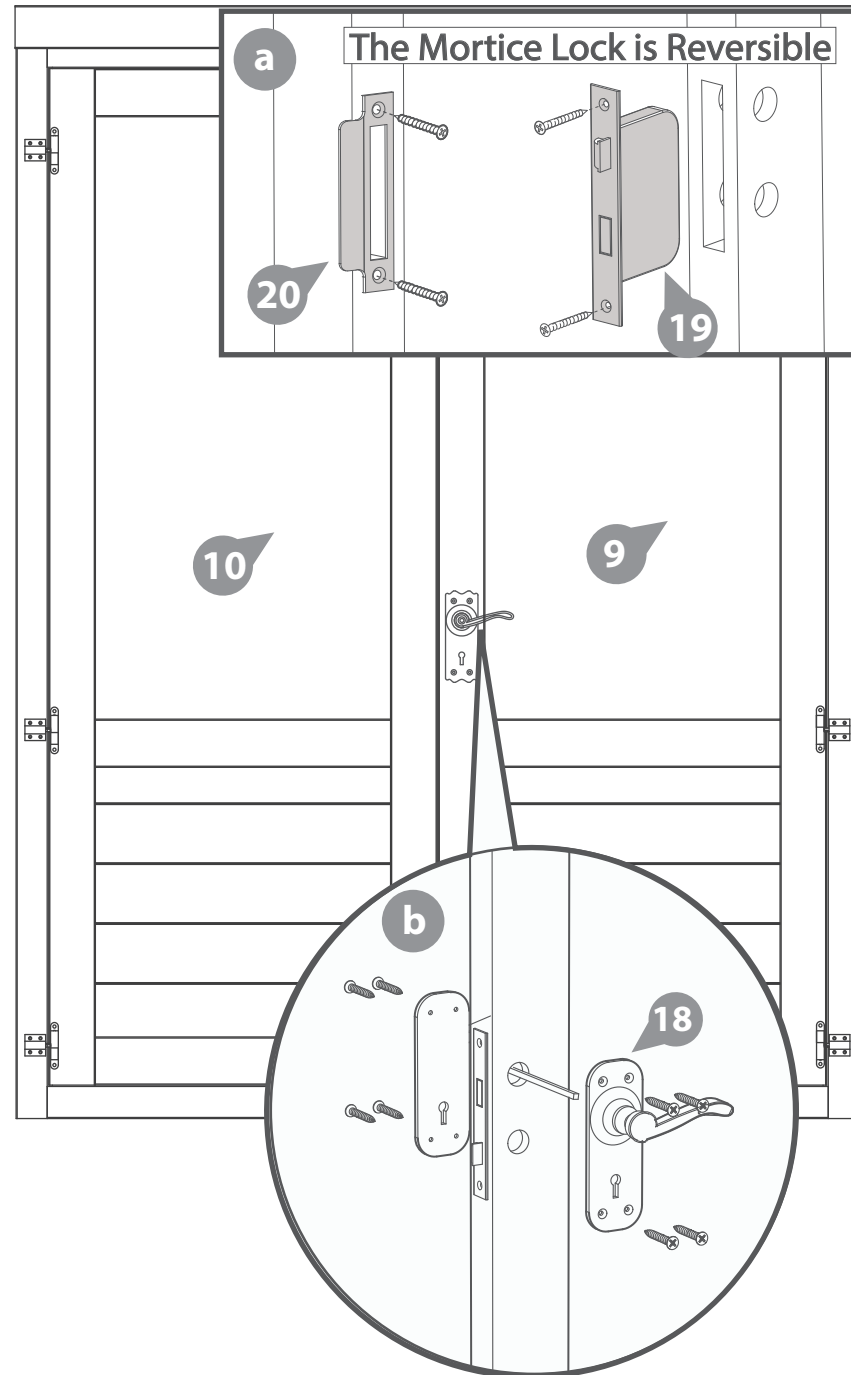

Step 38

Parts Needed - No. 15 QTY 1
No. 21 QTY 2

IMPORTANT: Pre-drill before fixing screws.

a Attach the door strip (**No. 15**) to the back of slave door using 4x40mm screws as shown in the illustration.

b Once fixed, place the Tower Bolts (**No. 21**) roughly into position and with a pencil mark around the bolt.

c After marking the bolt onto the frame, drill a hole for the barrel bolt to locate into.

d Following the hole being drilled, place the tower bolts into position and secure using the screws provided.

12x40mm Screws



Pre drill hole

40mm screw

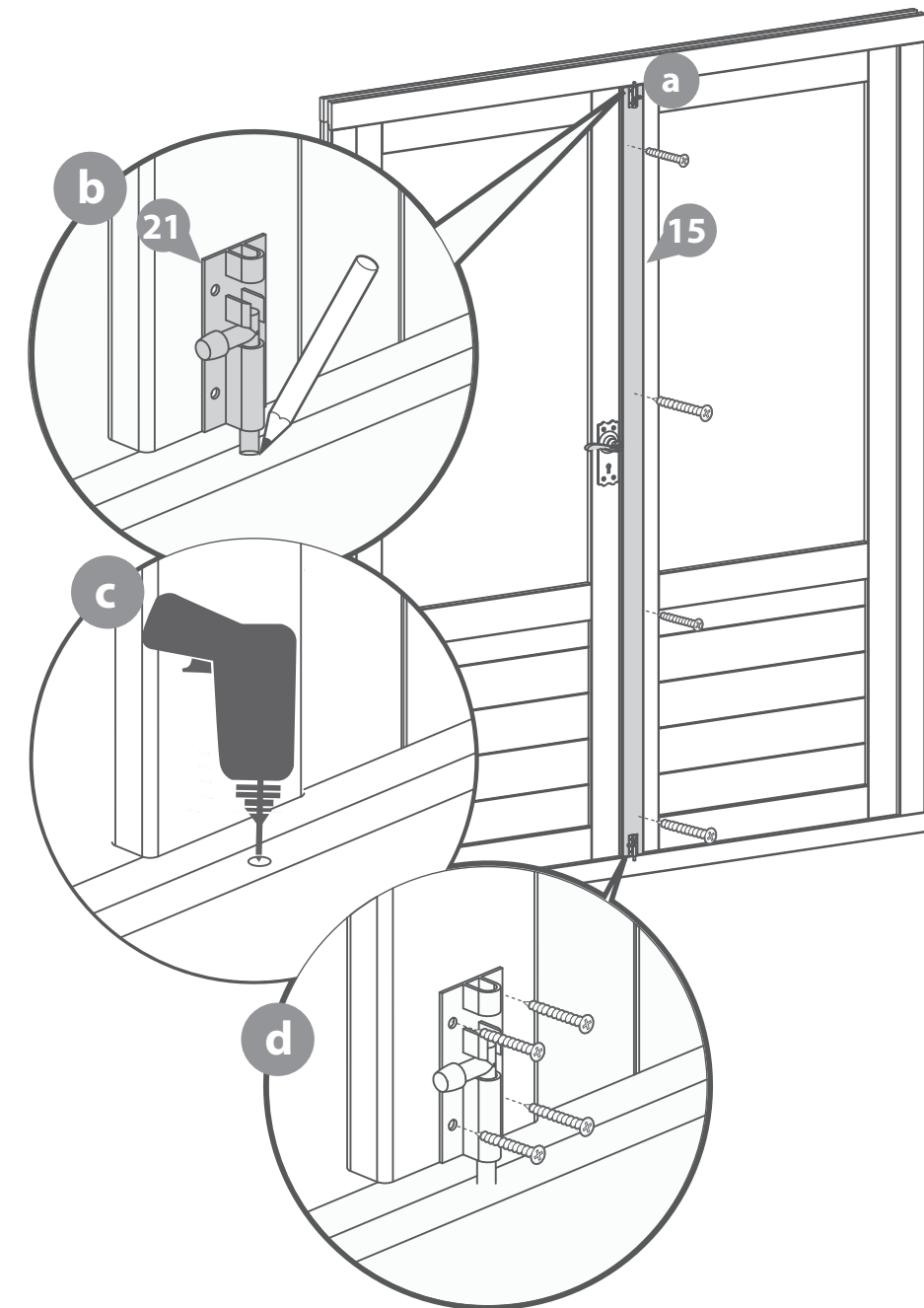

Step 39
Parts needed - No. 69

Measure and cut the felt (**No. 69**) using the dimensions given below as a guide. Cutting Strips 9-10 from the off-cuts of strips 1-8.

Lay the first piece of felt (**1- 2098mmX1000mm**) onto the roof as shown (**1**) and cut down to the individual triangle shape of the roof.

Continue this method for each piece of felt (**2-11**) in the order as shown, ensuring a 50mm overlap between each piece.

Secure along the outer edge of each felt section using felt tacks spaced out at approximately 100mm intervals.

**Ensure there is 50mm of overhanging felt around the base of the roof.*

600x Felt Tacks



Felt sheet dimensions:

- 1 - 2098mm (L) x 1000mm (W)
- 2 - 3004mm (L) x 1000mm (W)
- 3 - 2150mm (L) x 1000mm (W)
- 4 - 4152mm (L) x 1000mm (W)
- 5 - 2098mm (L) x 1000mm (W)
- 6 - 1310mm (L) x 1000mm (W)
- 7 - 1280mm (L) x 1000mm (W)
- 8 - 3280mm (L) x 1000mm (W)
- 9 - 2098mm (L) x 660mm (W)
- 10 - 522mm (L) x 530mm (W)
- 11 - 2520mm (L) x 660mm (W)

IMPORTANT: Pre-drill before fixing screws.

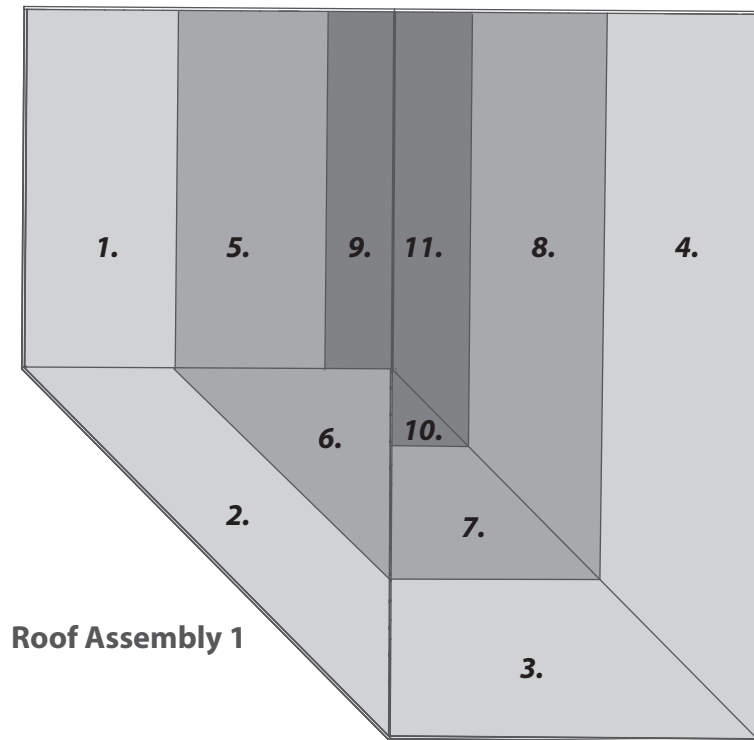

Roof Assembly 1

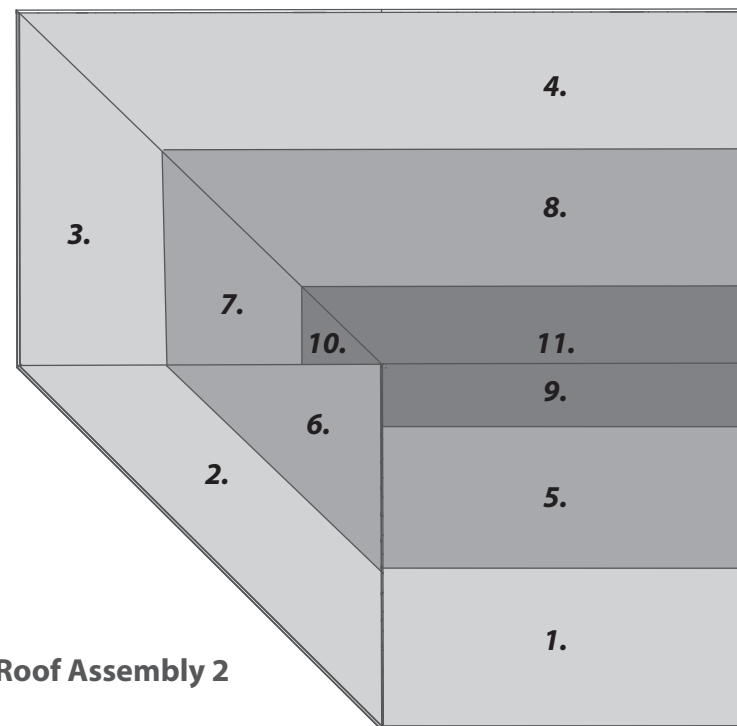

Roof Assembly 2

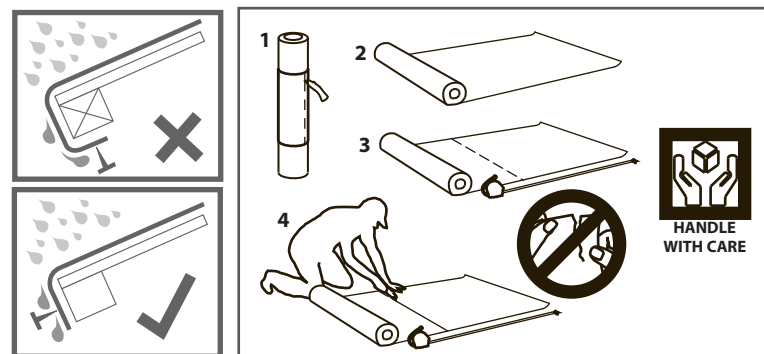

Step 40
Parts needed - No. 69

Measure and cut the remaining felt (**No.69**) using the dimensions given below.

Lay the first strip (**1- 2098mmX200mm**) onto the roof as shown (**1**), ensuring it is overlapping the previously placed sheets.

Continue this method for each of the felt strips (**1-4**)

Secure along the outer edge of each felt section using felt tacks spaced out at approximately 100mm intervals.

250x Felt Tacks



Felt strip dimensions:

- 1 - 2098mm (L) x 200mm (W)
- 2 - 3051mm (L) x 200mm (W)
- 3 - 2220mm (L) x 200mm (W)
- 4 - 2220mm (L) x 200mm (W)

IMPORTANT: Pre-drill before fixing screws.

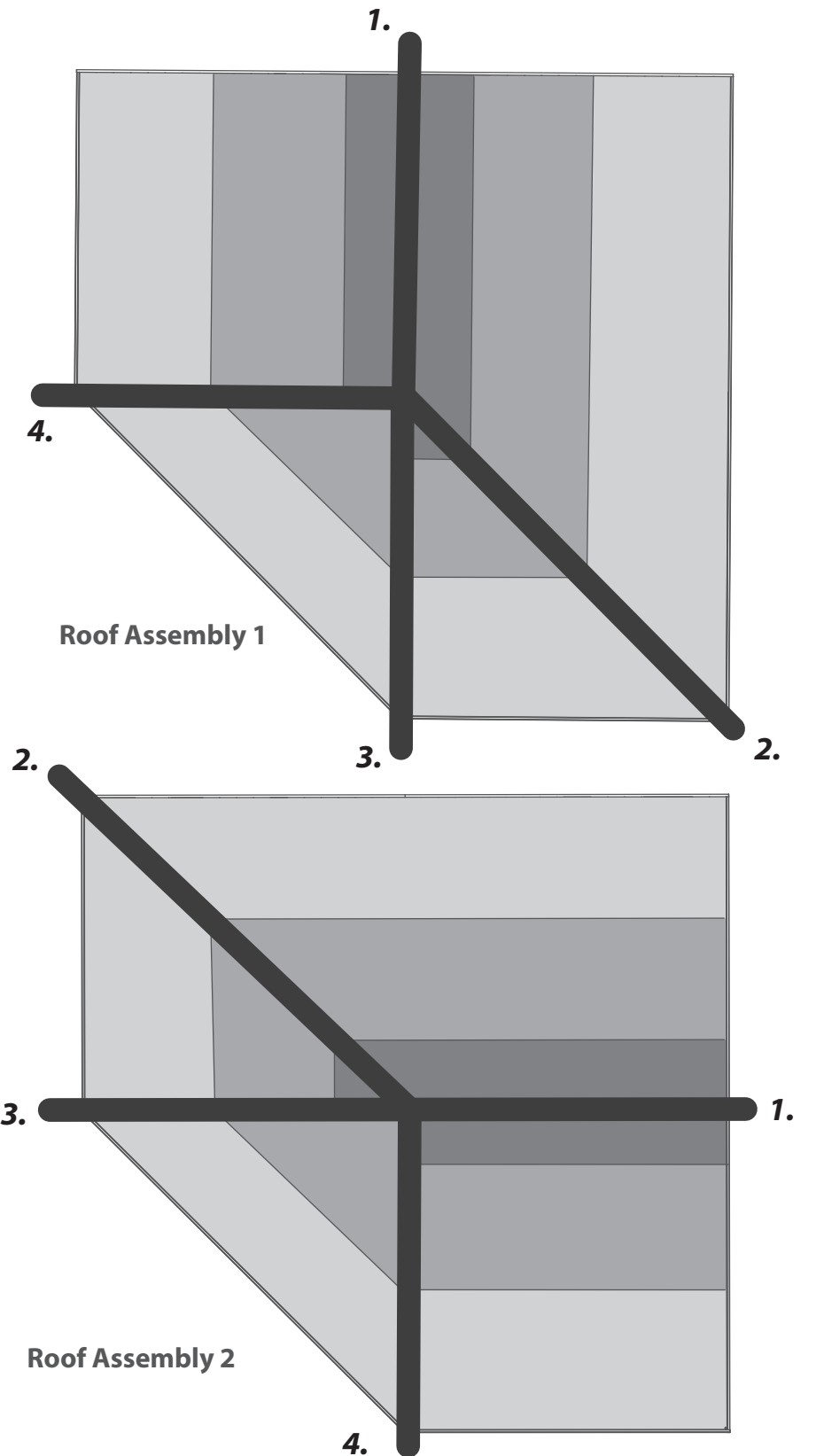

Roof Assembly 1

Roof Assembly 2

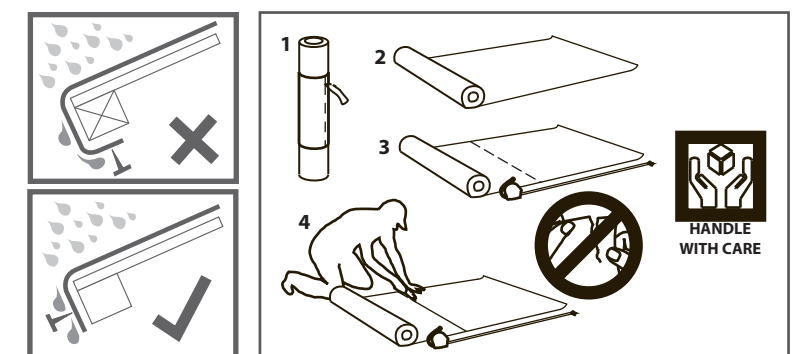

Step 41
Parts needed - No. 71

Place the floor boards (**No. 71**) inside the building flush to the log board on one side.

Continue adding the floor boards (*internally*) making sure to interlock each individual board.

Following the same method outlined previously measure the gap between the bottom of the tongue (**on the last board placed**) and the log board.

Using a straight edge mark out the measurement onto the last floor board (**No. 71**) and cut along the length removing the excess.

****Please note:** Mark the final board 2mm under the measurement; This will allow the timber to expand and contract correctly.

Once all the floor boards are in position secure each board into position using 8x40mm screws per board.

*****Please Note:** Ensure to screw through each of the floor boards into the floor bearers.

280x40mm Screws

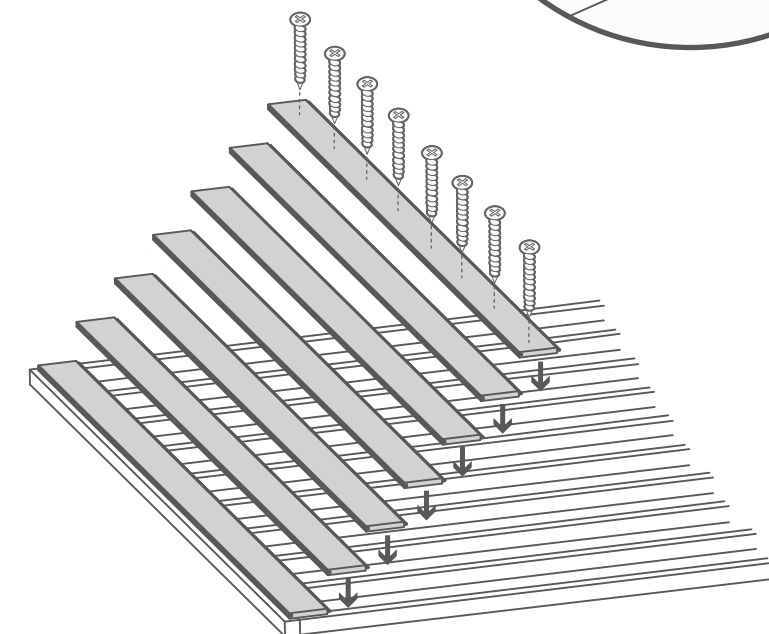
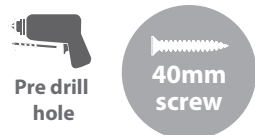

IMPORTANT: Pre-drill before fixing screws.

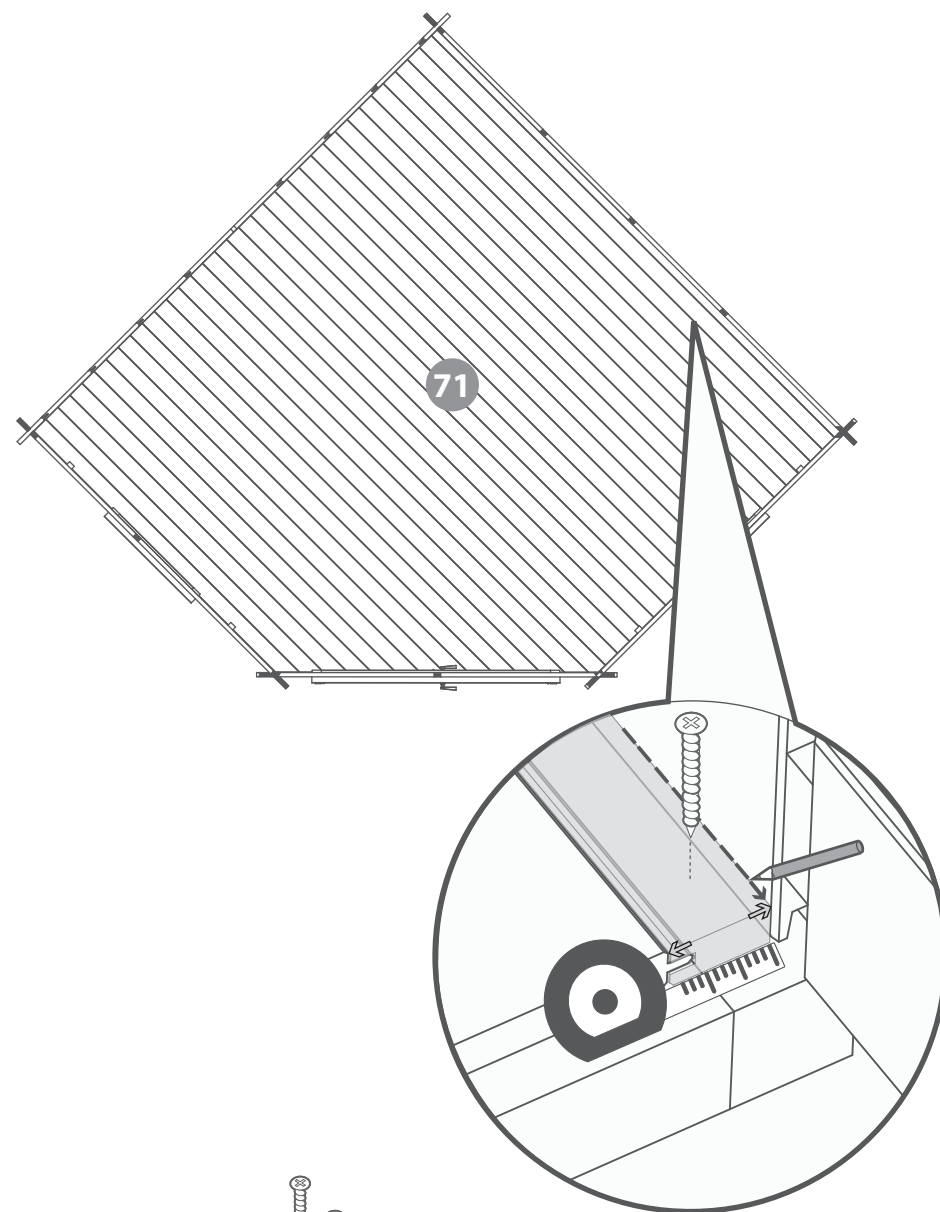

This is for illustrative purposes only and may differ from your floor.

Step 42
Parts needed - No. 68 QTY 7

Inside the building place the closure trim (**No. 68**) against the boarding and align with the roof as shown in the illustration.

***Measure and cut the closure trims to fit the internal space.**

Once in position fix each trim into place by pre drilling a pilot hole and using 6x30mm screws per trim, equally spacing them along the face of the board.

42x30mm Screws



Step 43
Parts needed - No.68 QTY 7

Once the floor has been laid arrange the closure trim (**No. 68**) around the outside edge of floor (*internally*), measure and cut down accordingly to best match the internal space.

Secure each trim section into place using 6x30mm spaced equally along the board as shown in the illustration.

***Do NOT fix the closure trim to the floor boards.**

42x30mm Screws

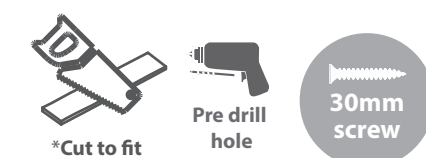

IMPORTANT: Pre-drill before fixing screws.

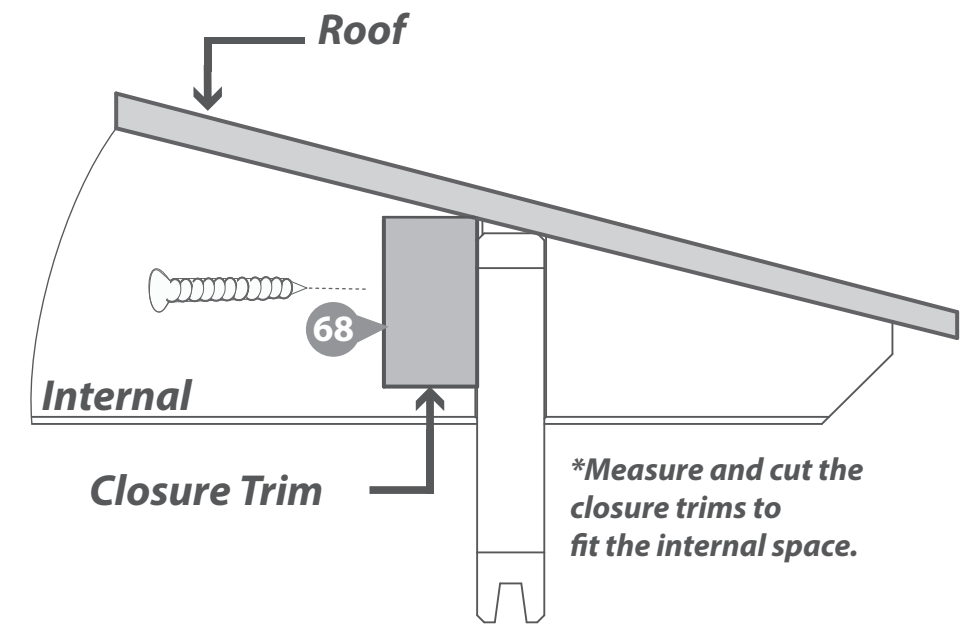

***Measure and cut the closure trims to fit the internal space.**

IMPORTANT: Pre-drill before fixing screws.

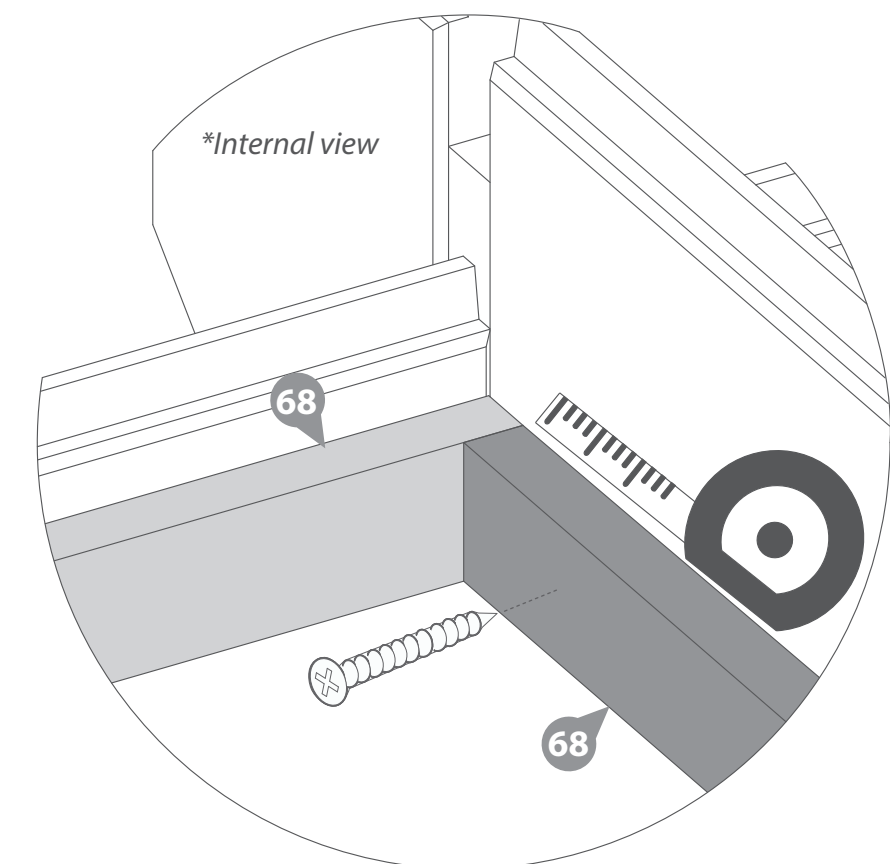

Step 44

- Parts needed - No. 63 QTY 1**
No. 64 QTY 1
No. 65 QTY 2
No. 66 QTY 2

Attach the first fascias (**No.63 & 66**) to the back sides of the log cabin, ensuring to trap the felt between the fascia and the building.

Secure the fascia into position using 40mm screws, making sure to fix through the fascia into the roof purlin, fascia block and/or log boards.

Once in place, mark the excess fascia with a pencil and then trim the fascias to follow the shape of building as shown in the illustration.

Attach the rest of the fascias (**No. 64 & 65**) to the front sides of the log cabin and cut to size in the same way as previously stated.

42x40mm Screws

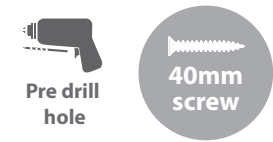

IMPORTANT: Pre-drill before fixing screws.

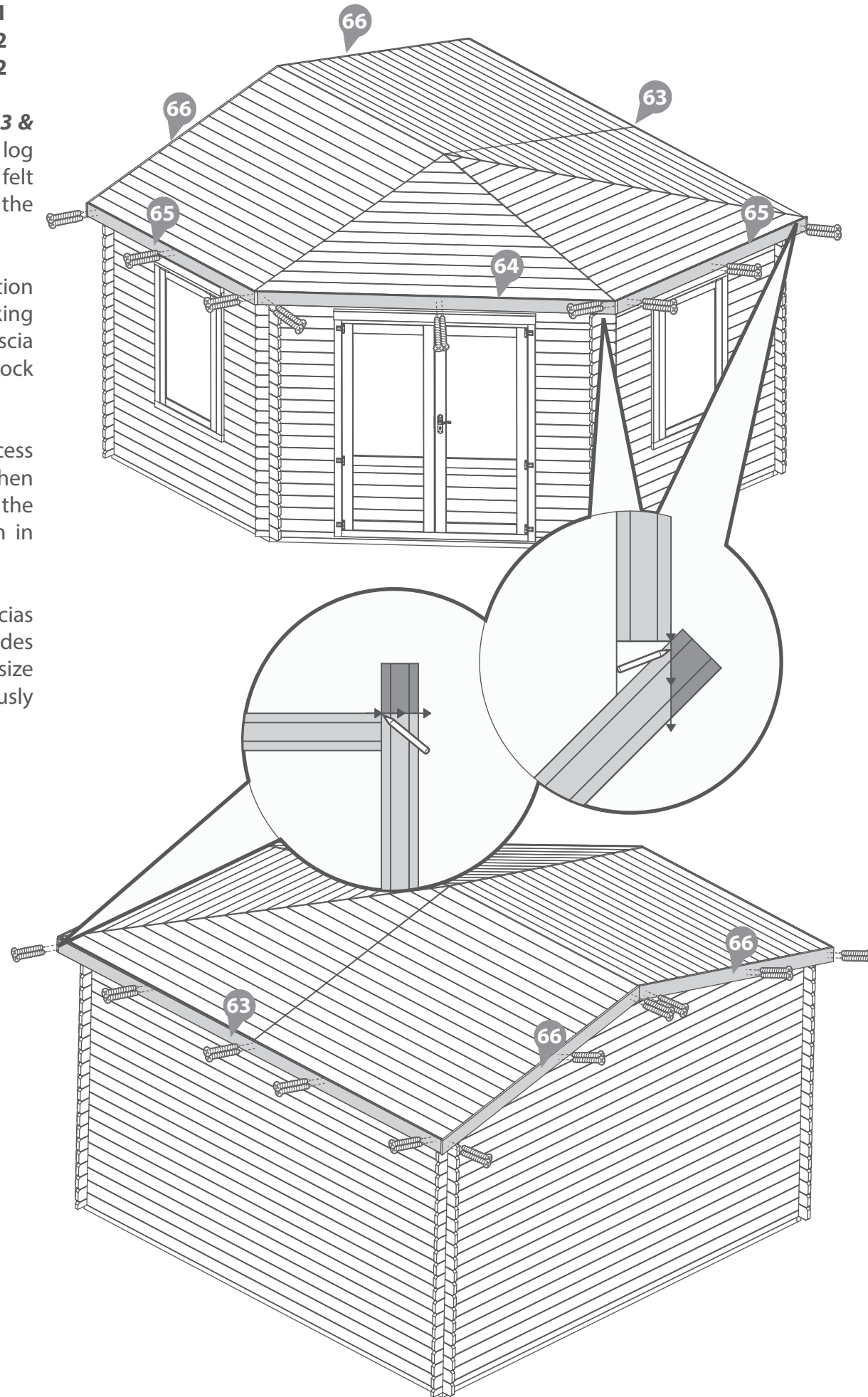

Step 45

- Parts needed - No. 67 QTY 10**

Arrange the storm braces (**No. 67**) around the building (*internally*). Place 2x storm braces per side fixing into place using 2x 70mm bolts per brace making sure the washer & nut are tightened from the outside of the building.

***Ensure the storm braces are secured at the highest point possible on each side.**

The storm braces will need to be altered during the buildings life as the moisture content within the log boards changes. The boards will expand during periods of high moisture (Winter) and shrink during periods of low moisture (Summer.)

****Storm braces will help your building expand and contract properly.**

*****It is important that each bolt is tightened using a washer so as not to damage the log boards.**

20x70mm Bolt Sets

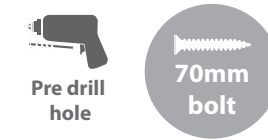

IMPORTANT: Pre-drill before fixing screws.

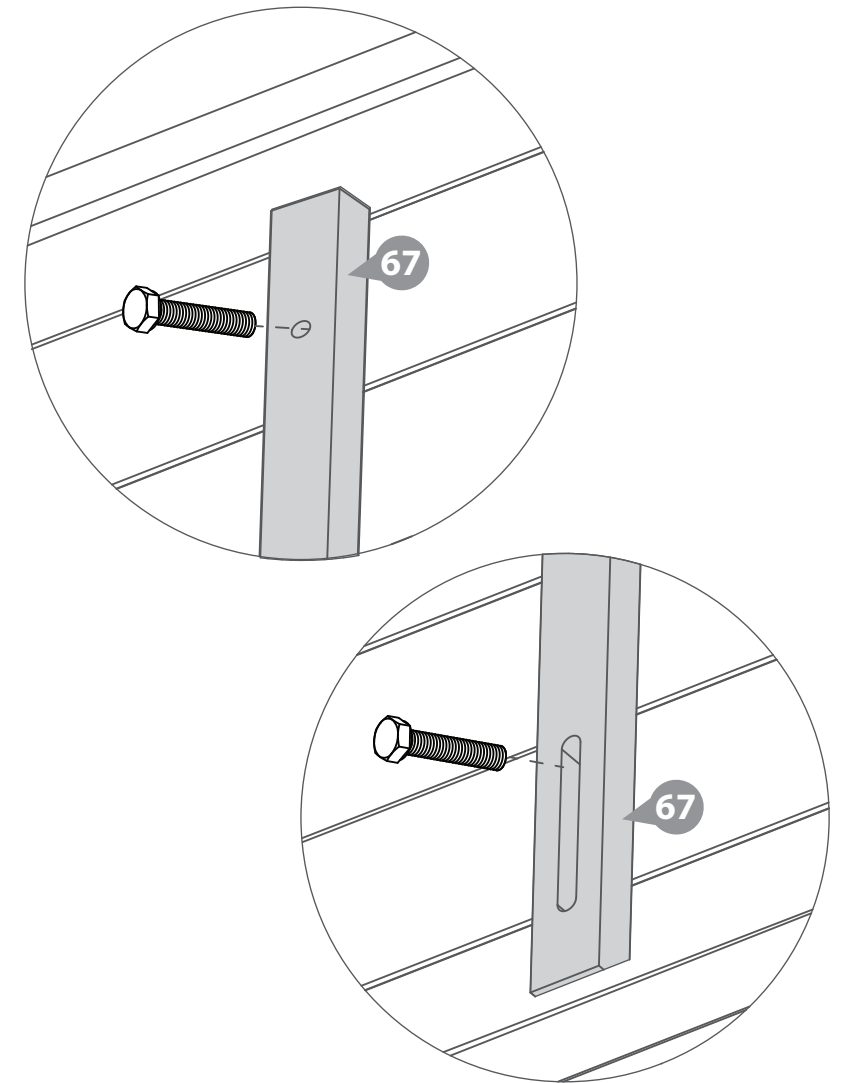

Step 46
Parts Needed: No. 6 QTY 2
No. 16 QTY 1

Attach the Rain Guards (No.6) to the window frame, fixing in place onto the framing above each window using 3x70mm screws per guard.

Attach the Rain Guard (No.16) to the door frame, fixing in place onto the framing above the Door using 3x70mm screws.

9x70mm Screws.

