

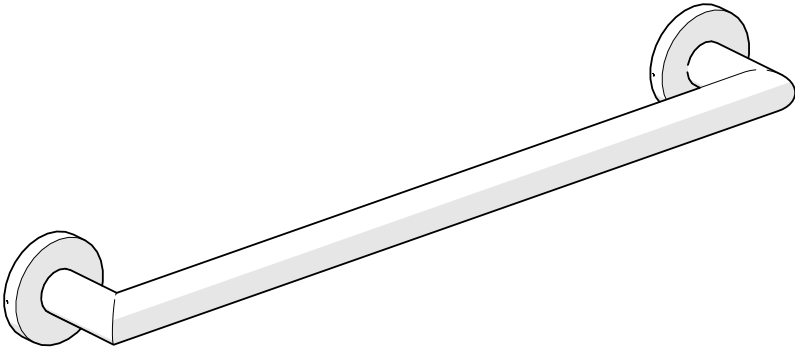

AP506105
AP506205
AP506305
AP506405

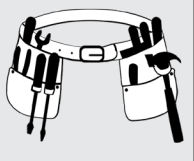

EN. Please read the information sheet before proceeding. **FR.** S'il vous plaît lire la fiche d'information avant de poursuivre. **POL.** Proszę przeczytać ulotkę informacyjną przed przejściem. **DE.** Bitte lesen Sie das Informationsblatt, bevor Sie fortfahren. **ES.** Lea la hoja de información antes de comenzar. **IT.** Leggete la scheda delle informazioni prima di procedere.

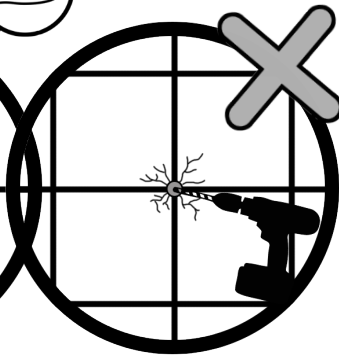
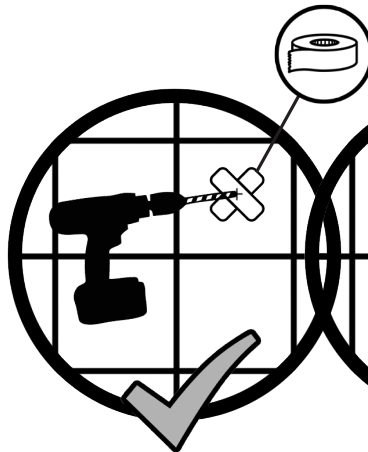
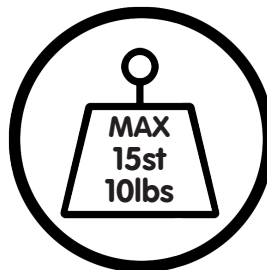
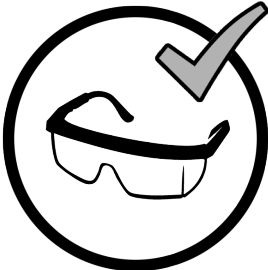

 Croydex, Central Way, Andover, Hampshire, SP10 5AW, UK

 +44 (0) 1264 365881

 +44 (0) 1264 356437

 info@croydex.co.uk

 www.croydex.com

S&H 066 R01

Icon Library (EN)

Modern Grab Bar (EN)



For reference only



Parts may vary.
(Optional)



Warning! Please take special care.

Please read all of the information carefully and refer back when you see the numbered icons throughout instructions.

Safety and Care (EN)

- 1 Always take care when using power tools, particularly if there is any water in the working area.
- 2 For different wall types you will need to ensure that you are using the correct type of fixing for the material of the wall. Wall fixings are not supplied with this product.
- 3 This product must only be fitted to solid brick, concrete block walls or similarly strong materials offering appropriate support for the maximum safe working load.
- 4 When drilling into a tiled surface do not use a hammer drill.
- 5 Always use a drill bit that is suitable for the surface that is being drilled.
- 6 To retain the best quality finish, clean product regularly with a soft damp cloth.
- 7 Do not use abrasive or chemical cleaners, as these will damage the product.
- 8 The maximum safe working load for the product is 100kg distributed evenly.

Bibliothèque d'icônes. (FR)

Poignée (FR)



À titre indicatif
uniquement.



Les pièces peuvent
varier.



Avertissement ! Faites
très attention.

Veillez lire attentivement toutes les informations et vous reporter à la signification des icônes numérotées lorsque vous les rencontrez au fil des instructions.

Sécurité et prudence (FR)

- 1 Soyez toujours vigilants lorsque vous utilisez des outils électriques, notamment en présence d'eau dans l'espace de travail.
- 2 En présence de différents types de mur, vous devrez veiller à utiliser le bon type de fixation pour le matériau du mur. Les fixations murales ne sont pas fournies avec ce produit.
- 3 Ce produit doit être fixé uniquement à des murs en parpaing, en brique pleine ou autres matériaux robustes similaires offrant un support approprié pour la charge maximale d'utilisation.
- 4 N'utilisez jamais de marteau perforateur pour percer une surface carrelée.
- 5 Utilisez toujours une mèche adéquate pour la surface à percer.
- 6 Pour conserver une finition optimale, nettoyez régulièrement le produit avec un chiffon doux humide.
- 7 N'utilisez pas de nettoyants abrasifs ou chimiques car ils pourraient endommager le produit.
- 8 La charge maximale d'utilisation pour le produit est de 100kg, répartis uniformément.

2.



Croydex, Central Way, Andover,
Hampshire, SP10 5AW, UK



+44 (0) 1264 356437



www.croydex.com



+44 (0) 1264 365881



info@croydex.co.uk

S&H 066 R01

Symbolverzeichnis. (DE)

Griffstange (DE)



Nur als Referenz.



Teile können variieren.



Achtung! Bitte besonders vorsichtig sein.

Bitte lesen Sie sich alle Informationen sorgfältig durch und schlagen Sie nach, wenn Sie die nummerierten Symbole in der Anleitung sehen.

Sicherheit und Pflege (DE)

- 1 ⚠ Elektrowerkzeuge immer mit Sorgfalt verwenden, insbesondere dann, wenn Wasser im Arbeitsbereich vorhanden ist.
- 2 ⚠ Bei verschiedenen Wandarten ist sicherzustellen, dass die richtige Art der Befestigung für das Wandmaterial verwendet wird. Wandbefestigungen werden nicht mit diesem Produkt mitgeliefert.
- 3 ⚠ Dieses Produkt darf nur auf massiven Mauerwerk, Betonformsteinwänden oder ähnlich stabilen Materialien installiert werden, die ausreichenden Halt für die maximale sichere Gebrauchslast bieten.
- 4 ⚠ Beim Bohren in eine Fliesenoberfläche keinen Bohrhämmer verwenden.
- 5 ⚠ Immer einen Bohraufsatz verwenden, der für die Bohroberfläche geeignet ist.
- 6 ⚠ Produkt regelmäßig mit einem weichen, nebelfeuchten Tuch reinigen, um die hochwertige Oberflächenveredelung so gut wie möglich zu erhalten.
- 7 ⚠ Keine abrasiven oder chemischen Reinigungsmittel verwenden, da diese das Produkt beschädigen können.
- 8 ⚠ Die maximale Gebrauchslast für das Produkt liegt bei 100kg, gleichmäßig verteilt.

Biblioteka ikon. (PL)

Uchwyt (PL)



Tylko jako przykład.



Części mogą się różnić.



Ostrzeżenie! Zachować szczególną ostrożność.

Przeczytać ze zrozumieniem wszystkie informacje i korzystać z nich w przypadku numerowanych ikon występujących w treści instrukcji.

Bezpieczeństwo i ochrona (PL)

- 1 ⚠ Zawsze zachować ostrożność podczas korzystania z elektronarzędzi, w szczególności w przypadku ich użycia w obszarze pracy, w którym występuje woda.
- 2 ⚠ Należy upewnić się w przypadku różnych typów ścian, czy posiadane elementy mocujące są przeznaczone do danego typu ściany. Elementy mocujące do ściany nie są dołączone do opakowania produktu.
- 3 ⚠ Niniejszy produkt może być mocowany wyłącznie do ścian z litej cegły lub bloków betonowych lub podobnego wytrzymałego materiału zapewniającego odpowiednie wsparcie w celu zagwarantowania trwałości przy maksymalnym bezpiecznym obciążeniu roboczym.
- 4 ⚠ Podczas wiercenia w powierzchni z płytkami nie należy używać wiertarki udarowej.
- 5 ⚠ Zawsze należy używać wiertła przeznaczonego do powierzchni, która ma zostać nawiercona.
- 6 ⚠ W celu utrzymania najwyższej jakości produktu należy go regularnie czyścić przy użyciu miękkiej, wilgotnej szmatki.
- 7 ⚠ Nie stosować chemicznych środków do czyszczenia o właściwościach ściernych, ponieważ mogą one prowadzić do uszkodzenia produktu.
- 8 ⚠ Maksymalne, bezpieczne obciążenie robocze dla produktu wynosi 100kg w przypadku równomiernego rozłożenia.

3.



Croydex, Central Way, Andover,
Hampshire, SP10 5AW, UK



+44 (0) 1264 356437



www.croydex.com



+44 (0) 1264 365881



info@croydex.co.uk

S&H 066 R01

Icon Library (ES)

Asidero (ES)



Las piezas pueden variar.



Solo como referencia.



¡Atención! Tenga mucho cuidado.

Lea atentamente toda la información y consúltela cuando vea los iconos numerados que aparecen a lo largo de las instrucciones.

Seguridad y mantenimiento (ES)

- 1 Tenga cuidado al utilizar herramientas eléctricas, en especial si hay agua en la zona de trabajo.
- 2 Los tacos suministrados solo se pueden usar en paredes macizas. Si va a trabajar en paredes huecas o de cartón yeso, utilice las fijaciones especiales adecuadas para el tipo de construcción de la pared en cuestión.
- 3 Debe asegurarse de que utiliza el tipo de fijación correcto para el material de la pared en cuestión. Las fijaciones a la pared no se suministran con este producto.
- 4 Al perforar una superficie con recubrimiento cerámico, no utilice un taladro percutor.
- 5 Use siempre una broca adecuada para la superficie que va a taladrar.
- 6 Para conservar su acabado de alta calidad, limpie periódicamente el producto con un paño suave humedecido con agua.
- 7 No emplee productos químicos ni productos de limpieza abrasivos, ya que podrían deteriorar la superficie del producto.
- 8 La carga máxima de trabajo en condiciones seguras del producto es de 100kg distribuidos uniformemente.

Elenco delle icone. (IT)

Maniglione (IT)



I componenti possono variare.



Solo per riferimento.



Attenzione! Prestate particolare attenzione.

Leggete attentamente tutte le informazioni e consultatele quando vedete le icone numerate nelle istruzioni.

Sicurezza e cura (IT)

- 1 Prestate sempre attenzione quando utilizzate utensili elettrici, in particolare in presenza di acqua nell'area di lavoro.
- 2 I tasselli in dotazione sono intesi unicamente per l'utilizzo su pareti piene. Per le intercapedini o il cartongesso, utilizzate dispositivi di fissaggio specialistici, adatti al tipo di parete.
- 3 Per i diversi tipi di pareti dovete assicurarvi di utilizzare il tipo di dispositivo di fissaggio corretto per il materiale della parete. I dispositivi di fissaggio a parete non sono in dotazione con questo prodotto.
- 4 Quando forate una superficie piastrellata, non utilizzate un trapano a percussione.
- 5 Utilizzate sempre una punta per trapano che sia adatta alla superficie da perforare.
- 6 Per mantenere la massima qualità della finitura, pulite il prodotto regolarmente con un panno morbido inumidito.
- 7 Non utilizzate detergenti abrasivi o chimici, dal momento che potrebbero danneggiare il prodotto.
- 8 Il carico di lavoro massimo sicuro per il prodotto è pari a 100kg distribuiti in modo uniforme.

4.



Croydex, Central Way, Andover,
Hampshire, SP10 5AW, UK



+44 (0) 1264 356437



www.croydex.com



+44 (0) 1264 365881



info@croydex.co.uk

S&H 066 R01



EN. Not supplied

FR. Non fourni

DE. Nicht mitgeliefert

ES. No se suministra

IT. Non in dotazione

PL. Nie objęte dostawą

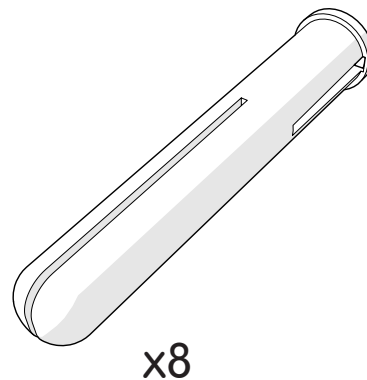
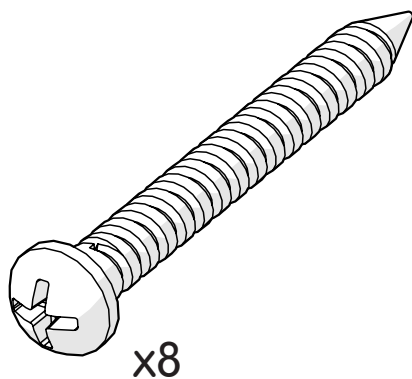

1.

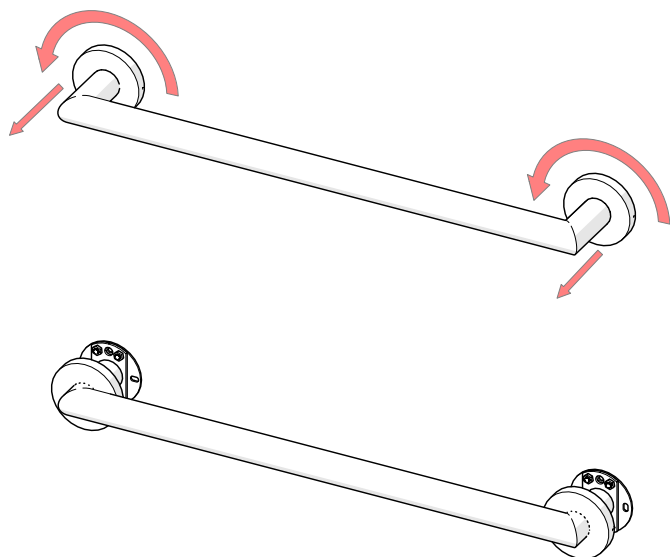

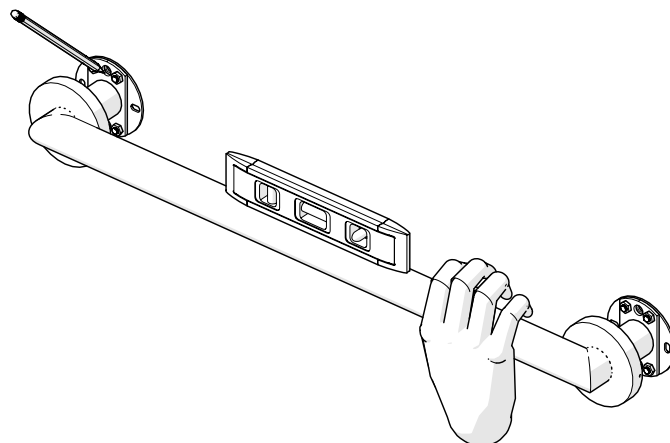

2.



5.

 Croydex, Central Way, Andover,
Hampshire, SP10 5AW, UK

 +44 (0) 1264 365881

 +44 (0) 1264 356437

 info@croydex.co.uk

 www.croydex.com

S&H 066 R01

3.

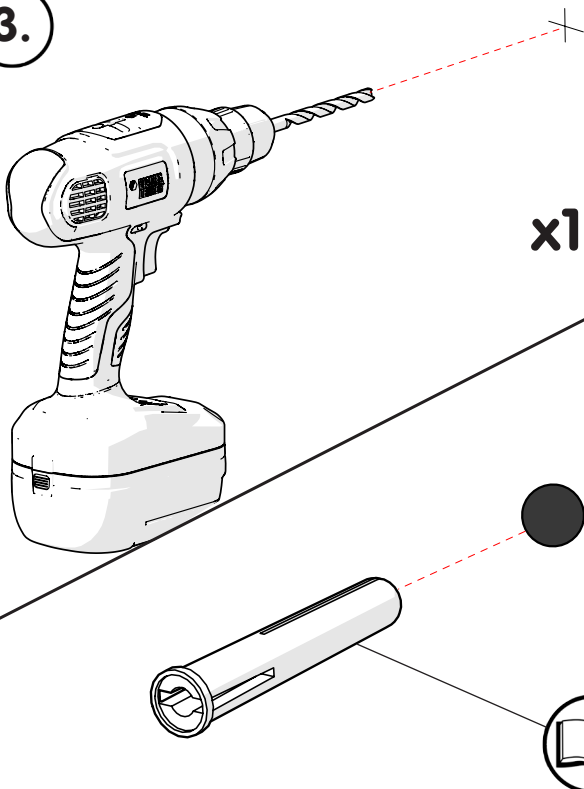

4.

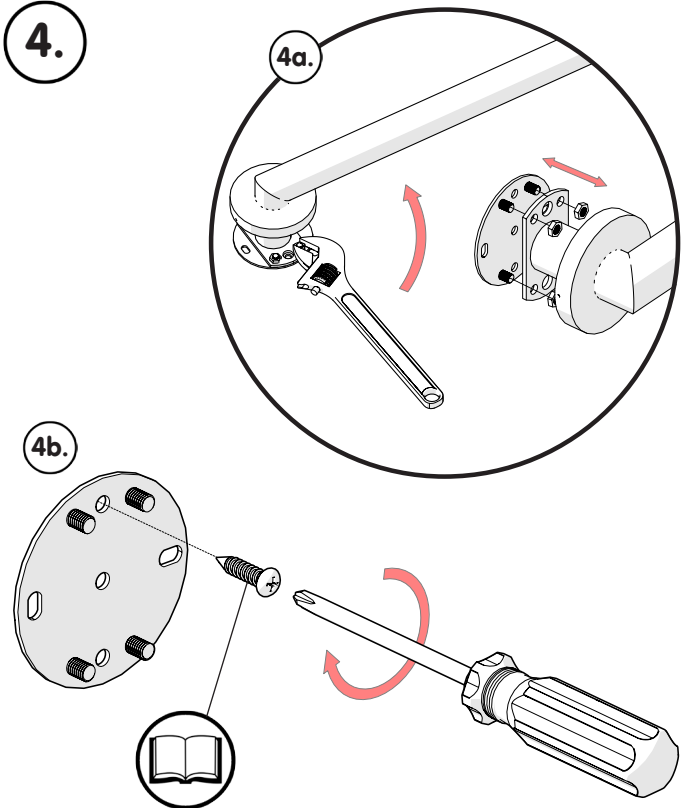

5.

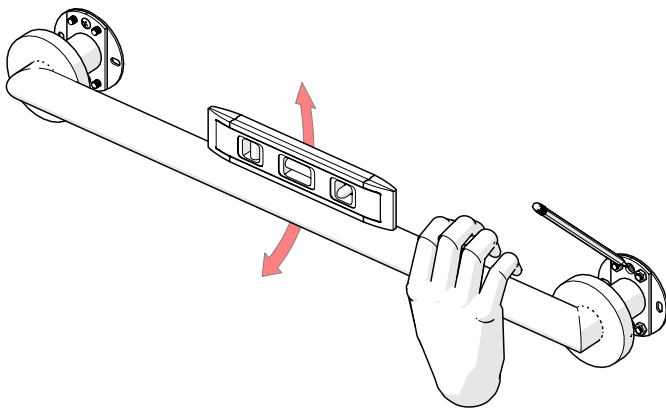

EN. Check level
 FR. Vérifier le niveau
 DE. Prüfniveau
 ES. Comprobar la nivelación
 IT. Verificate il livello
 PL. Sprawdz poziom



6.

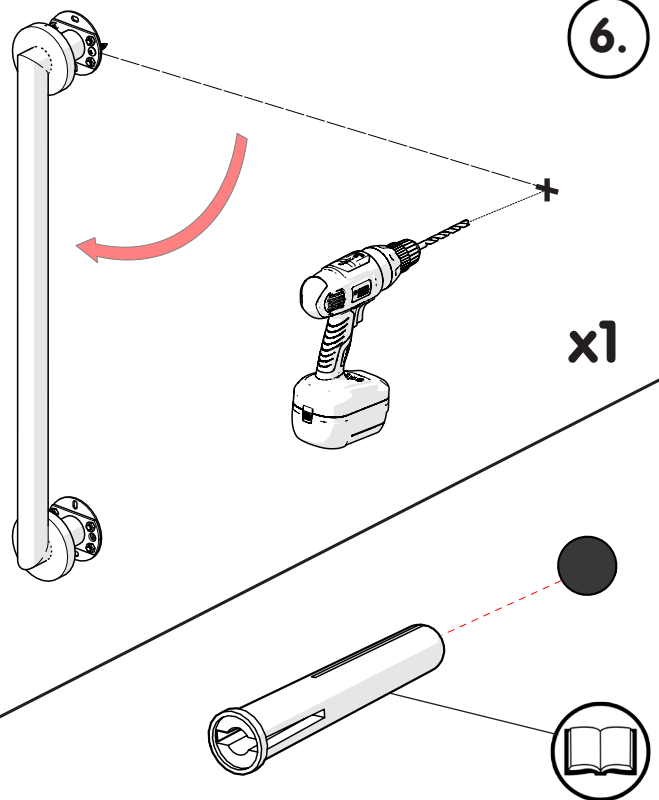

6.

Croydex, Central Way, Andover,
Hampshire, SP10 5AW, UK
 +44 (0) 1264 365881

+44 (0) 1264 356437
 info@croydex.co.uk

www.croydex.com

S&H 066 R01

7.

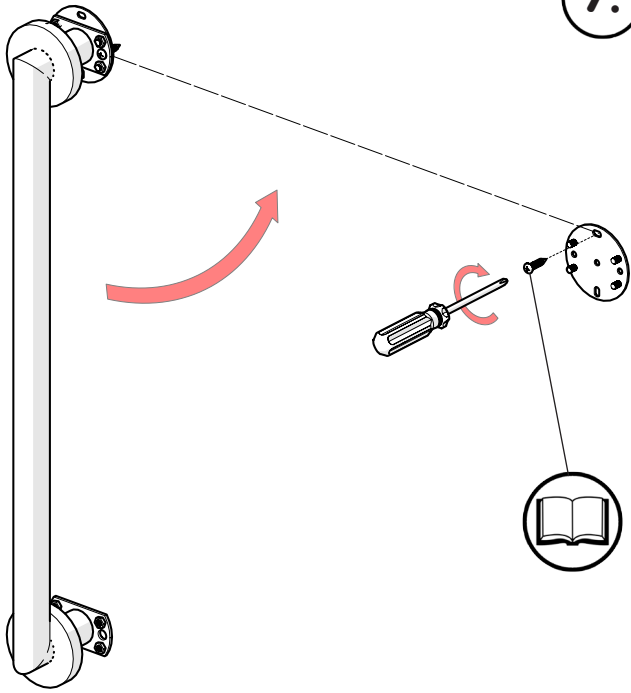

8.

EN. Check level
 FR. Vérifier le niveau
 DE. Prüfniveau
 ES. Comprobar la nivelación
 IT. Verificate il livello
 PL. Sprawdź poziom

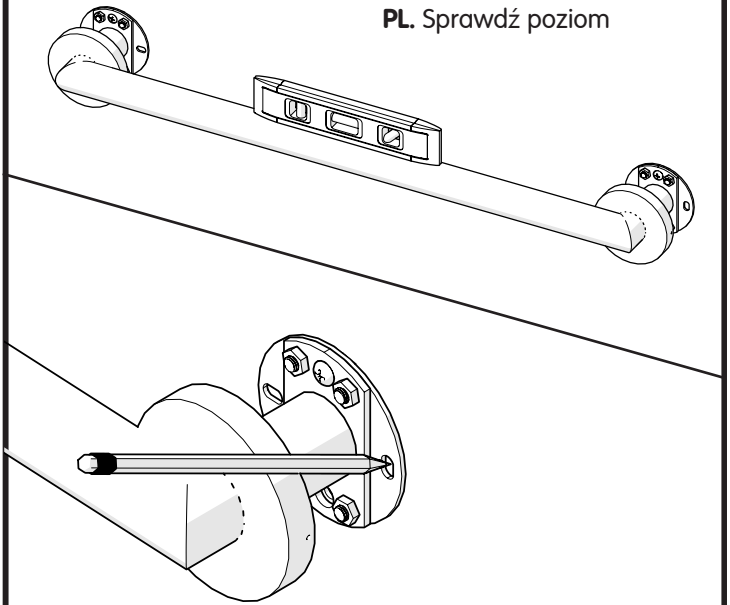

9.

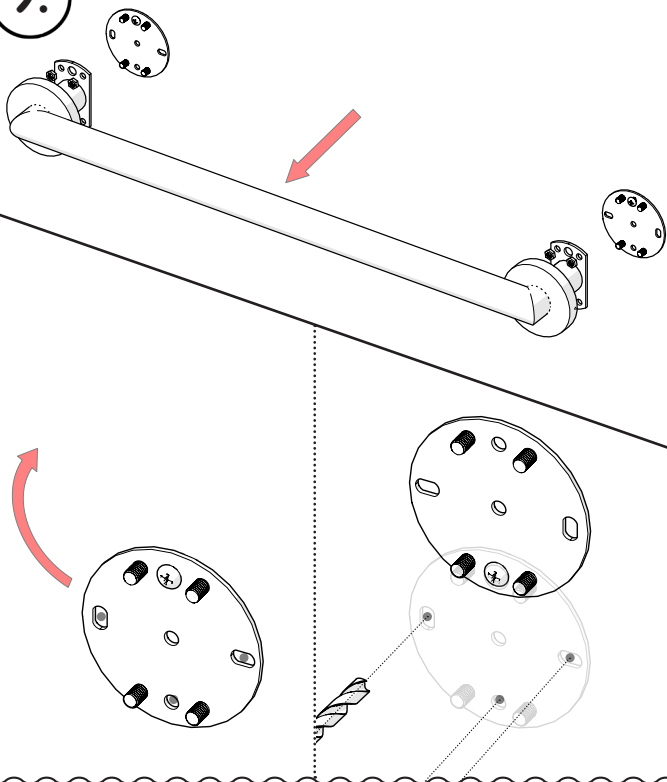

10.

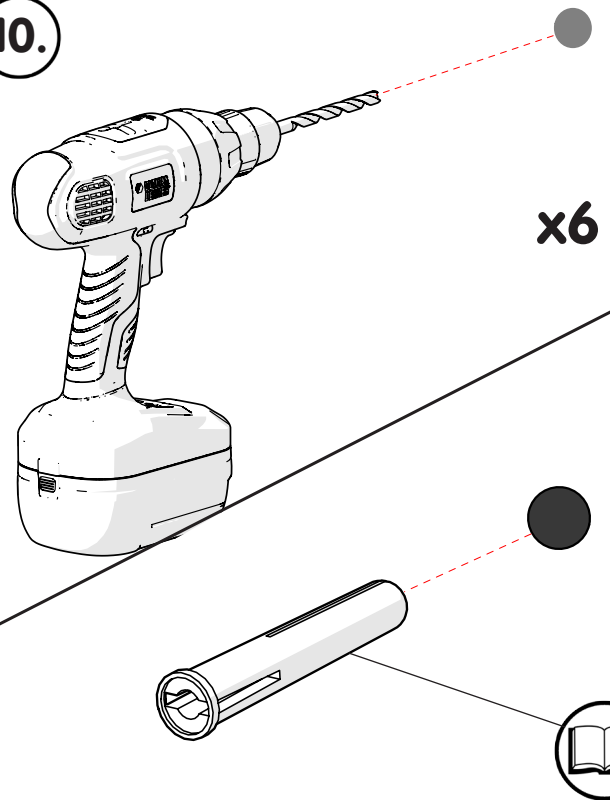

7.

Croydex, Central Way, Andover,
 Hampshire, SP10 5AW, UK

+44 (0) 1264 356437

www.croydex.com

+44 (0) 1264 365881

info@croydex.co.uk

S&H 066 R01

11.

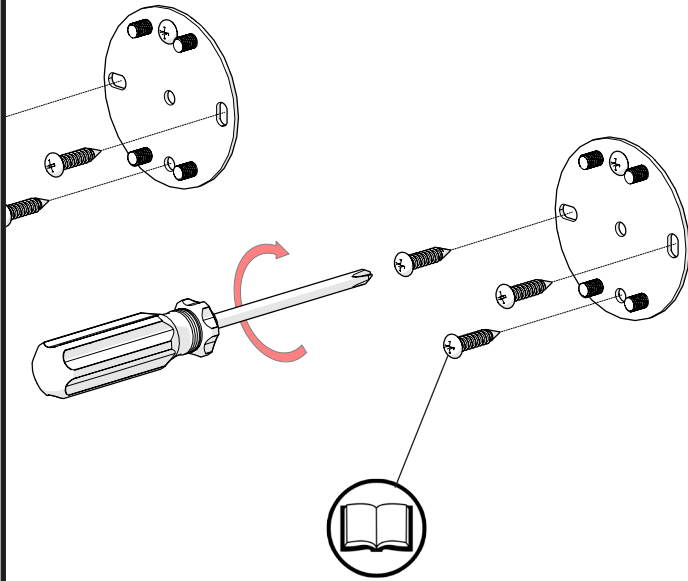

12.

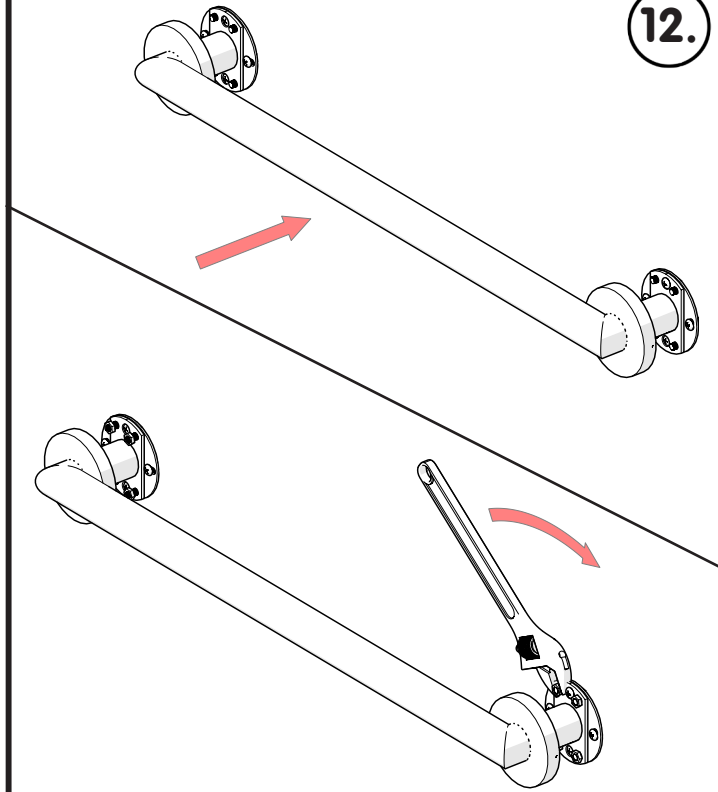

13.

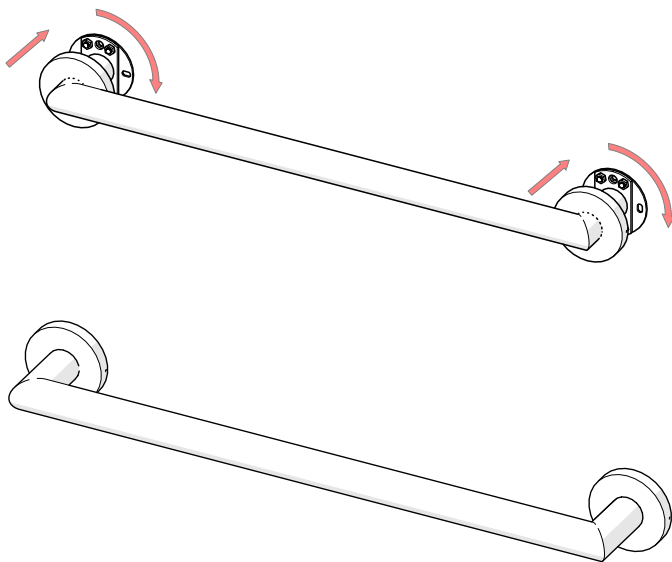

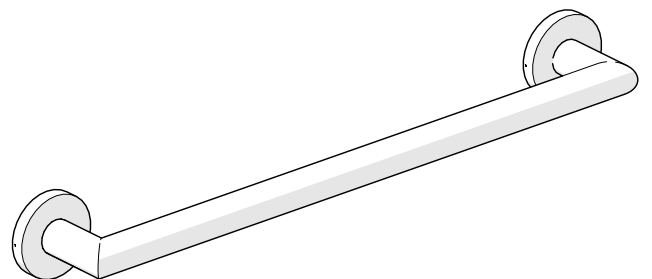

14.





EN. Test before use.
 FR. Faites un essai avant utilisation.
 DE. Vor der Verwendung testen.
 ES. Probar antes de usar.
 IT. Testate prima dell'uso.
 PL. Sprawdzić przed użyciem.



8.

 Croydex, Central Way, Andover,
Hampshire, SP10 5AW, UK
 +44 (0) 1264 365881

 +44 (0) 1264 356437
 info@croydex.co.uk

 www.croydex.com

S&H 066 R01