

01COMGRN0406-V1 - 4x6 Greenhouse Shed

8x6 Greenhouse with shed.
10x6 Greenhouse with shed.
12x6 Greenhouse with shed.

BEFORE YOU START PLEASE READ INSTRUCTIONS CAREFULLY

- Check the pack and make sure you have all the parts listed.
- When you are ready to start, make sure you have the right tools at hand (not supplied) including a Phillips screwdriver, Stanley knife, Wood saw, Step ladder, Hammer and a Drill with 2mm bit.
- Ensure there is plenty of space and a clean dry area for assembly.

TIMBER

As with all natural materials, timber can be affected during various weather conditions. For the duration of heavy or extended periods of rain, swelling of the wood panels may occur. Warping of the wood may also occur during excessive dry spells due to an interior moisture loss. Unfortunately, these processes cannot be avoided but can be helped. It is suggested that the outdoor building is sprayed with water during extended periods of warm sunshine and sheltered as much as possible during rain or snow.

Our buildings are pre treated with a water based treatment**; this only helps to protect the product during transit and for upto 3 months against mould. To validate your guarantee and ensure longevity of the product, it is ESSENTIAL the building is treated with a wood preserver within the first three months of assembly and thereafter in accordance with the manufactures recommendations. Care must be taken to ensure the product is placed on a suitable base.

BUILDING A BASE

When thinking about where the building and base is going to be constructed: Ensure that there will be access to all sides for maintenance work and annual treatment.

Ensure the base is level and is built on firm ground, to prevent distortion. Refer to diagrams for the base dimensions, The base should be slightly smaller than the external measurement of the building, i.e. The cladding should overlap the base, creating a run off for water. It is also recommended that the floor be at least 25mm above the surrounding ground level to avoid flooding.

TYPES OF BASE

- Concrete 75mm laid on top of 75mm hard-core.
- Slabs laid on 50mm of sharp sand.

Whilst all products manufactured are made to the highest standards of Safety and in the case of childrens products independently tested to EN71 level, we cannot accept responsibility for your safety whilst erecting or using this product.

Refer to the instructions pages for you specific product code



x2

All building's should be erected by two adults



Winter = High Moisture = Expansion
Summer = Low Moisture = Contraction



2mm Drill bit

For ease of assembly, you **MUST** pilot drill all screw holes and ensure all screw heads are countersunk.



CAUTION

Every effort has been made during the manufacturing process to eliminate the prospect of splinters on rough surfaces of the timber. You are strongly advised to wear gloves when working with or handling rough sawn timber.



For ease of assembly, you will need a tape measure to check dimensions of components.

Protim Aquatan T5 (621)

Your building has been treated with **Aquatan**.

Aquatan is a water-based concentrate which is diluted with water, the building as been treated by the correct application of Aquatan solution and then allowed to dry.

Aquatan is a decorative finish to colour the wood, which is applied industrially to timber fence panels and garden buildings.

Aquatan undiluted contains: boric acid, sodium hydroxide 32% solution, aqueous mixture of sodium dioctyl sulphosuccinat and alcohols: 2, 4, 6-trichlorophenol.

For assistance please contact customer care on: 01636 880514

**Mercia Garden Products Limited,
Sutton On Trent,
Newark,
Nottinghamshire,
NG23 6QN**

www.merciagardenproducts.co.uk

01COMGRN0406-V1: Plus 8x6, 10x6 & 12x6 Greenhouse with shed.

Please retain product label and instructions for future reference

4x6 Shed
Overall Dimensions:
 Width = 1972mm
 Depth = 1299mm
 Height = 2039mm

Base Dimensions:
 Width: 1860mm
 Depth: 1190mm

10x6 Greenhouse with shed
Overall Dimensions:
 Width = 1972mm
 Depth = 3030mm
 Height = 2039mm

Base Dimensions:
 Width: 1860mm
 Depth: 2980mm

8x6 Greenhouse with shed
Overall Dimensions:
 Width = 1972mm
 Depth = 2447mm
 Height = 2039mm

Base Dimensions:
 Width: 1860mm
 Depth: 2397mm

12x6 Greenhouse with shed
Overall Dimensions:
 Width = 1972mm
 Depth = 3615mm
 Height = 2039mm

Base Dimensions:
 Width: 1860mm
 Depth: 3560mm

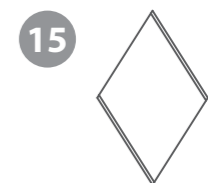
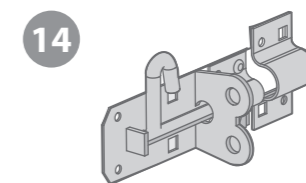
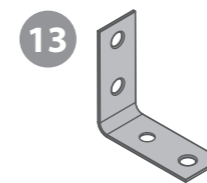
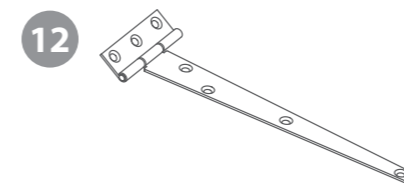
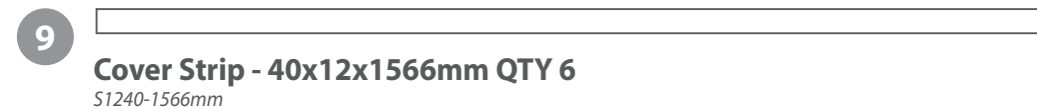
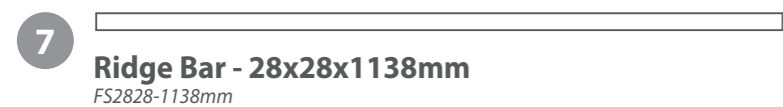
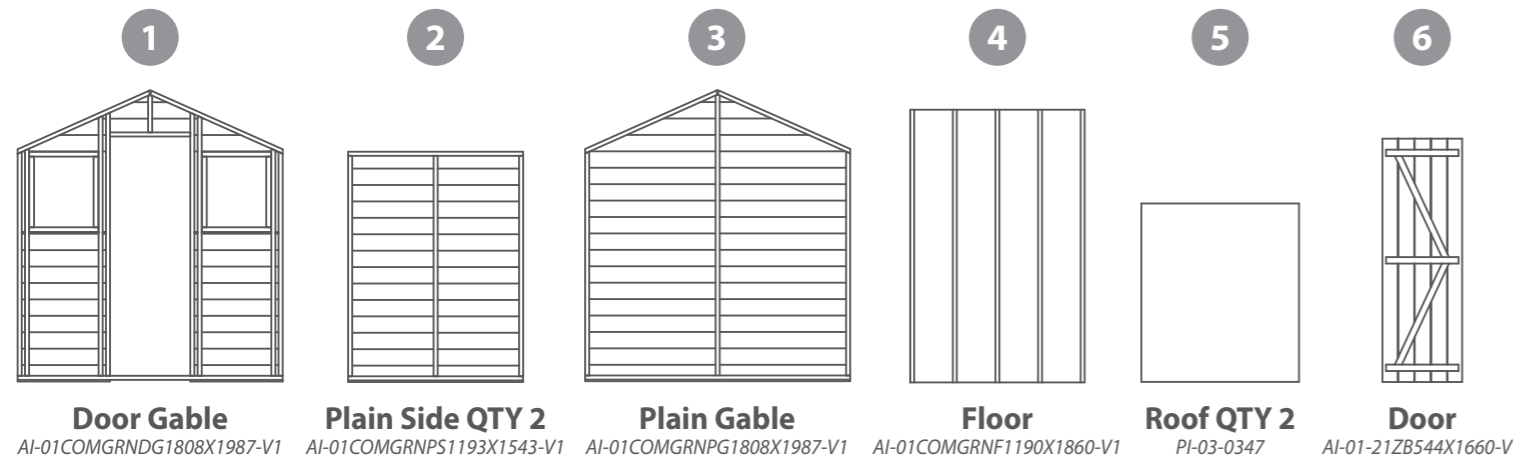
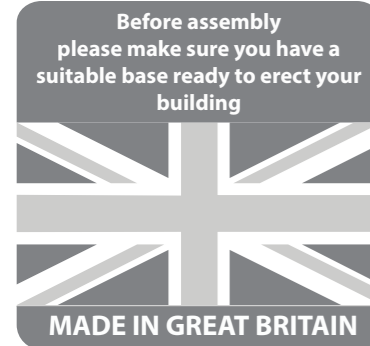
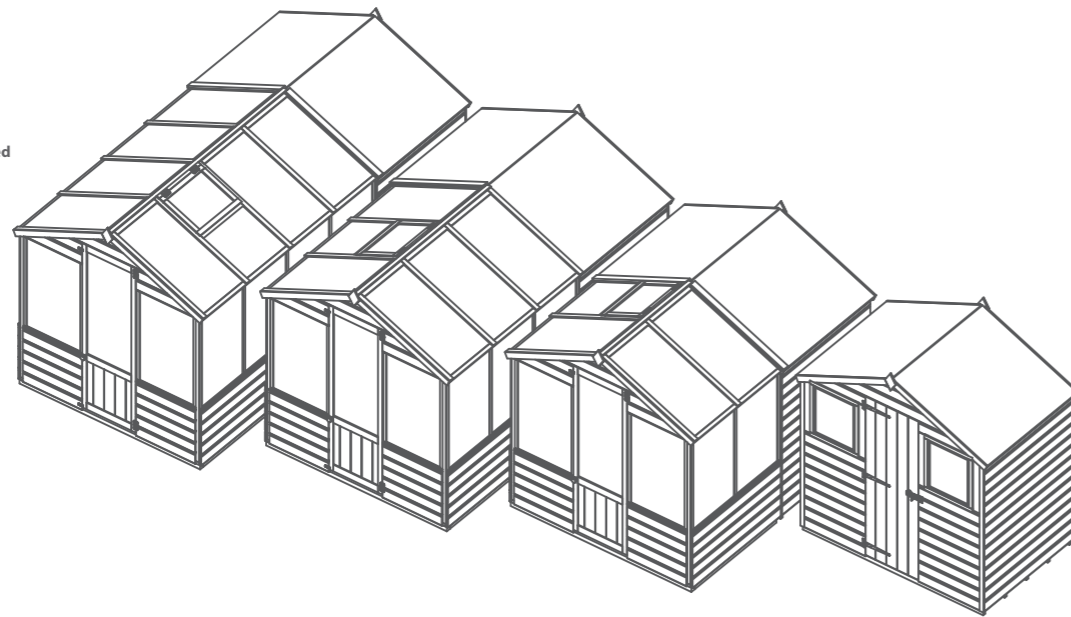

****For greenhouse contents please see instructions before beginning assembly.****

Nail Bag

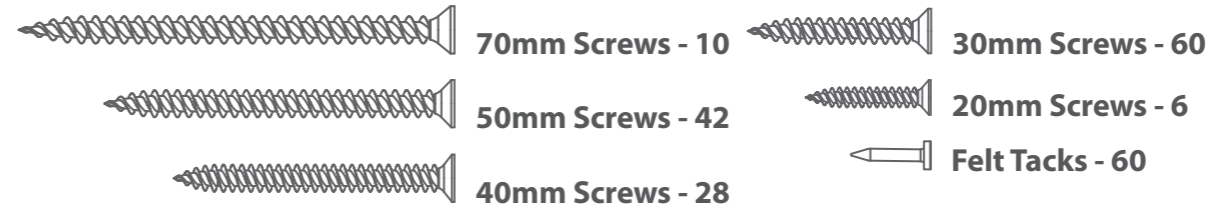

Pre Assembly

Before beginning assembly remove the transport blocks from the bottom of each panel.

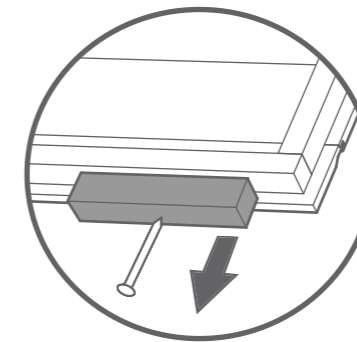

Step 1

Place the door (**No. 6**) into the door gable (**No. 1**) aperture, making sure there is an equal amount of space either side of the door.

Once in place secure the door to the door gable using 3x T-hinges (**No. 12**) securing each hinge into position with 7x30mm screws.

21x30mm screws.

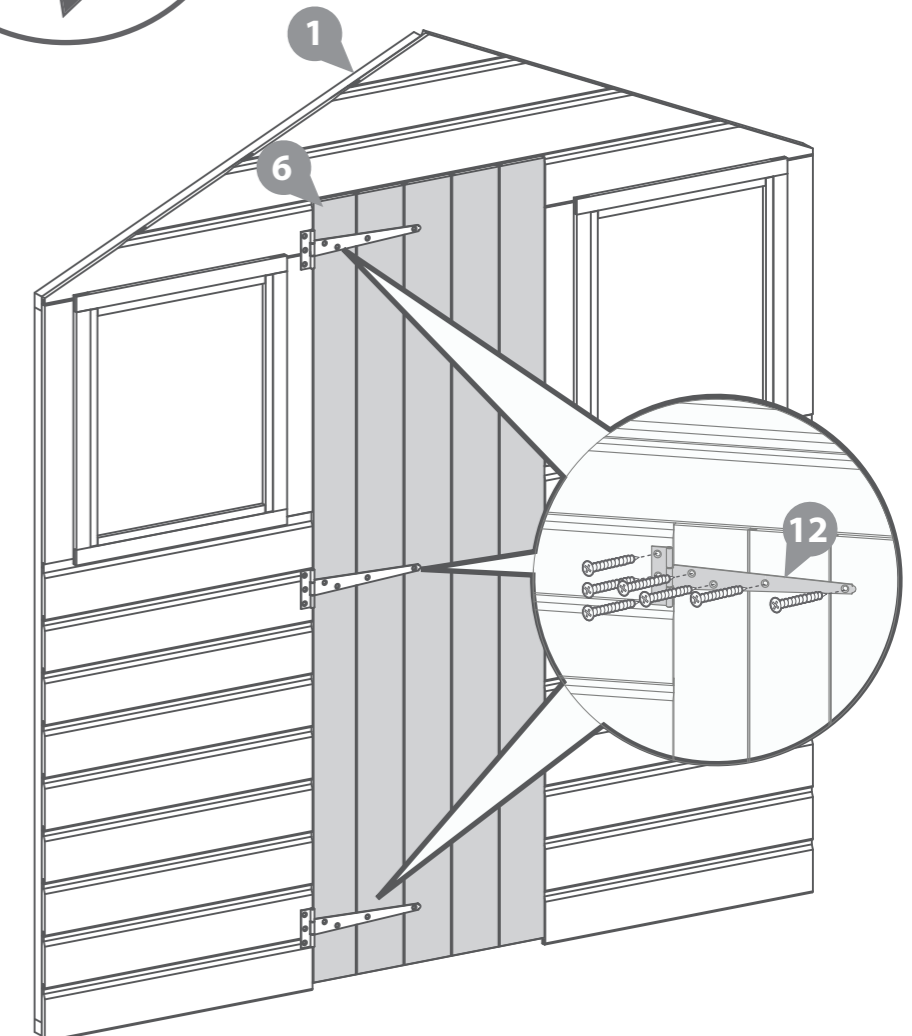

Step 2

Place the floor (**No. 4**) onto a firm and level surface.

Ensure your base has suitable drainage and is free from areas where standing water can collect.

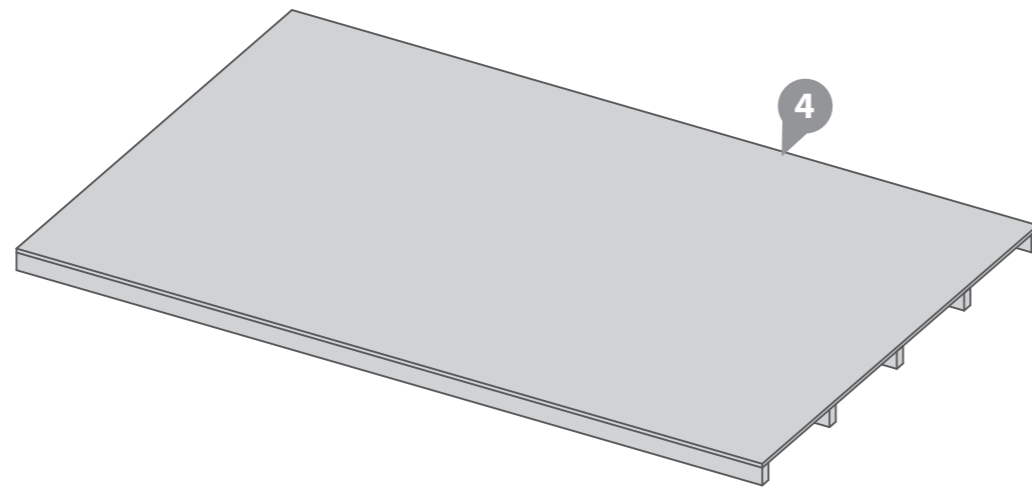

Step 3

a Place the plain gable (**No.3**) and one of the plain panels (**No.2**) on to the floor and fix the corners together using 3x50mm screws.

b Do not secure the building to the floor until the roof is secured in place.

**Ensure the plain gable is fitted on the inside of the plain panel. Screw through the plain gable framing into the framing of the plain panel.*

3x50mm screws

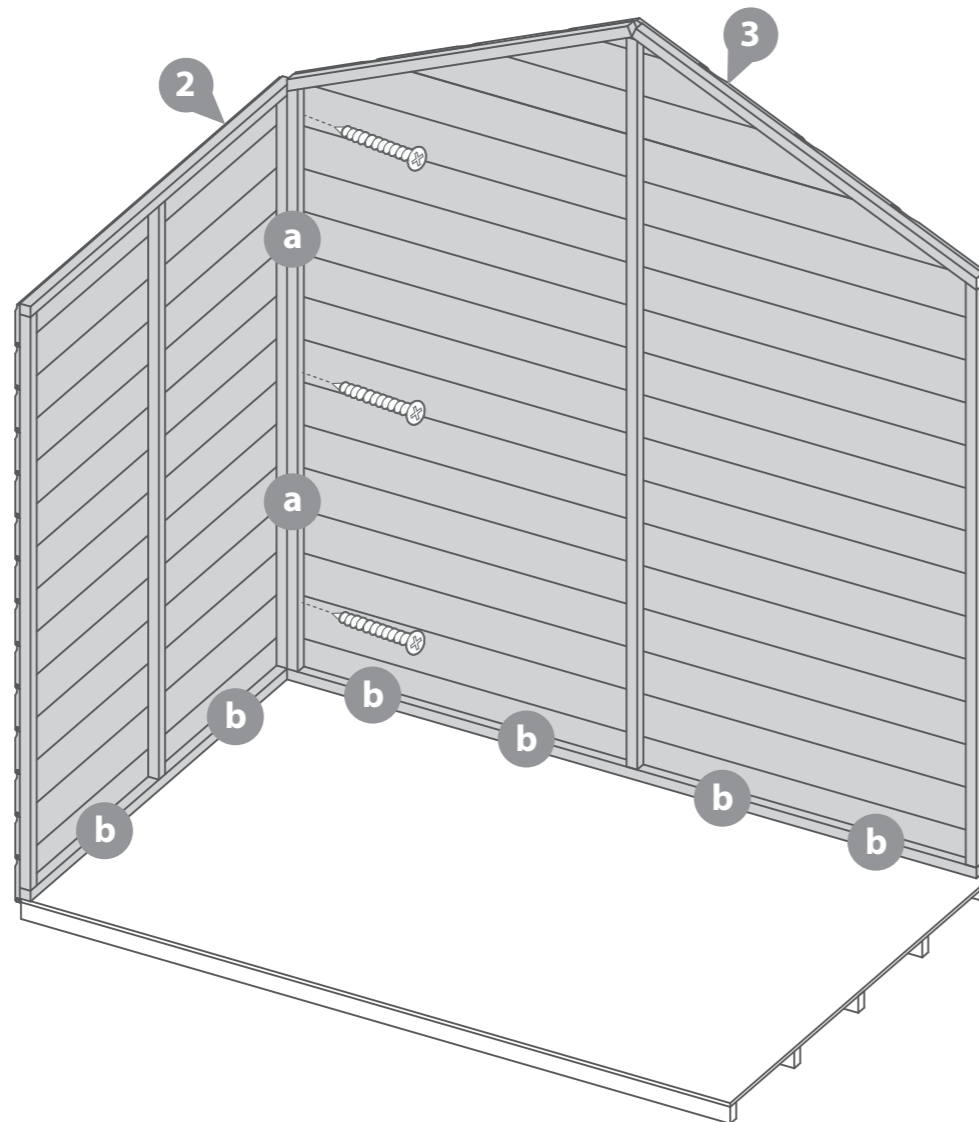

Step 4

a Following the same method outlined in **Step 3** place the second plain panel and assembled door gable onto the floor and fix at each corner using 50mm screws.

b Do not secure the building to the floor until the roof is secured in place.

9x50mm screws

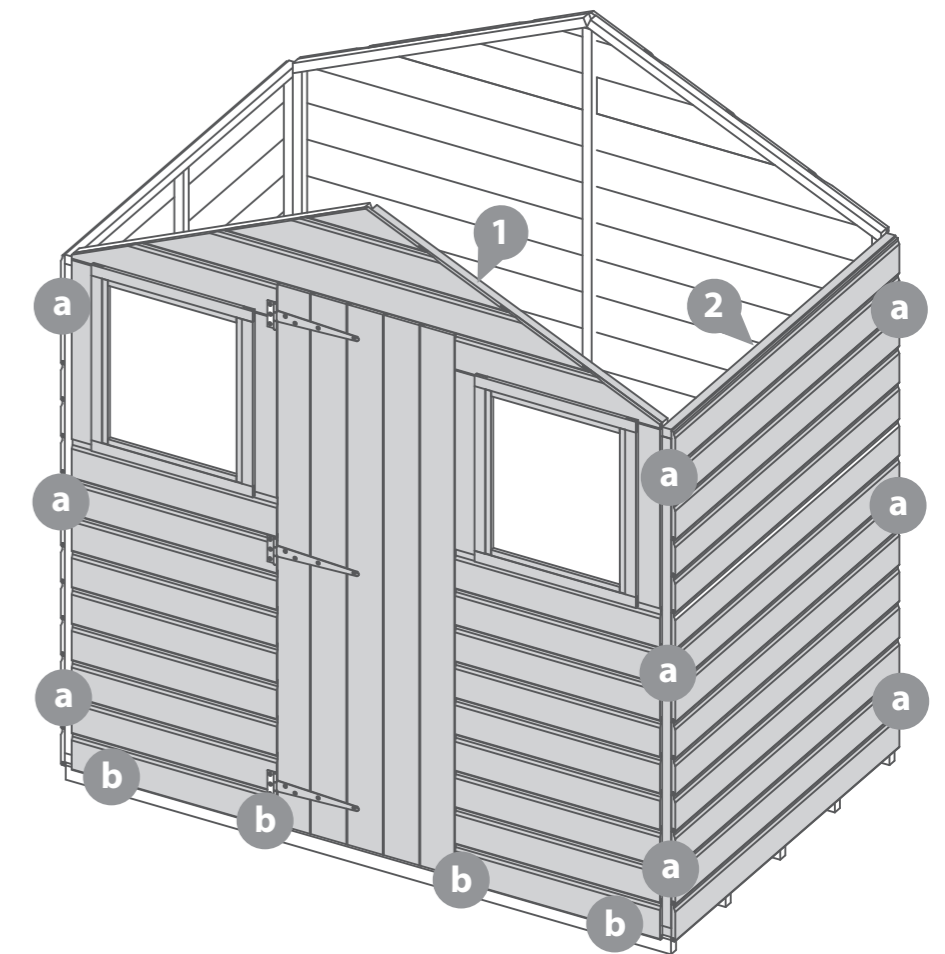
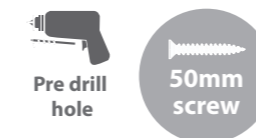

Step 5

Fix the 2x "L" brackets (**No. 13**) to either end of the ridge bar (**No. 7**) using 2x20mm screws per bracket.

**Ensure the bracket plate(s) are flush with each end of the ridge bar.*

Once in place position the ridge bar between the gables, securing into position using 2x30mm screws per side.

4x20mm Screws
4x30mm Screws

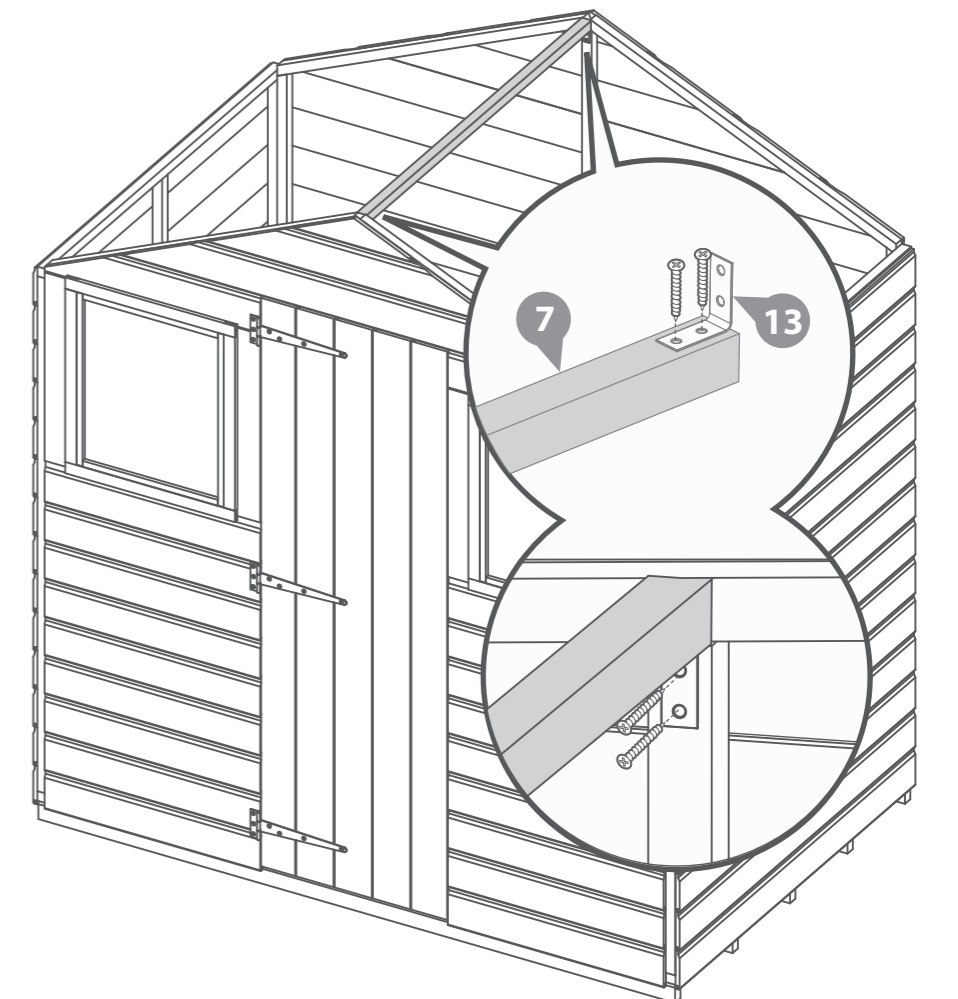

Step 6

Attach an eaves frame (**No. 8**) to one edge of each roof sheet (**No. 5**) using 4x30mm screws per roof.

Fix each roof onto the building with 16x30mm screws per roof, making sure the sheets meet at the apex.

40x30mm Screws

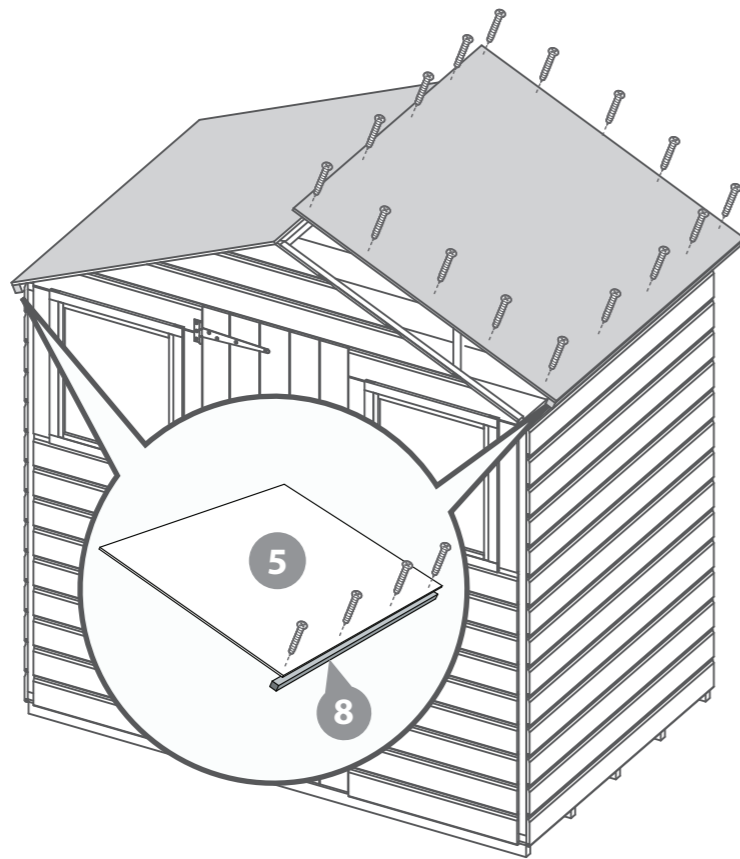
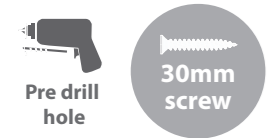

Step 8

Place a cover trim (**No. 9**) at each corner of the building & fix into position using 3x30mm screws per strip.

12x30mm Screws

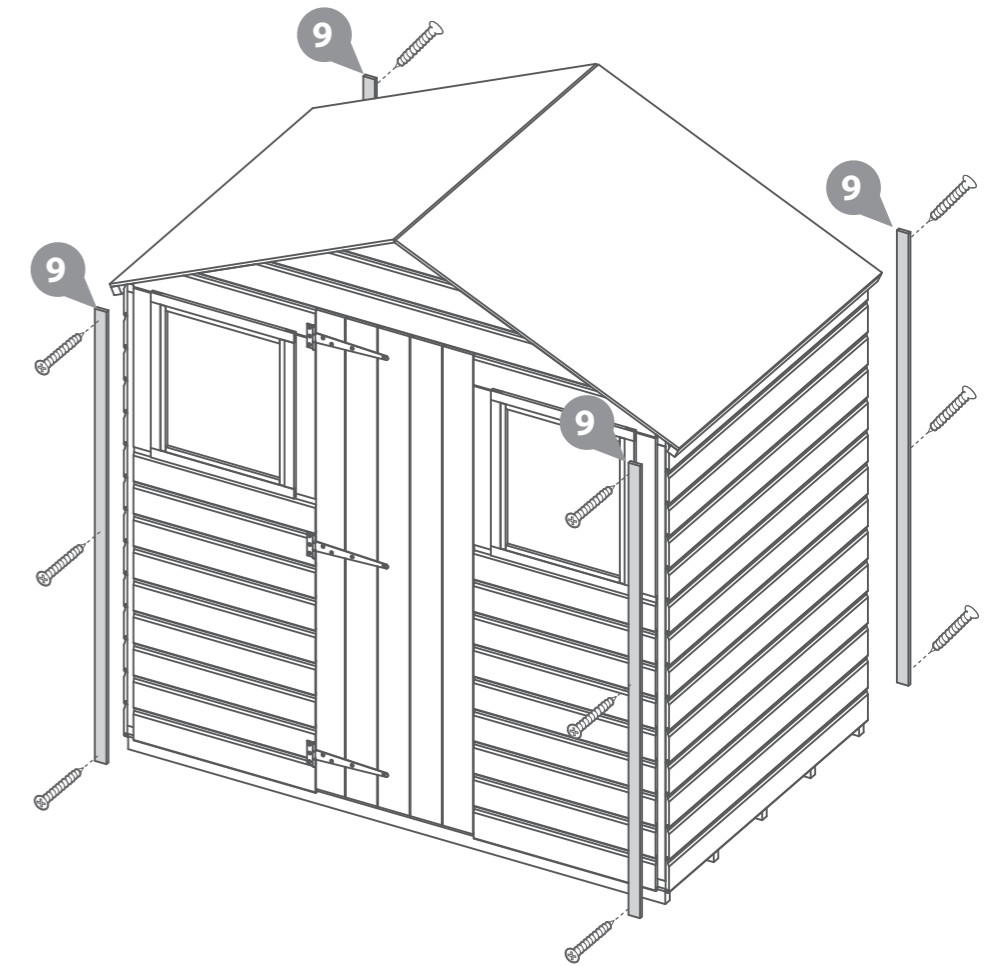
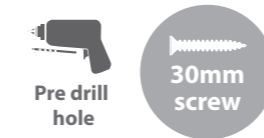

Step 7

b Once the roof has been fixed into place secure the building to the floor using 20x50mm screws.

**Ensure to screw through the panel framing into the floor bearers below.*

20x50mm screws

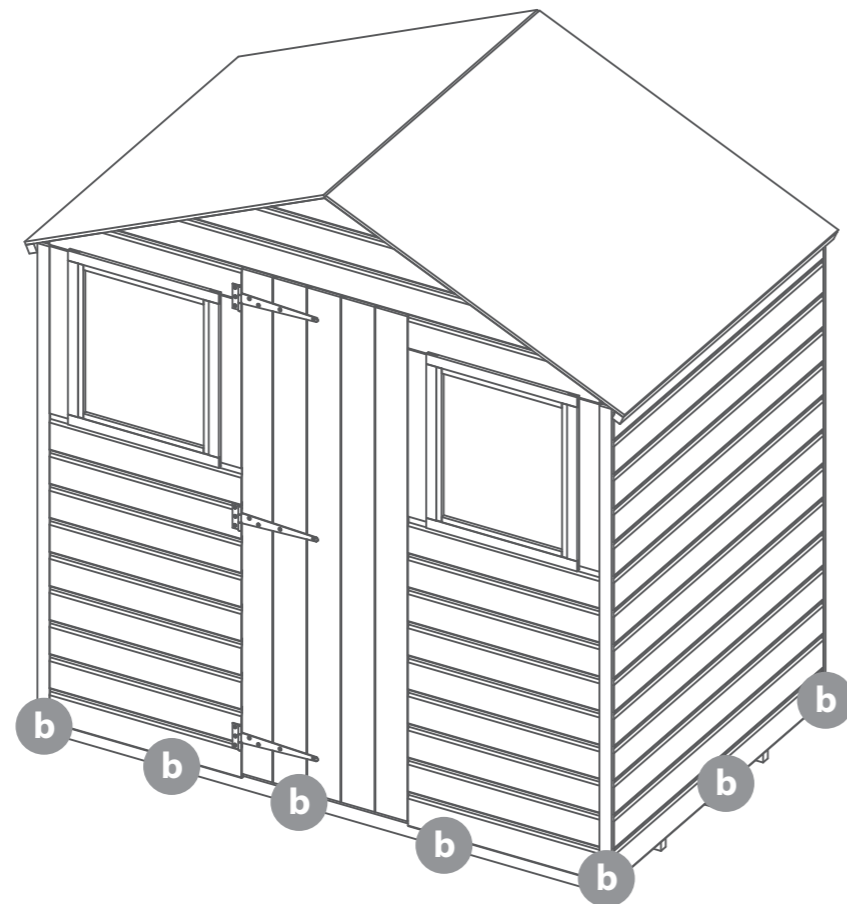
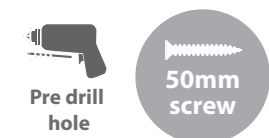

Step 9

Cut the felt into three strips and lay onto the as shown in the illustration.

***Ensure there is approximately 50mm of overhanging felt around the building.**

Fix the felt into place using felt tacks at 100mm intervals.

60x Felt Tacks



Felt Size: 1317mm

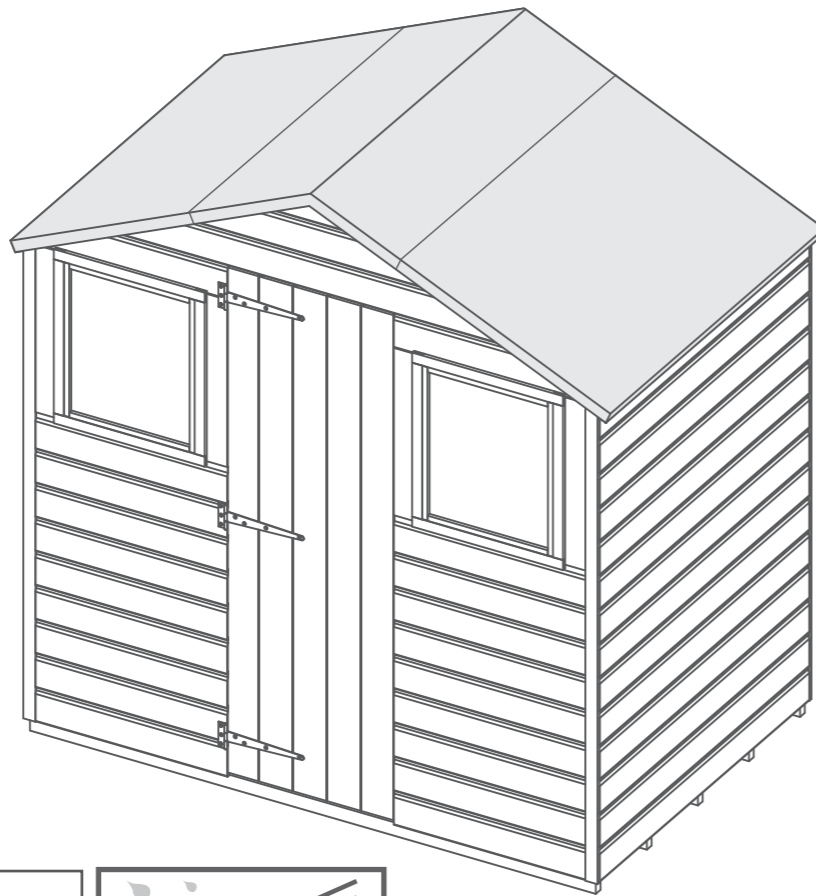

Step 10

****If attaching a greenhouse move onto Step 11.****

Secure the fascia's (**No. 10**) and the finial's (**No. 15**) to the front and rear of the building using 40mm screws.

***Ensure to trap the felt between the fascia(s) and the building.**

16x40mm Screws

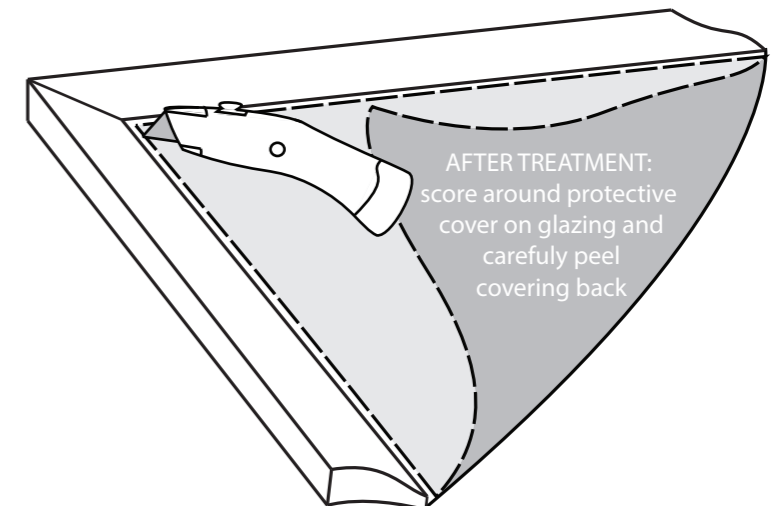
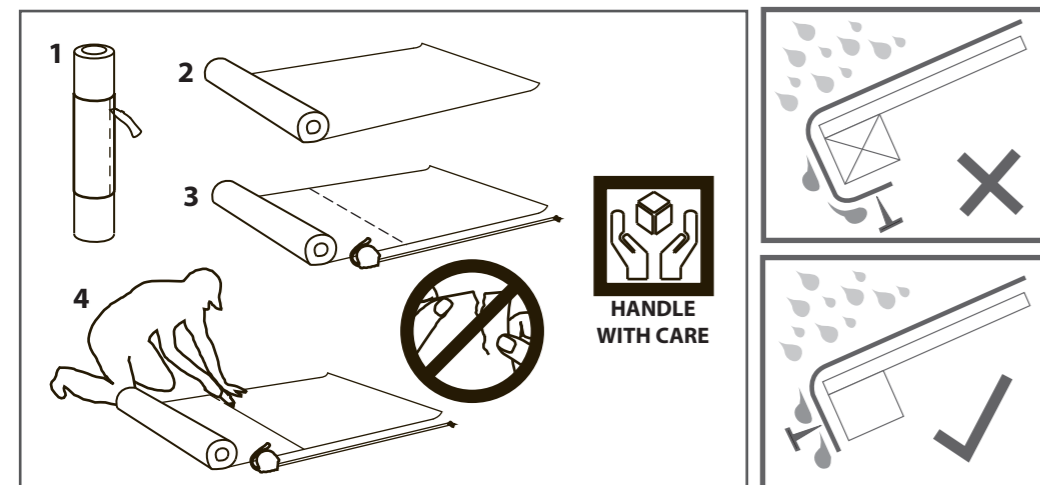
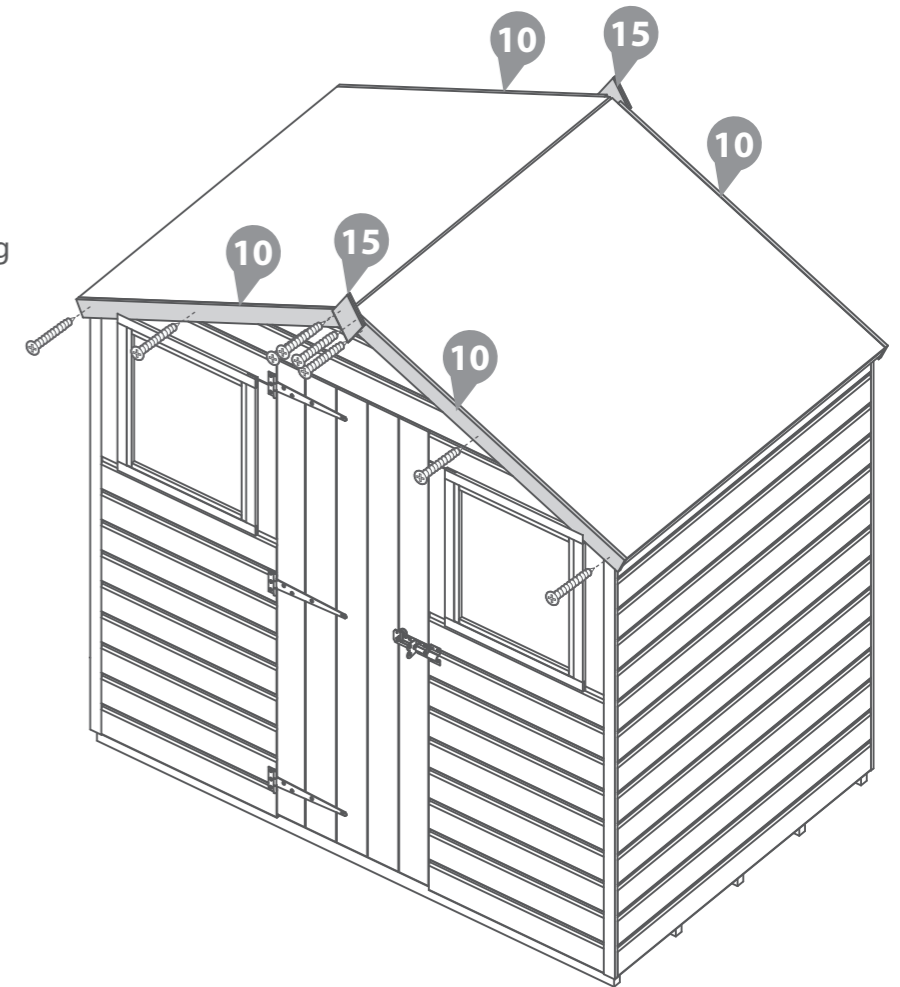

****Please note: For greenhouse contents please see instructions before beginning assembly. Not every panel from the greenhouse will be used****

****Please note: This product can be erected with the shed door either inside the building (internal) or outside (external). Before beginning assembling, decide which configuration best suits your needs and read through both sets of instructions carefully.****

Instructions: Internal shed door option.

Step 11 (internal)

Lay the base frame(s) onto the base as shown in the illustration.

***Ensure your framing is square and is placed against the front of the shed.**

Secure the base frames together at each corner using 8x70mm screws - **See greenhouse nail bag.**

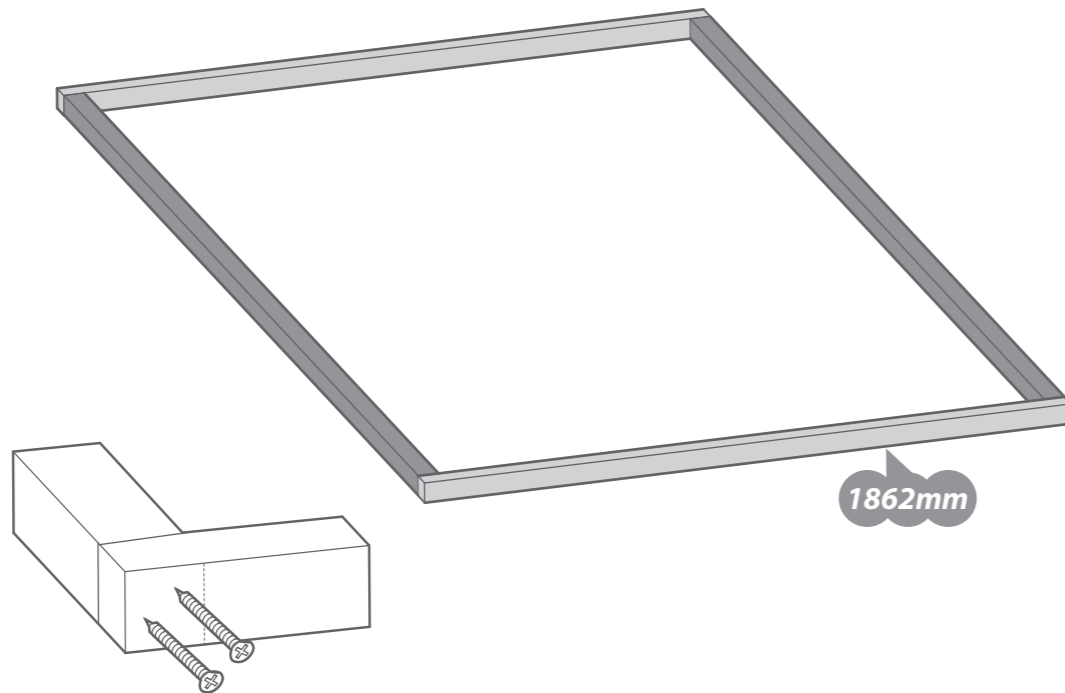

Step 12 (internal)

Place the two window panel(s) onto the base frame (**See Step 11**) against the shed and fix into position using 50mm screws. Ensure to screw through the panel(s) into the framing underneath - **See greenhouse nail bag.**

See greenhouse instructions for screw quantities.



Window panel sizes:

4x6 Greenhouse = 1193mm
(8x6 Greenhouse with shed)

6x6 Greenhouse = 1776mm
(10x6 Greenhouse with shed)

8x6 Greenhouse = 2359mm
(12x6 Greenhouse with shed)

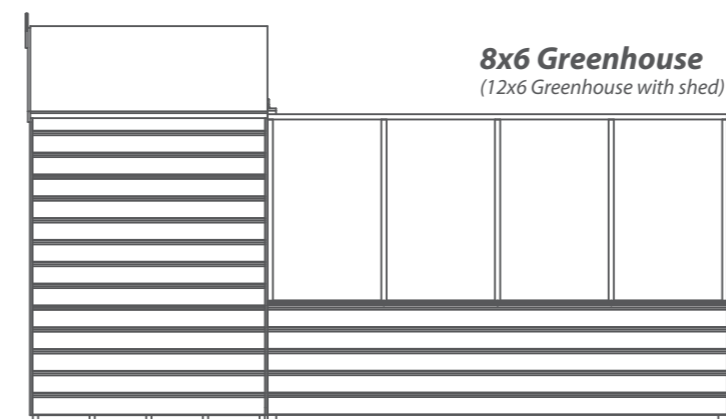
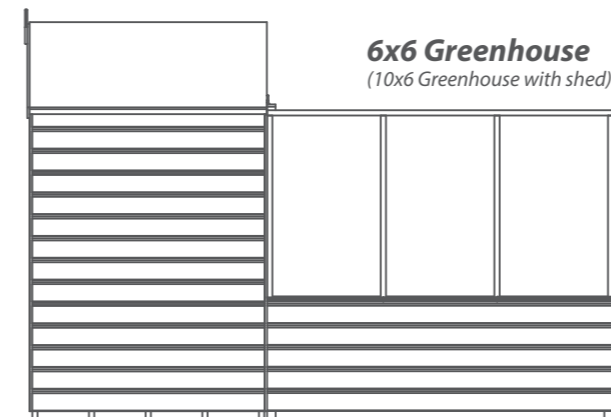
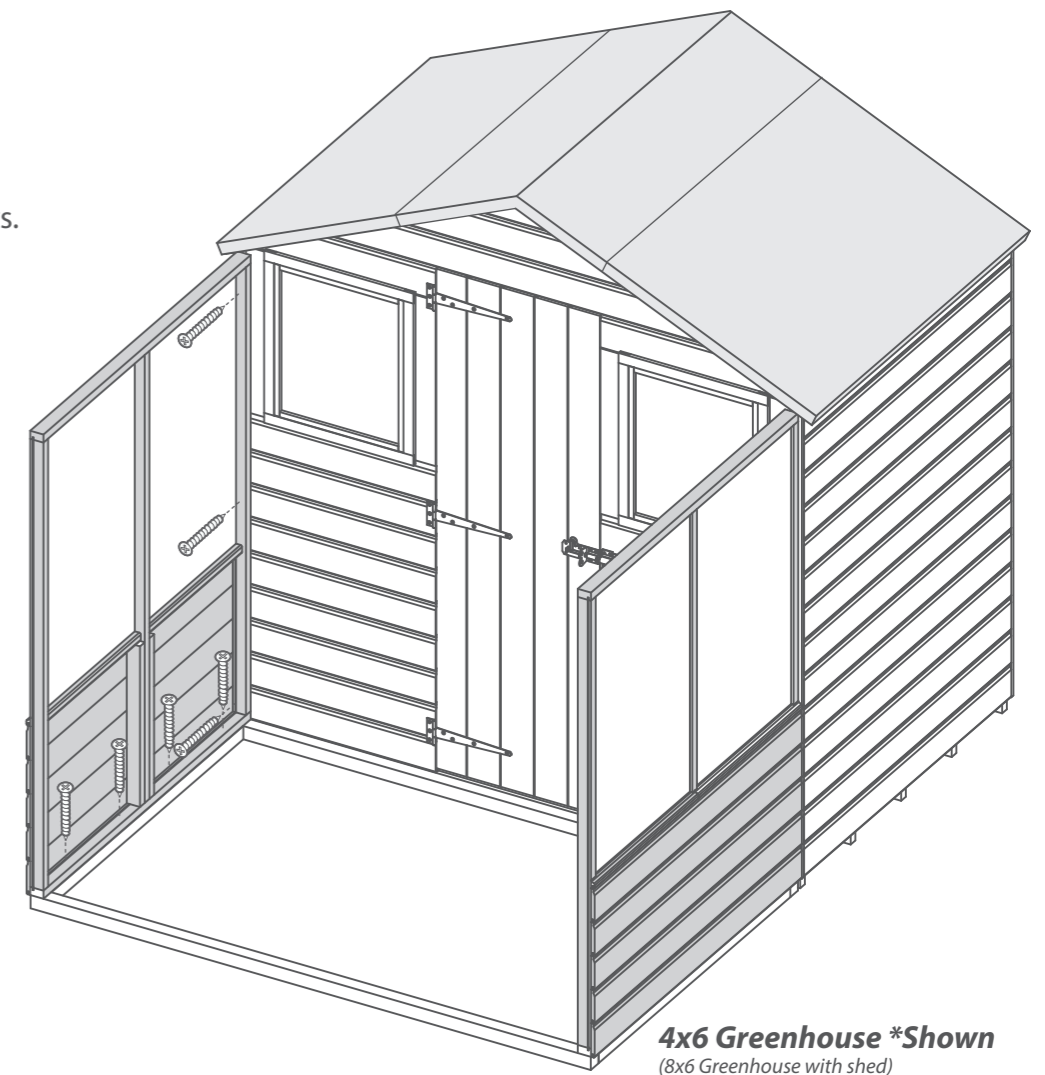

Step 13 (internal)

a Following the same method outlined in **Step 12**, rest the door side panels onto the assembly and secure into position using 50mm screws.

See greenhouse instructions for screw quantities.



Door side panel size = 610mm

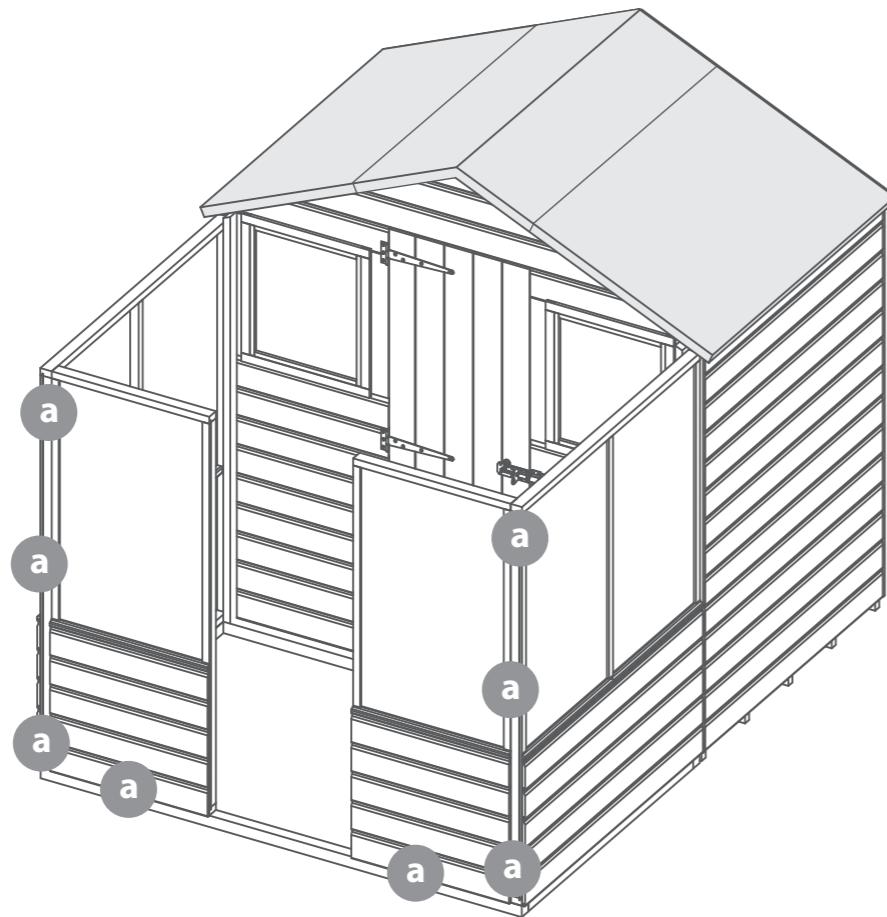

Step 14 (internal)

Attach the door gable top to the front of the building as shown in the illustration using 50mm screws - **See greenhouse nail bag.**

See greenhouse instructions for screw quantities.

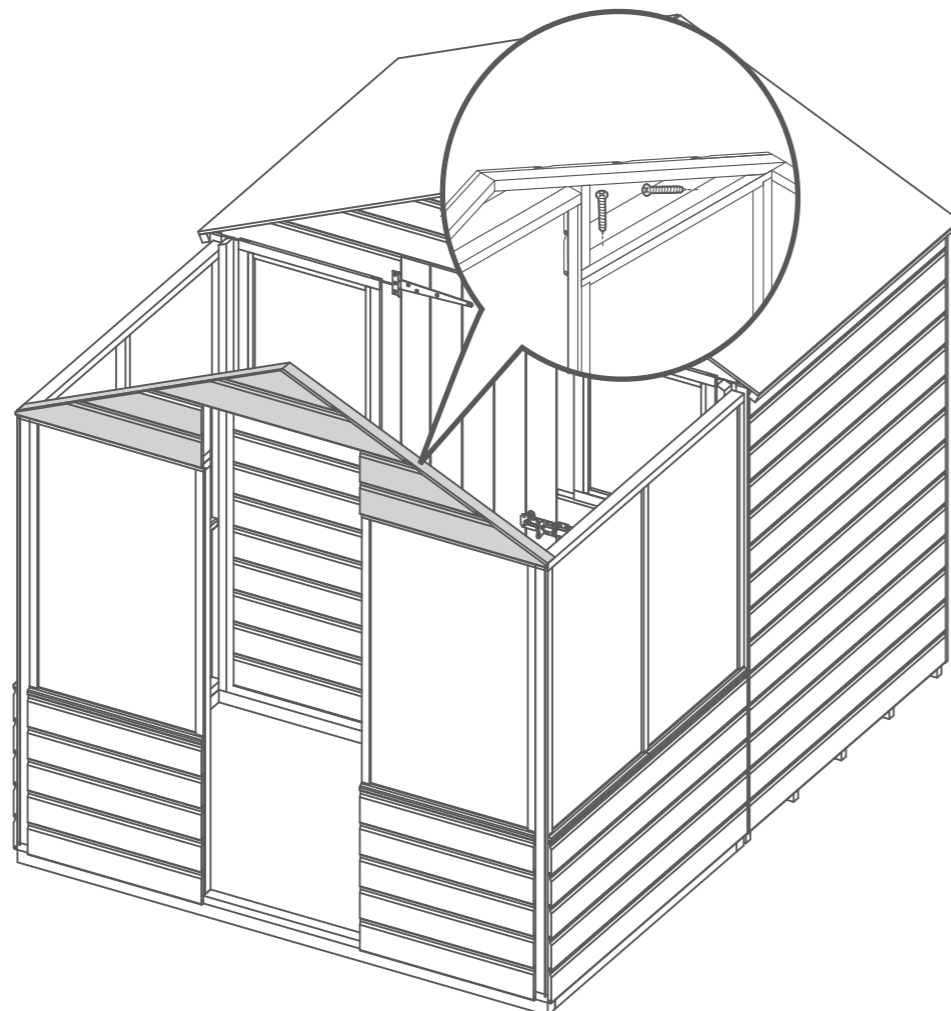

Step 15 (internal)

Place the window into the roof and secure into position using 6x16mm screws and 6x30mm screws as shown in the illustration - **See greenhouse nail bag.**

See greenhouse instructions for screw quantities.

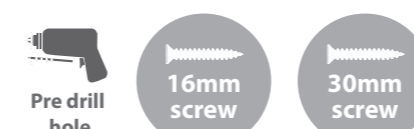

Roof sizes:

4x6 Greenhouse = 1217mm
(8x6 Greenhouse with shed)

6x6 Greenhouse = 1800mm
(10x6 Greenhouse with shed)

8x6 Greenhouse = 2385mm
(12x6 Greenhouse with shed)

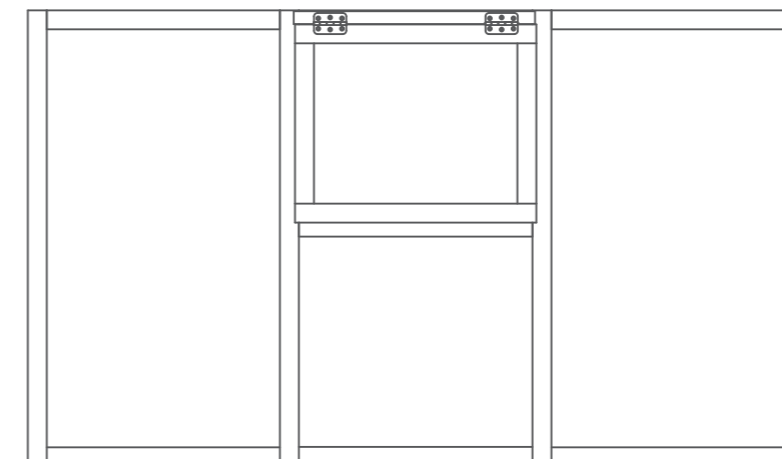
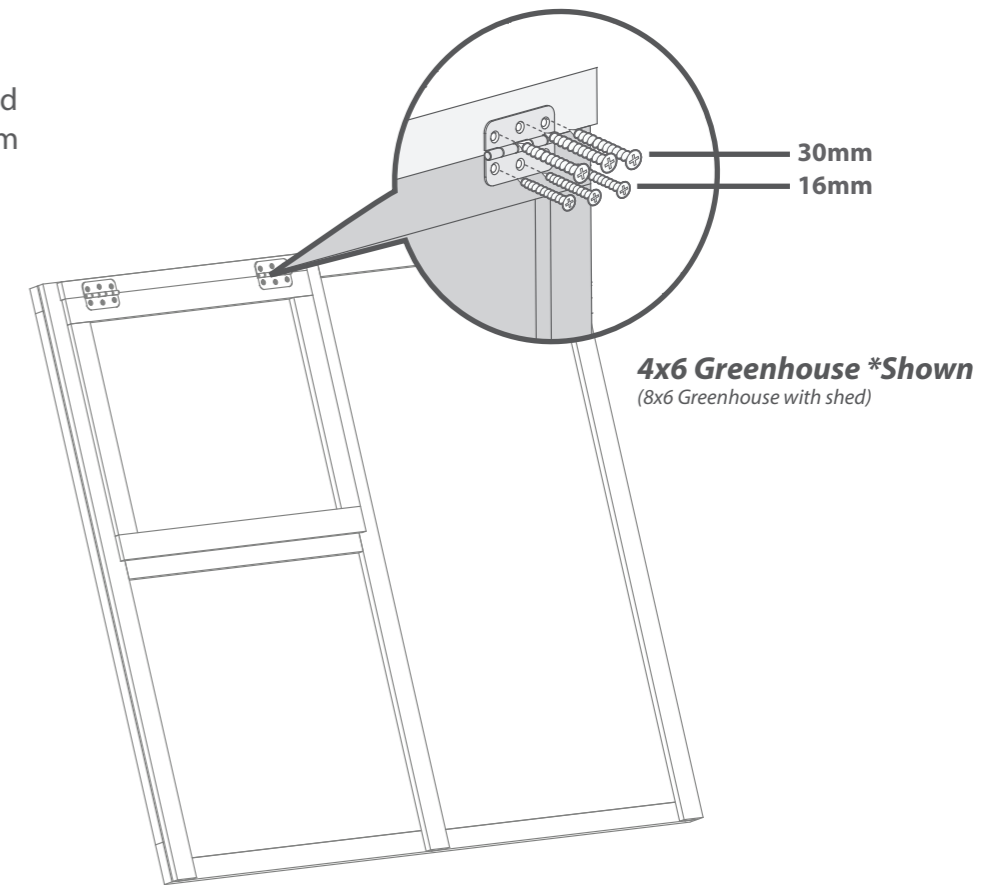

6x6 Greenhouse
(10x6 Greenhouse with shed)

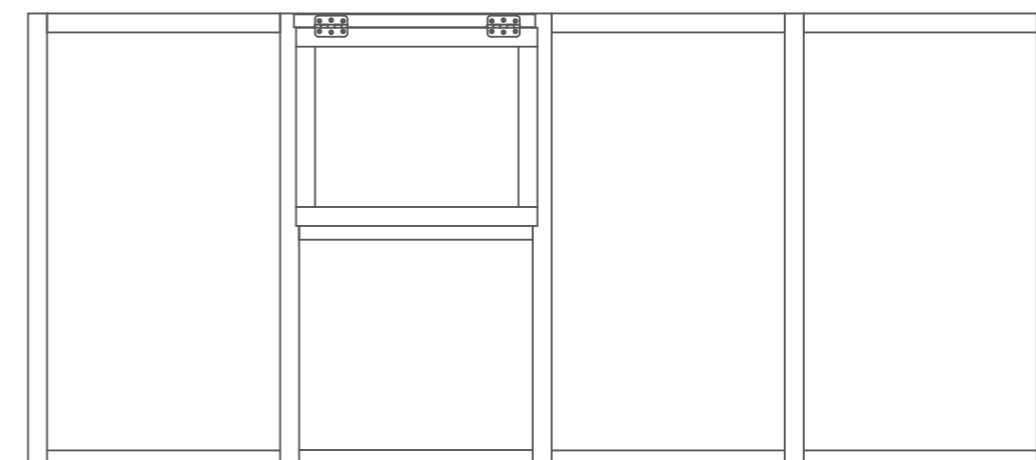

8x6 Greenhouse
(12x6 Greenhouse with shed)

Step 16 (internal)

Fix the casement stay to the window using 20mm screws as shown in the illustration. once in position secure the pins to the roof framing with 20mm screws, ensuring the stay and pins align and lock the window - **See greenhouse nail bag.**

See greenhouse instructions for screw quantities.

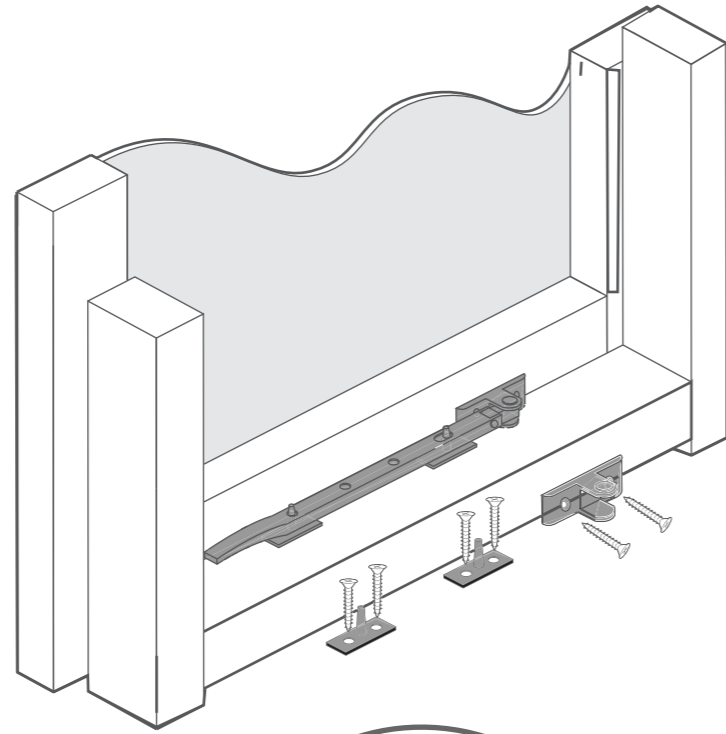

Step 18 (internal)

Using the roof's as a guide, mark the position for the roof block (**No. 12**) at the top of the **shed door gable**.

Once marked secure the block to the gable using 1x70mm screw, making sure to secure through the block into the central upright on the door gable.

1x70mm Screws

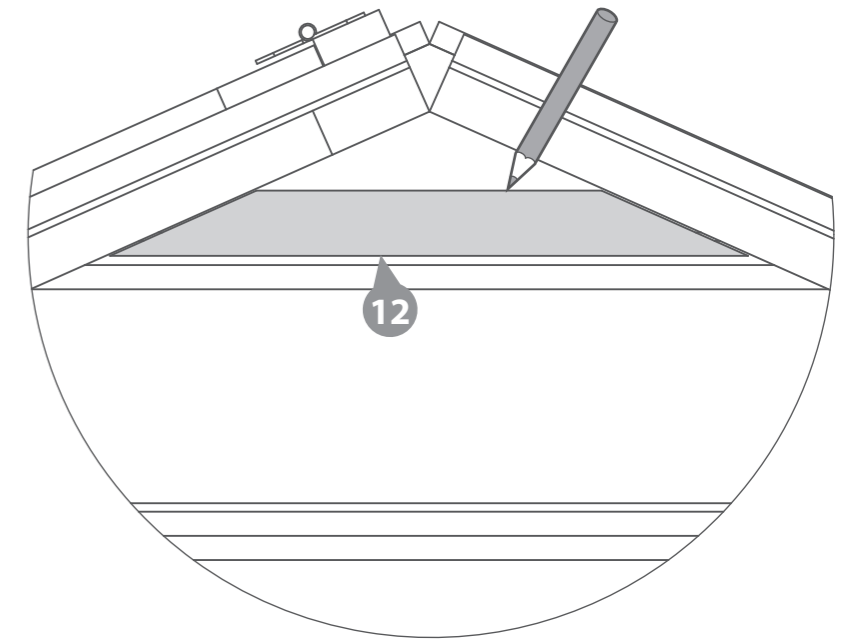

Step 17 (internal)

Place the greenhouse roof frame(s) (**No. 11** - See front page) against each window panel and secure in place using 3x50mm screws per frame, ensuring to screw into each panel.

6x50mm Screws

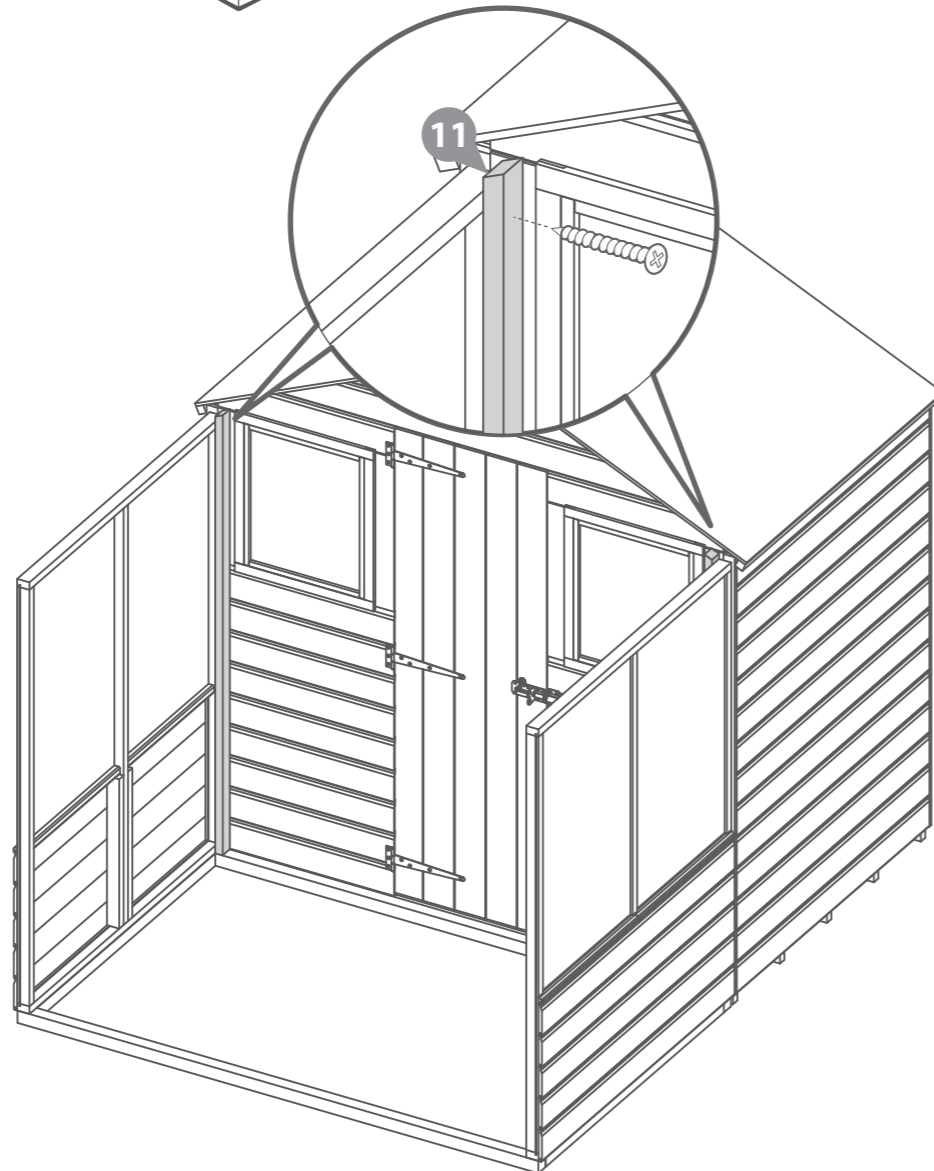
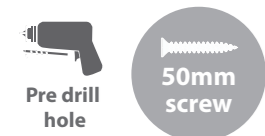

Step 19 (internal)

With the roof block in place, position the roof's onto the assembly ensuring they rest on top of the gable top and roof block (some adjustment may be necessary).

Once aligned secure the roofs into situ - **See greenhouse nail bag** Internally screw through the roof block into each roof panel as shown in the illustration using 2x50mm screws.

See greenhouse instructions for screw quantities.

2x50mm Screws

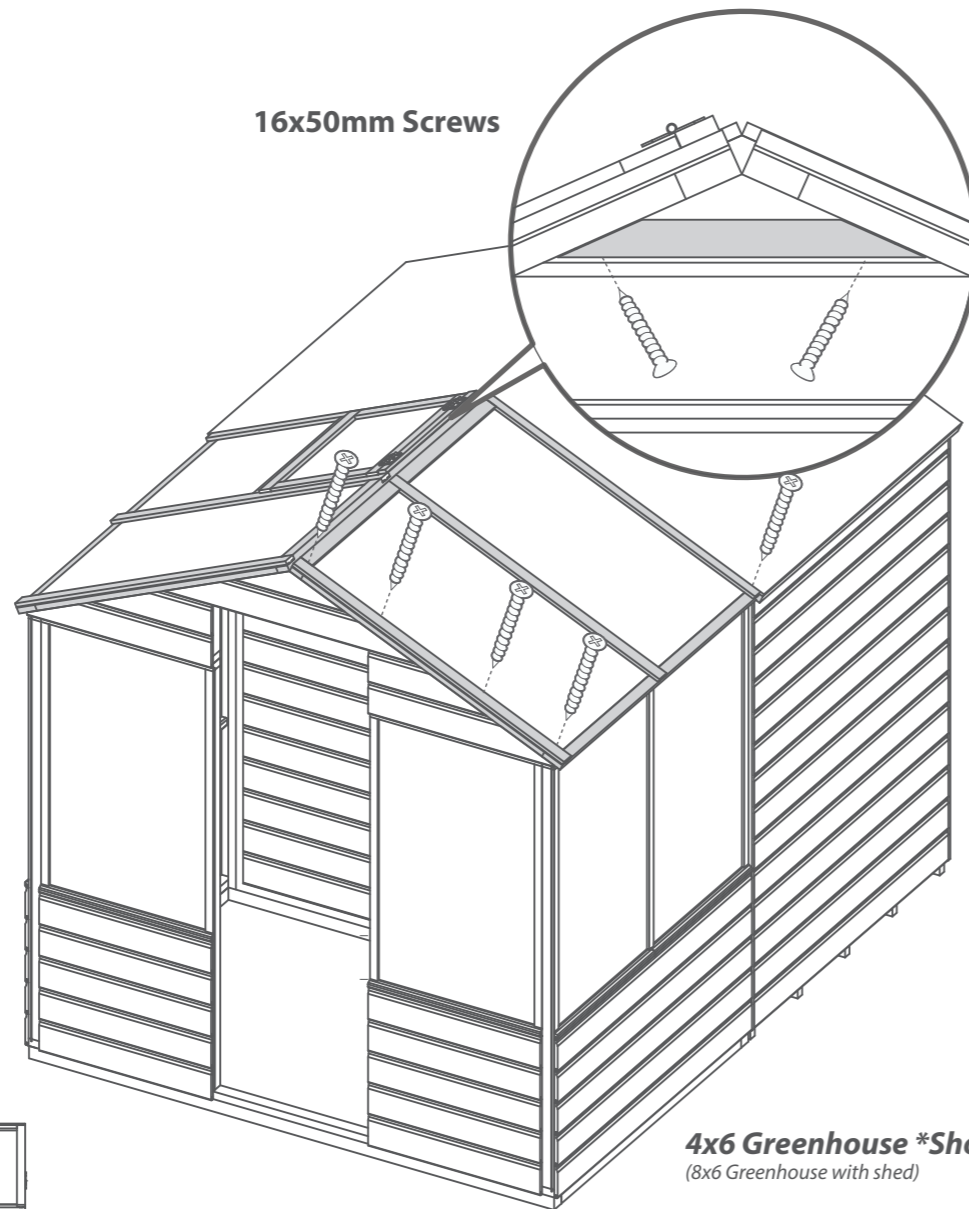
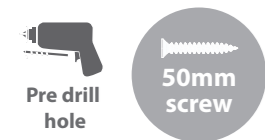

4x6 Greenhouse *Shown
(8x6 Greenhouse with shed)

Step 20 (internal)

Attach the roof support bar - **See greenhouse instructions** to the roof panels using 40mm screws.

Screw diagonally through the roof support bar into the panels as shown in the illustration.

See greenhouse instructions for screw quantities.

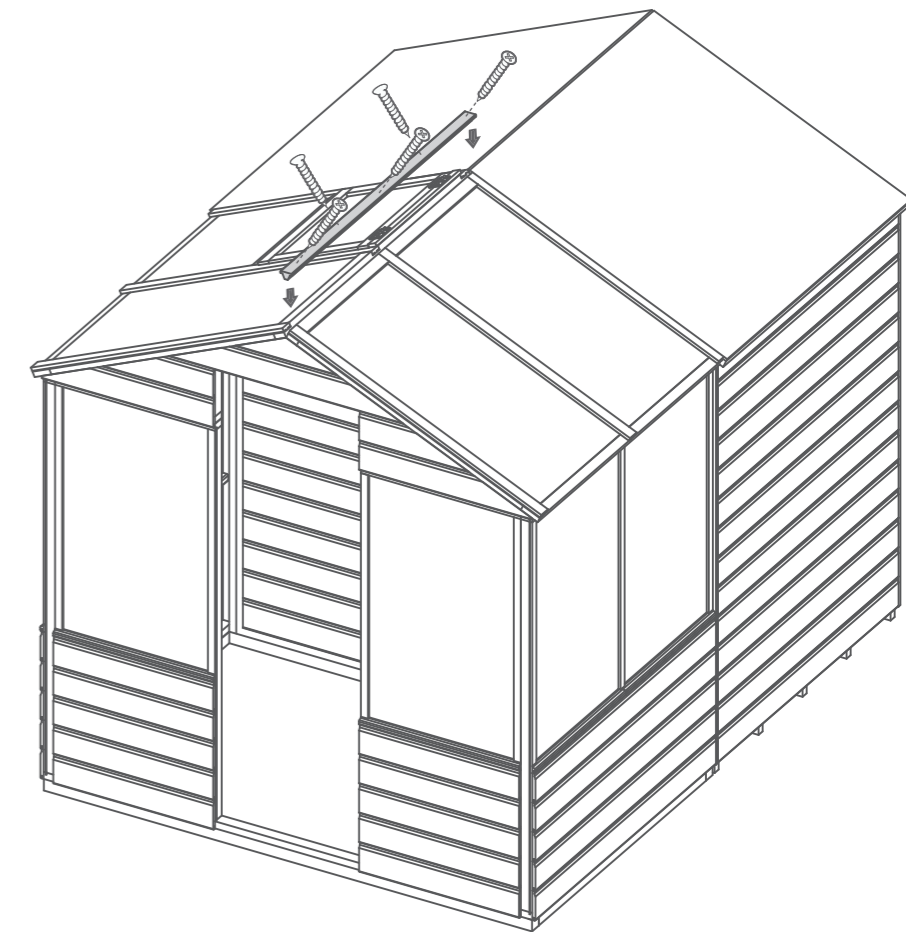
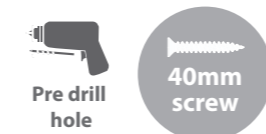

Step 21 (internal)

Fix the door to building using 16x16mm black screws.

Attach the turn buttons to the greenhouse door gable with 2x30mm black screws.

Place the door rail onto the base frame underneath the door and secure using 3x40mm screws

See greenhouse instructions for screw quantities.

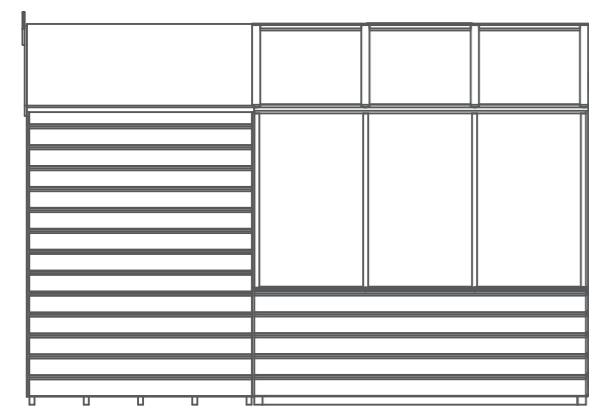
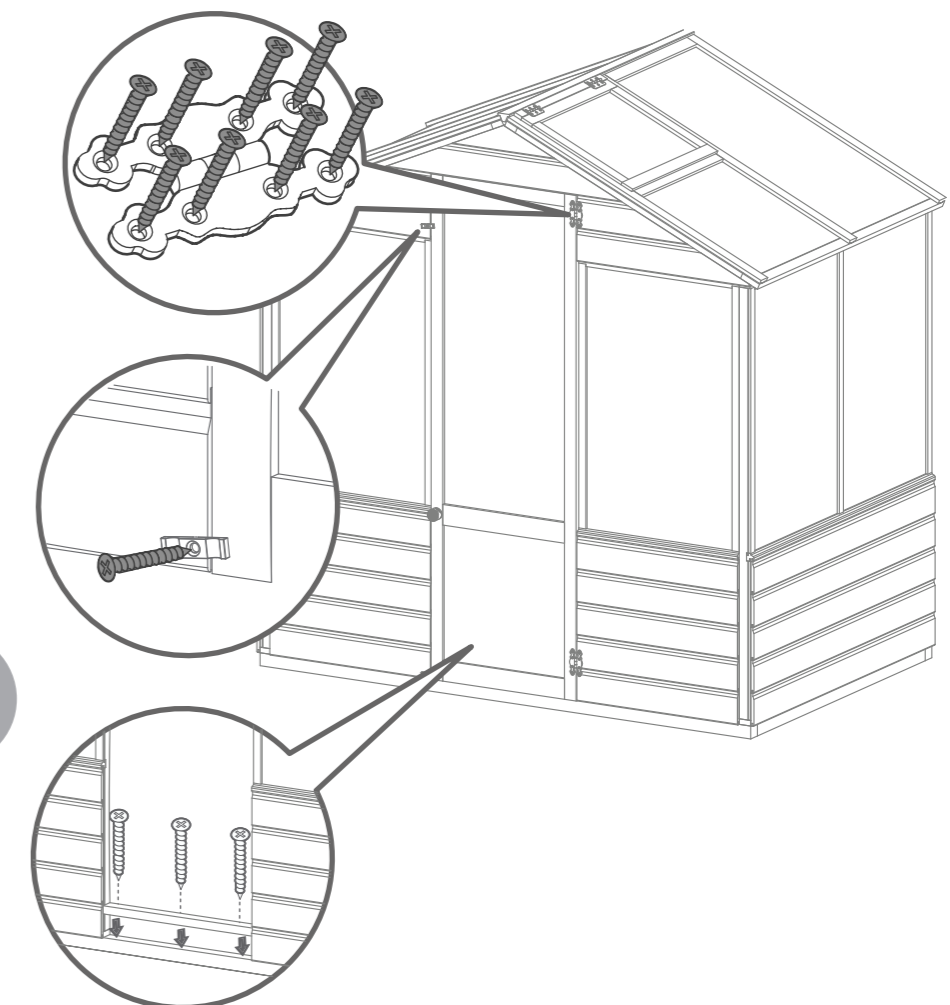
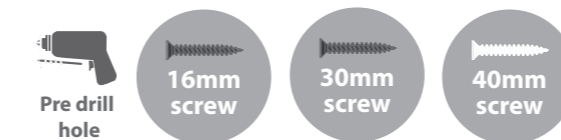

6x6 Greenhouse
(10x6 Greenhouse with shed)

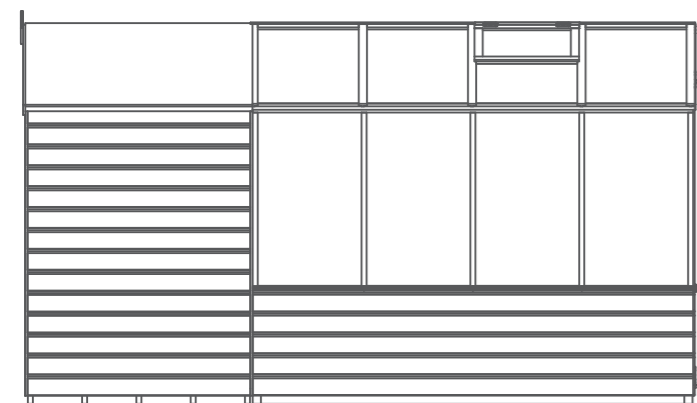

8x6 Greenhouse
(12x6 Greenhouse with shed)

Step 22 (internal)

Attach the fascia's from the greenhouse - See greenhouse instructions - to the front of the building using 6x40mm screws.

At the rear of the building (**Shed section**) fix the fascias (**No. 10**) to the gable with 40mm screws, making sure to trap the felt between the building and the fascia.

Secure the remaining two fascias (**No. 10**) - from the shed - across the joint of the two roofs, ensuring to screw to both the shed and greenhouse roofs using two screws at each end-point.

Fit the finials (**No. 15**) to the front and rear of the building with 2x40mm screws.

32x40mm screws



Pre drill hole



40mm screw

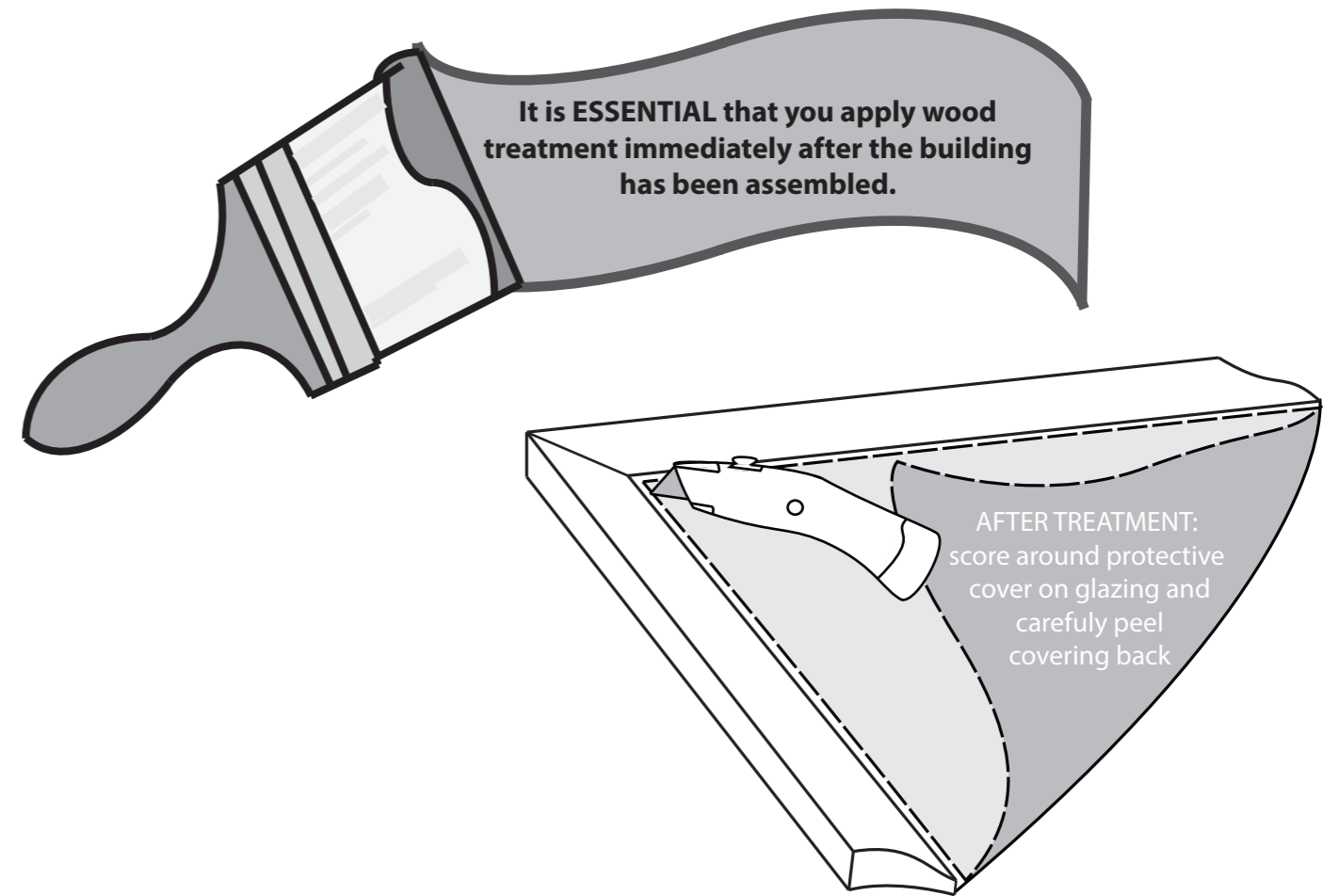
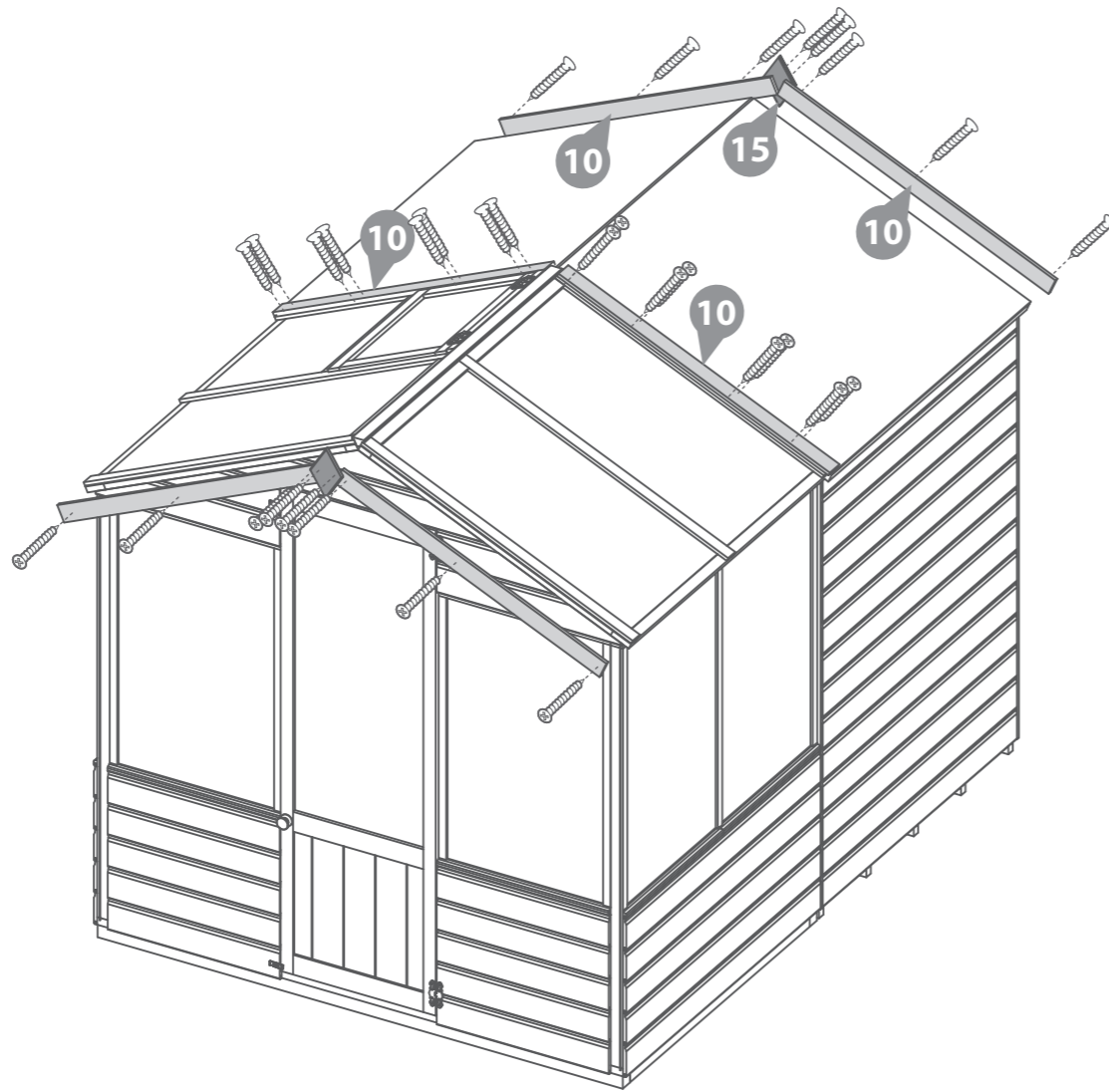

Step 23 (internal)

It is advisable to seal around all window framing with silicone sealant (**not included**) to minimize water ingress.

***Please note:** This image is for illustrative purpose and may differ from your product (**in regards to the number of windows**) however the principle is the same.

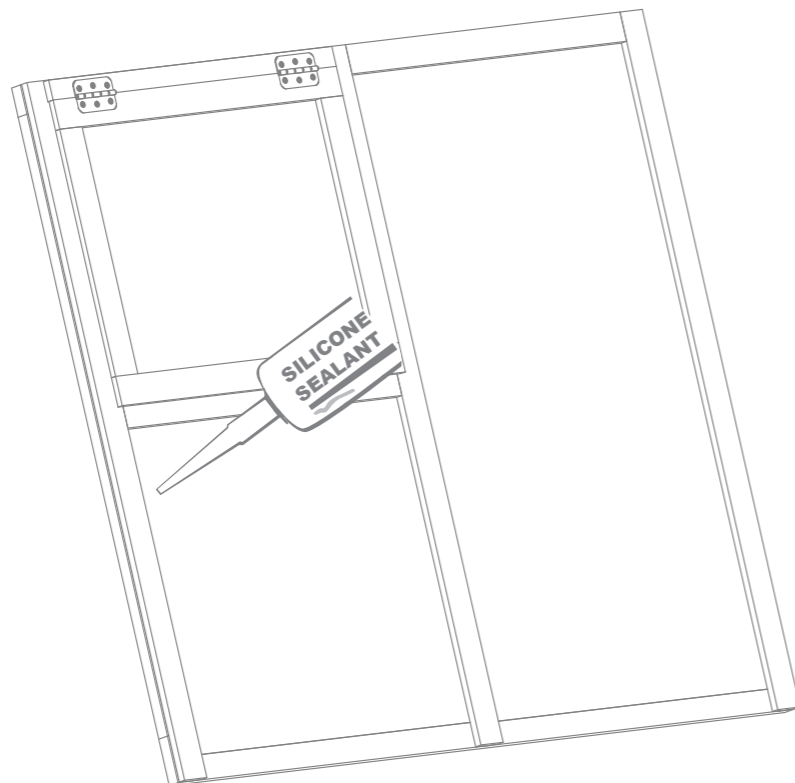

Instructions: External shed door option.

Step 23 (external)

Follow these instructions to **Step 10** to build the shed section.

**Ensure the shed is built so as the shed door will face away from the greenhouse door.*

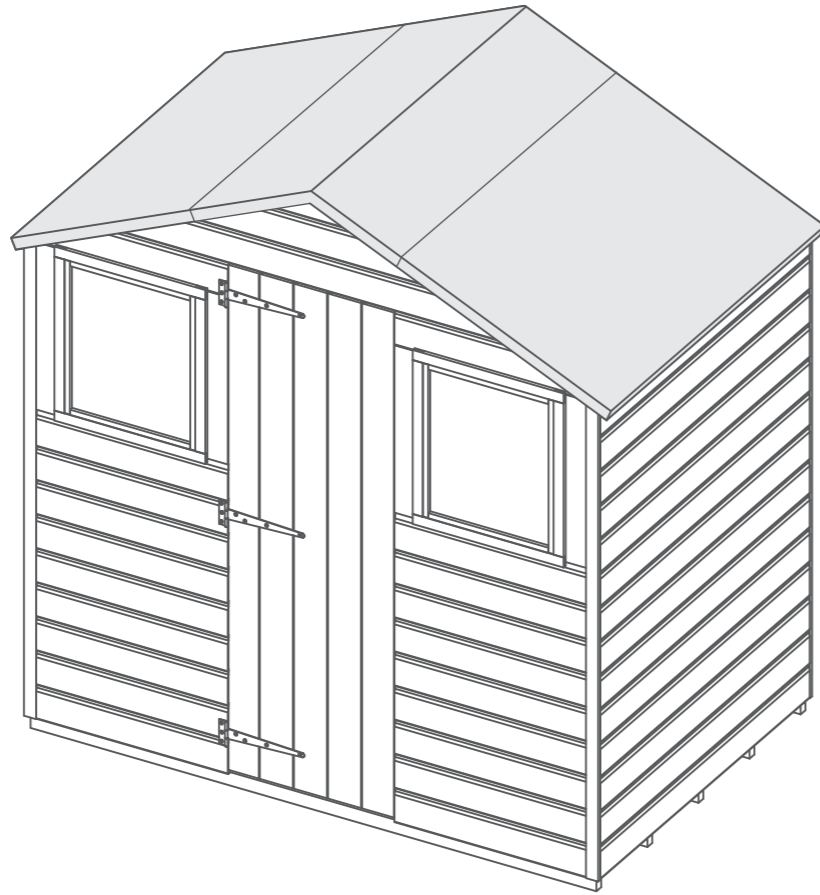

Step 25 (external)

Attach the last two cover strips (**No. 9**) to the back gable of the greenhouse using 3x30mm screws per strip.

**Measure the space between the bottom of the gable top & the bottom of the window panel and cut the strips to match before securing into position.*

6x30mm Screws



*Cut down trims to fit



Pre drill hole



30mm screw

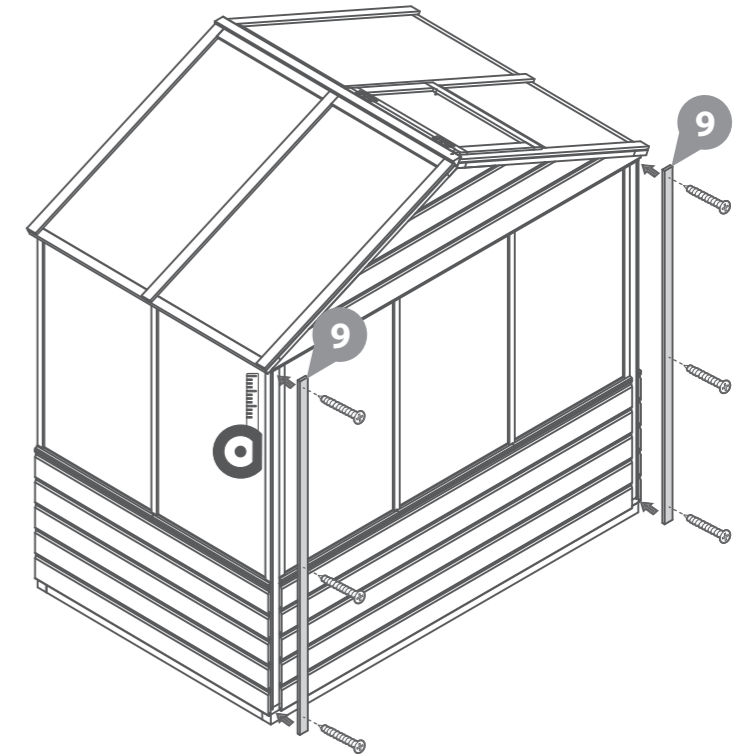

Step 24 (external)

Follow the instructions supplied with the greenhouse to build the next section.

**Do NOT attach the fascia's until after the building(s) have been connected.*

See greenhouse instructions for screw quantities.

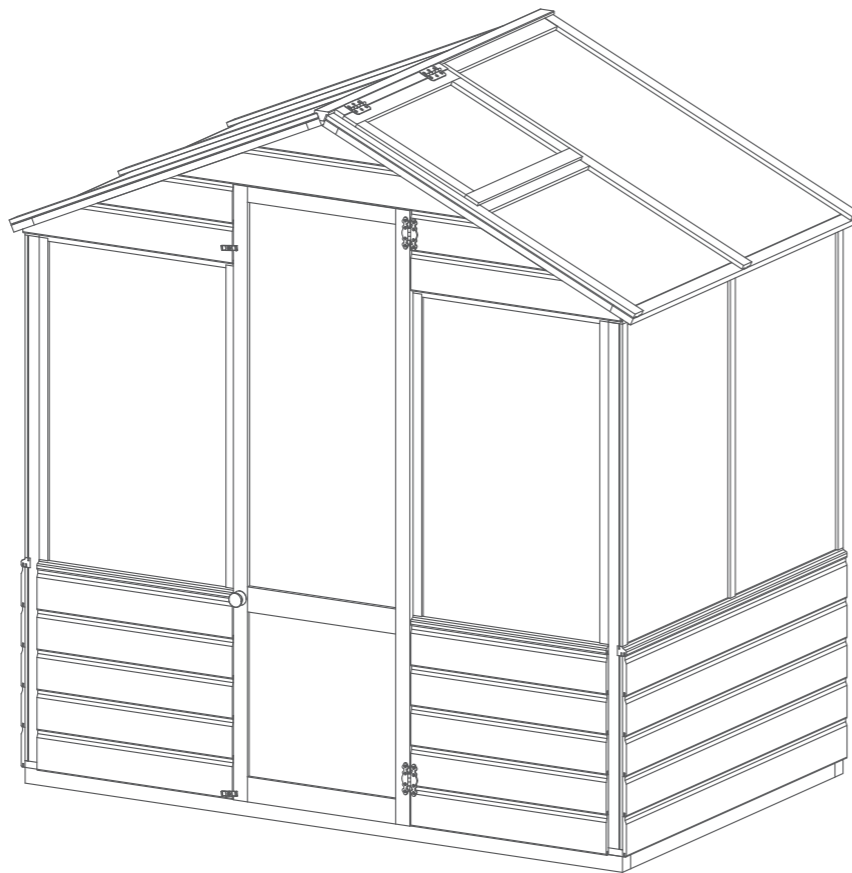

4x6 Greenhouse Shown

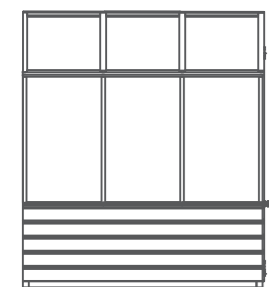

6x6 Greenhouse

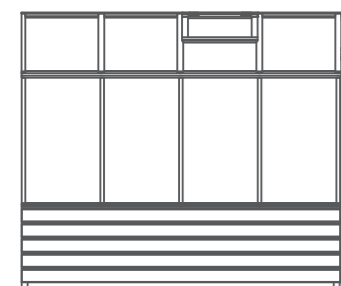

8x6 Greenhouse

Step 26 (external)

Once both buildings have been erected, secure the greenhouse to the shed section by screwing through the back of the greenhouse into the shed at each corner using 6x70mm screws as shown in the illustration.

6x70mm Screws

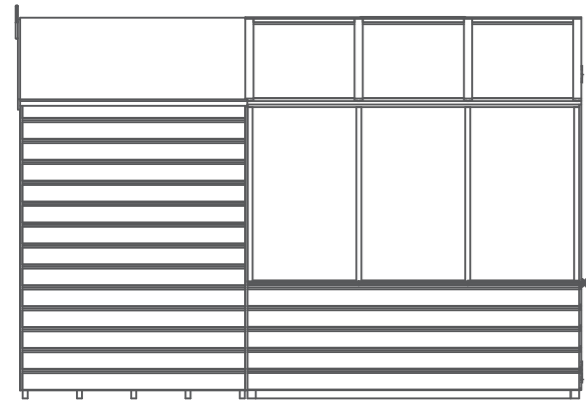
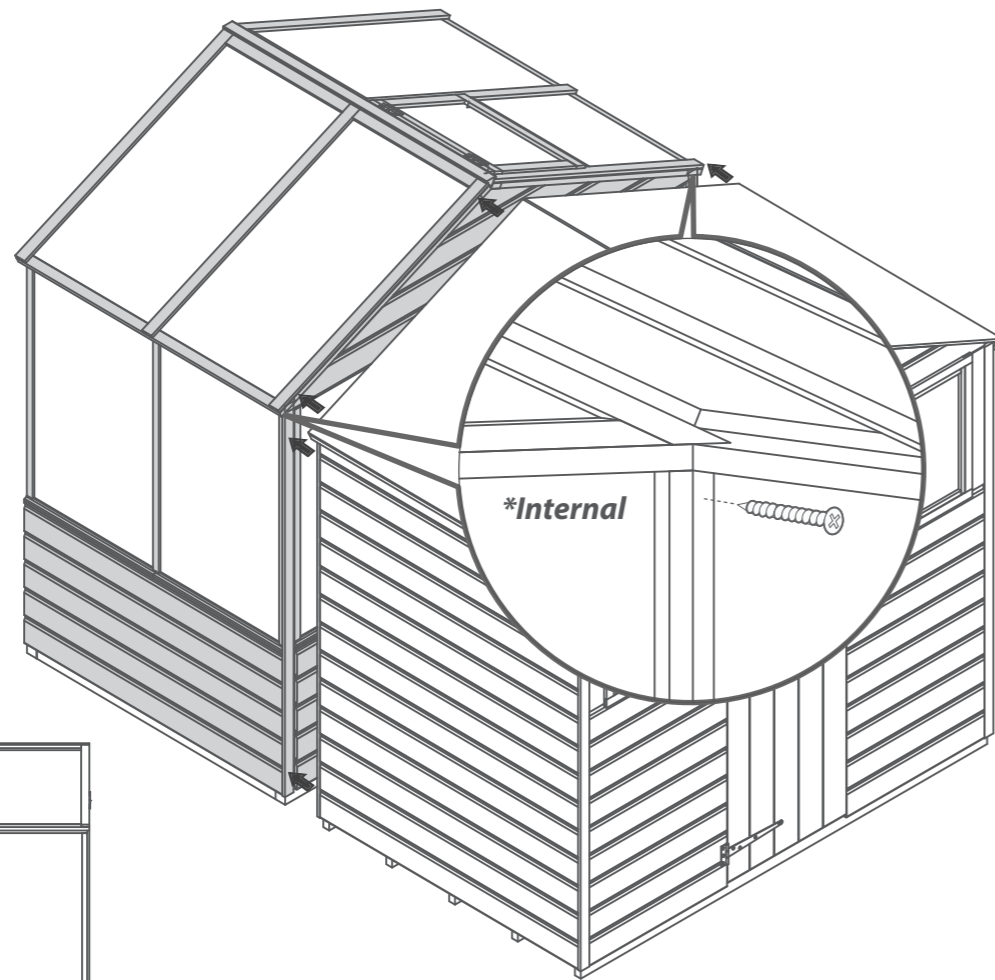
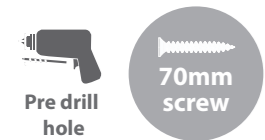

6x6 Greenhouse
(10x6 Greenhouse with shed)

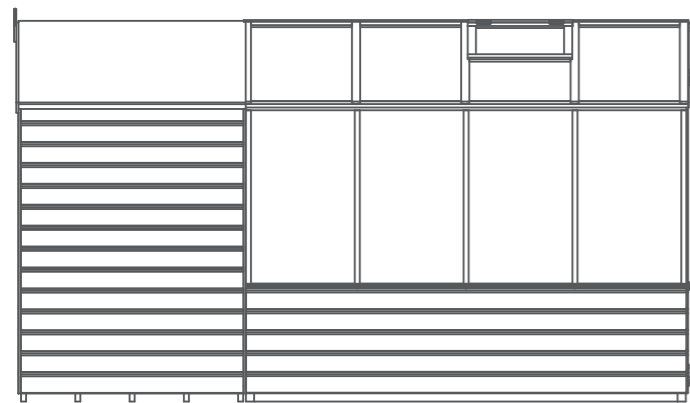

8x6 Greenhouse
(12x6 Greenhouse with shed)

Step 27 (external)

Attach the fascia's from the greenhouse - See greenhouse instructions - to the front of the building using 6x40mm screws.

At the rear of the building (**Shed section**) fix the fascias (**No. 10**) to the gable with 40mm screws, making sure to trap the felt between the building and the fascia.

Secure the remaining two fascias (**No. 10**) - from the shed - across the joint of the two roofs, ensuring to screw to both the shed and greenhouse roofs.

Fit the finials (**No. 15**) to the front and rear of the building with 2x40mm screws.

26x40mm screws

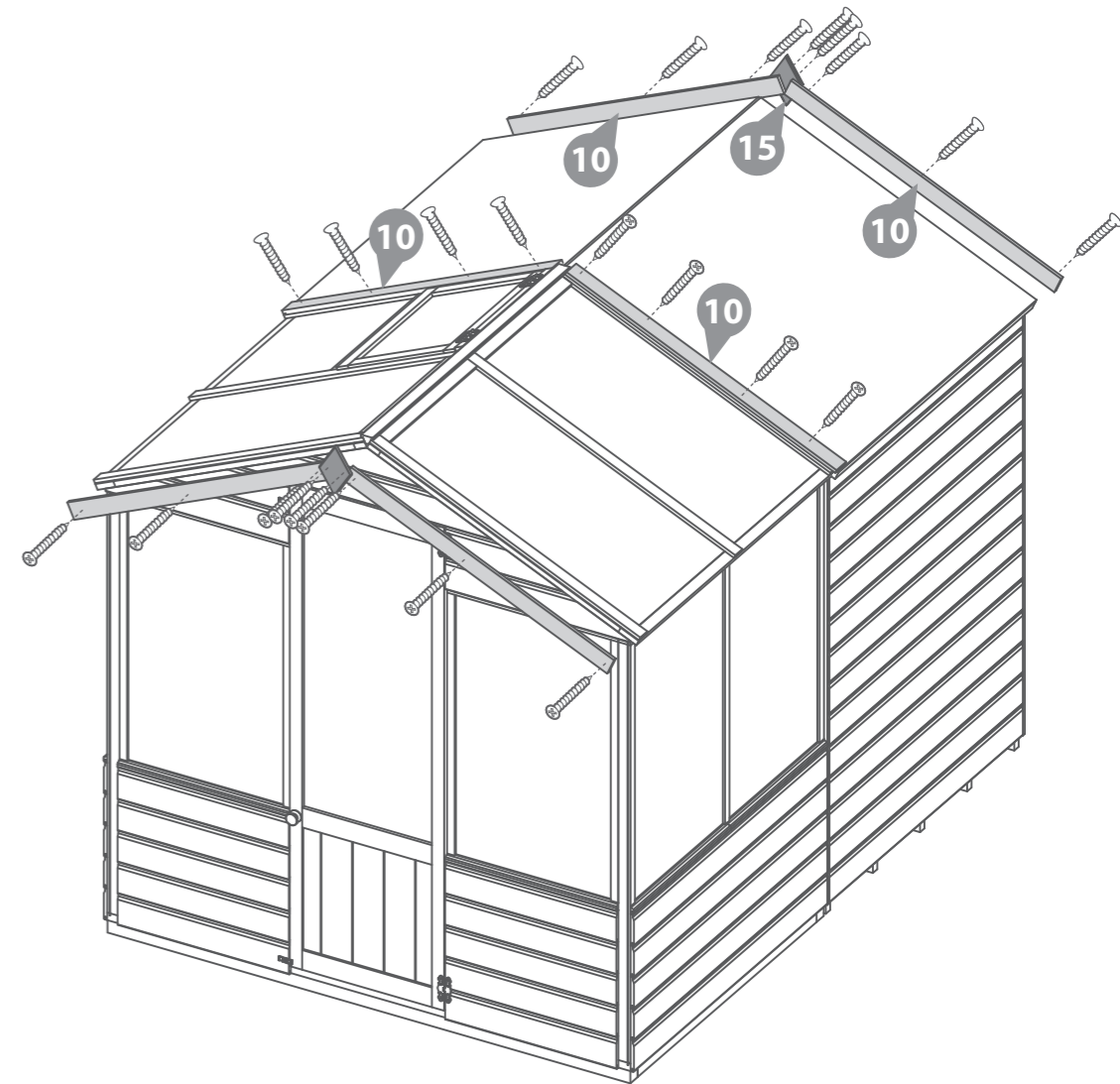
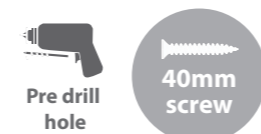

Step 28 (external)

It is advisable to seal around all window framing with silicone sealant (**not included**) to minimize water ingress.

**Please note: This image is for illustrative purpose and may differ from your product (in regards to the number of windows) however the principle is the same.*

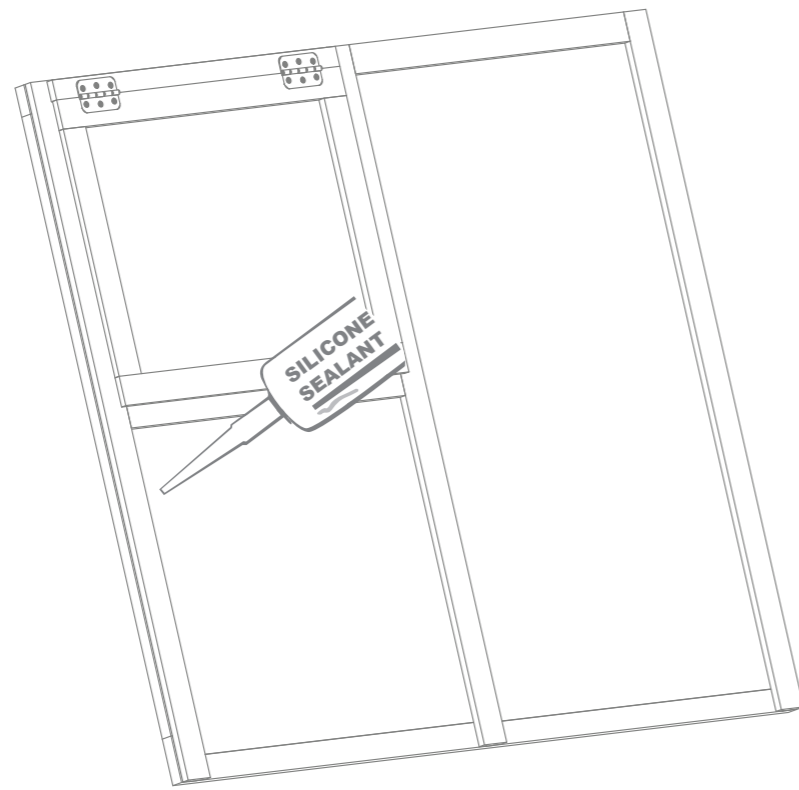

It is **ESSENTIAL** that you apply wood treatment immediately after the building has been assembled.



AFTER TREATMENT:
score around protective cover on glazing and carefully peel covering back

