

Z52JCC1N6

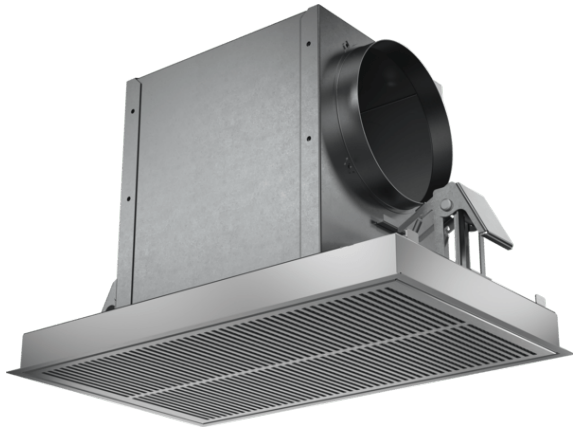

COOKING PASSION SINCE 1877



Features

Technical Data

Dimensions of the packed product (HxWxD) (mm) : 450 x 600 x 400

Pallet dimensions : 195.0 x 80.0 x 120.0

Standard number of units per pallet : 12

Net weight (kg) : 5.154

Gross weight (kg) : 6.3

EAN code : 4242004244929



Features

Optional accessories

- Clean Air Plus recirc. kit external inox
- Colour: stainless steel
- For recirculation operation
- Combined with ceiling hoods
- Anti-fish functionality: Especially effective against fish smell.
- Connection pipe front, side or top

Dimensioned drawings

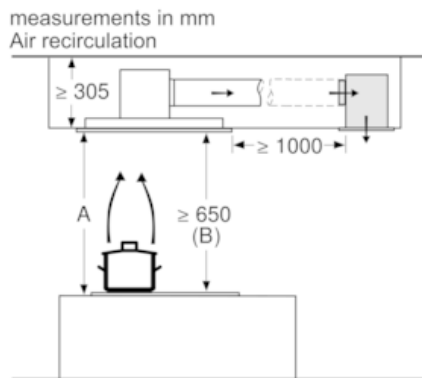

A: Optimum performance 700-1500
B: From upper edge of pan support