

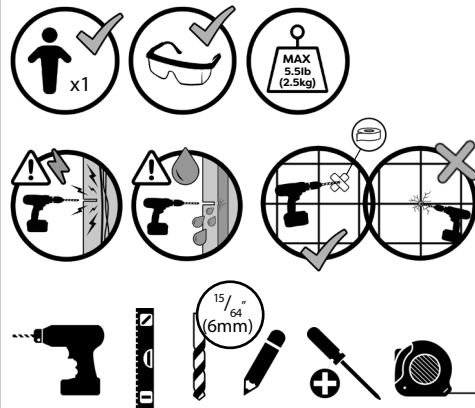

Follow these instructions when using the adhesive fixing method.



### Warning

The adhesive is suitable for use on most flat finished surfaces, such as gloss paint, tiles, polished stone, laminates and textured surfaces. **DO NOT USE ON DECORATIVE WALL PAPER FINISHES.** The adhesive is **NOT** suitable for unfinished materials such as brick, block-work, wood, emulsion paint, loose, flaky surfaces or surfaces contaminated with grease, wax or dust.



**PLEASE TURN OVER FOR MORE SAFETY AND CARE INSTRUCTIONS.**

**1** Clean chosen area with warm soapy water

Dry area thoroughly with a clean towel

**2** Unscrew the cap and disassemble the bracket.

**3** Using a pencil mark around the intended positions of the brackets. Ensure they are level.

Measure Towel Rail Centres

**4** Expose the adhesive by peeling away the red protective film.

**5** Press & Hold for 30 seconds. LEAVE FOR 24 HOURS BEFORE USE.

**6** Reassemble the bracket/s with the product attached (step 1).

**7** Reassemble the bracket/s with the product attached (step 2). Make sure to tighten the caps firmly. DO NOT OVER TIGHTEN.

For drilling instructions please turn over.



+44 (0) 1264 365881



+44 (0) 1264 356437



info@croydex.co.uk



www.croydex.com

SNL 014 R02

UK: Croydex, Central Way, Andover, Hampshire, SP10 5AW, UK

EU: MIL, Unit 8 Purcellsinch Ind Est, Dublin Road, Kilkenny, R95 HP71, Ireland



Follow these instructions when drilling new holes.

### Safety & Care

1. Always take care when using power tools, especially if there is any water in the working area.
2. When drilling into a tiled surface do not use a hammer drill.
3. Always use a residual current circuit breaker (RCCB/GFCI)
4. Always use a drill bit that is suitable for the surface that is being drilled.
5. The wall plugs supplied are for use on solid walls only. For cavity walls or plasterboard use specialist fixings that are suitable for the type of wall construction.
6. To retain the best quality finish, clean product regularly with a soft damp cloth.
7. Do not use abrasive or chemical cleaners, as these may damage the product.
8. Redecoration may be required on some painted surfaces after removal.
9. The maximum safe working load is 5.5 lb (2.5kg) distributed evenly. **DO NOT OVERLOAD.**
10. Do not use tile cleaning chemicals on or around this product as they may affect adhesion.

### 5 Year Anti-corrosion Guarantee

This product is guaranteed against corrosion for 5 years. Please retain a copy of your receipt which must be presented should a guarantee claim be necessary. This guarantee covers corrosion under normal usage, when the product is installed, used and cleaned in accordance with these instructions. This guarantee does not cover corrosion resulting from damage to the protective coating due to the use of abrasive sponges or pads, abrasive cleaners, strong chemical cleaners or metal polish. In the unlikely event that corrosion should occur during the guarantee period we will replace the product.



**PLEASE TURN OVER FOR MORE PRE-INSTALLATION INSTRUCTIONS.**

1 Unscrew the cap and disassemble the bracket.

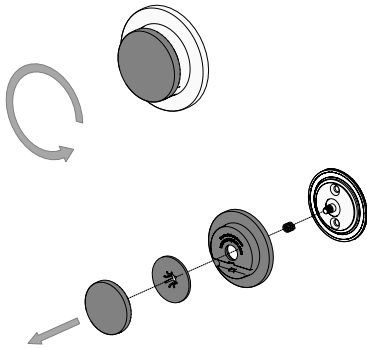

2 Using the screw, pierce through the plastic and the adhesive tape.

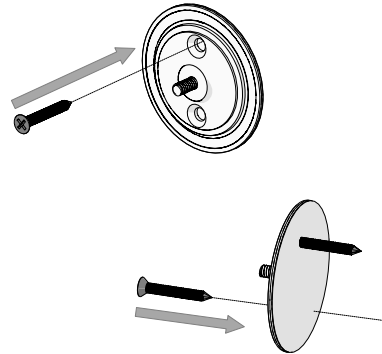

3 Using a pencil mark the holes for the intended positions of the brackets. Ensure they are level.

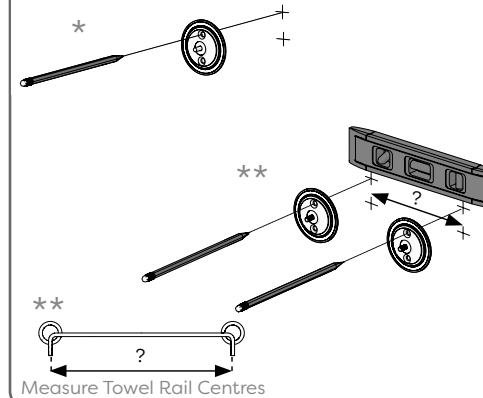

4 Using a  $\frac{15}{64}$ " (6mm) drill bit, drill the holes marked.

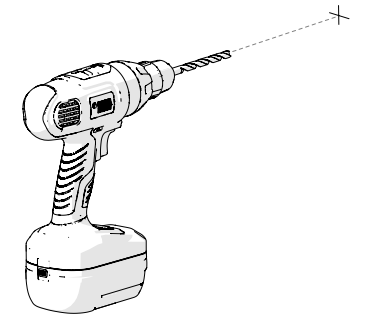

5 Insert the wall plugs into the holes and then screw the back plates to the wall.

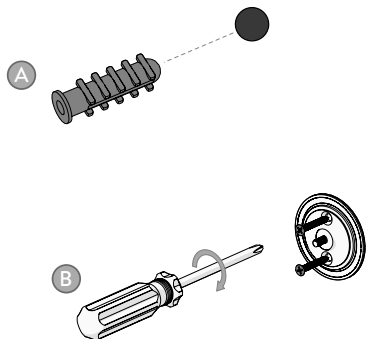

6 Reassemble the bracket/s with the product attached (step 1).

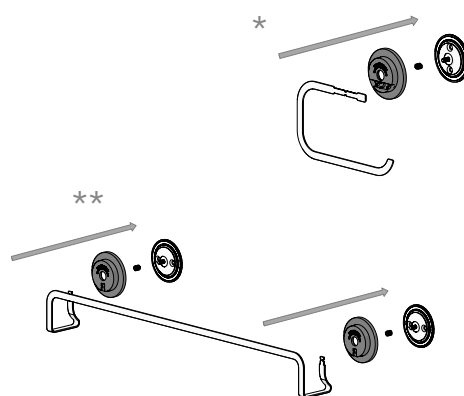

7 Reassemble the bracket/s with the product attached (step 2). Make sure to tighten the caps firmly. **DO NOT OVER TIGHTEN.**

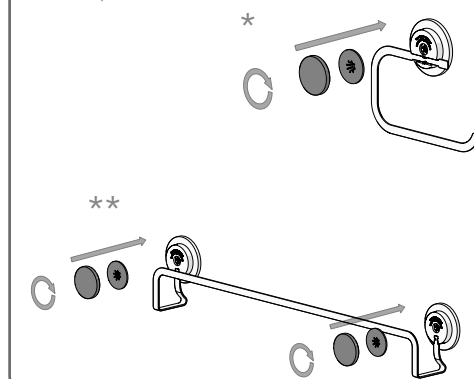

For adhesive instructions please turn over.

UK: Croydex, Central Way, Andover, Hampshire, SP10 5AW, UK  
EU: MIL, Unit 8 Purcellsinch Ind Est, Dublin Road, Kilkenny, R95 HP71, Ireland



+44 (0) 1264 365881



+44 (0) 1264 356437



info@croydex.co.uk



www.croydex.com

SNL 014 R02