

CE	
Merlyn Industries Ltd (MER13)	
CEBH1.1	
18	
EN 14428	
Shower enclosures with aluminium profiles and safety glass	
Cleanability	: Pass
Impact resistance/ shatter properties	: Pass
Durability	: Pass

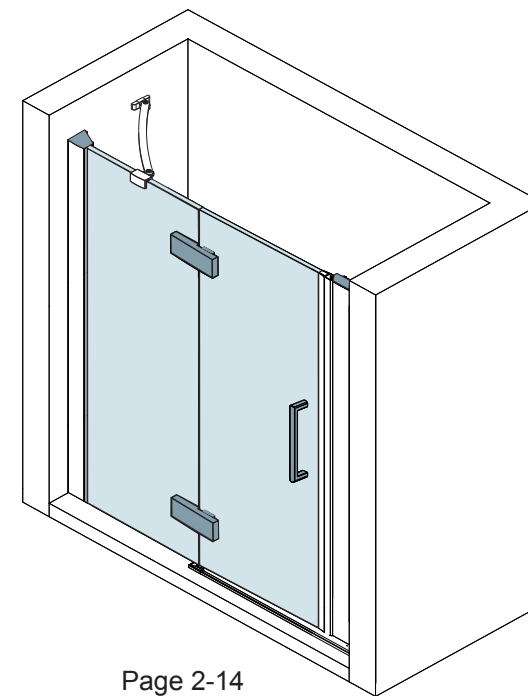

Page 2-14

HINGE DOOR IN A RECESS

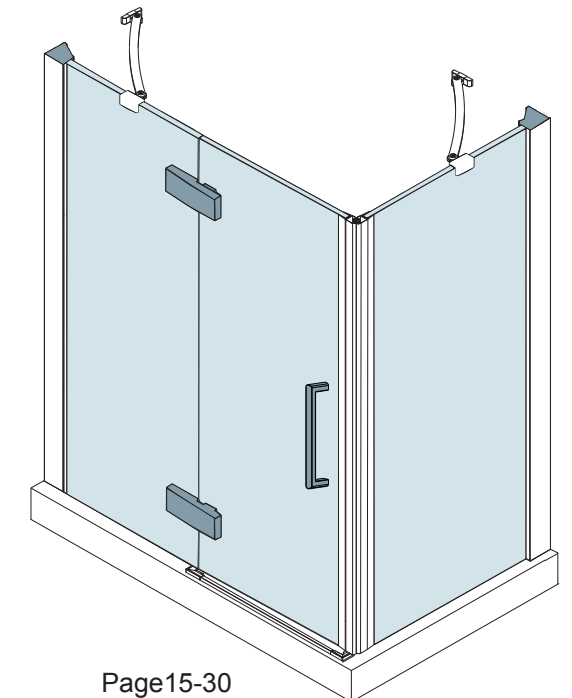

Page 15-30

HINGE DOOR WITH SIDE PANEL

To download the Declaration of Performance (DOP) for this product please use the link below.

<http://merlynshowering.com/aftersales-support/dop-certs/>

For further information please contact IRL: 056 7791 555, UK: 08081011429

HINGE DOOR IN A RECESS

IMPORTANT

Thank you for choosing Merlyn. Please familiarise yourself with the fitting instructions before commencing fitting.

- 1 Check that you have the tools required
- 2 Check that the installation site is compatible with size of door supplied
- 3 Check all the enclosure components
- 4 Check that the installation kit is complete

DO NOT attempt to install the product unless you can tick **ALL 4** boxes as satisfactory.
The wall plugs supplied with the installation kit are for use in solid walls. Hollow or 'stud - partition' walls will require alternative fixings. Please consult a hardware supplier for the correct type.
It may also be necessary to consult your tiling supplier about the correct method for drilling your tiles.

USE SAFETY EYEWEAR WHEN DRILLING

Any parts missing or damaged must be reported to your supplier within 5 days of purchase. Inspect shower enclosure before fitting. No claims will be accepted after product has been installed.

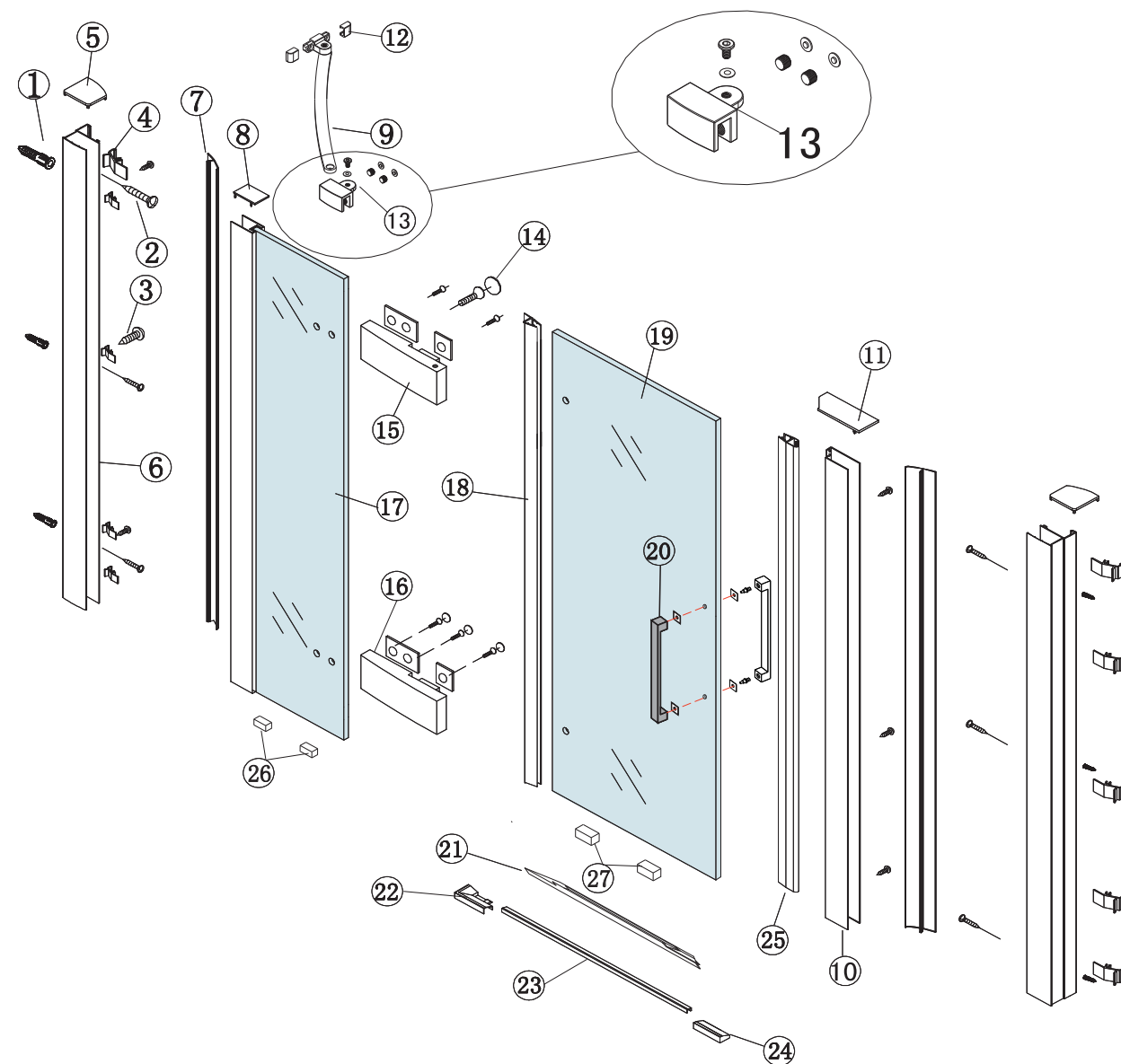

No.	Qty	Description	Part No.	No.	Qty	Description	Part No.	No.	Qty	Description	Part No.
①	8	Wall plug	SP0D1123	⑩	1	Magnet profile	A01S0180B	⑲	1	Moving panel	B
②	8	Pan head screw 4 x 30	SP0D0ST430	⑪	1	Magnet profile cover cap	A01S0189B	⑳	1	Handle	A01S0126B
③	6	Pan head screw 4 x 12	SP0D0ST412	⑫	2	Bracing bar cover cap	A01S0619B	㉑	1	Bottom seal	A01S0605B
④	10	Cover strip clip	A01S0116	⑬	1	Bracing bar clamp	A01S0617B	㉒	1	Fixed panel footplate	A01S0210B
⑤	1	Wall profile cover cap	A01S0190B	⑭	6	Hinge cover cap	SP0D2019B	㉓	1	Threshold	A01S0182B
⑥	2	Wall profile	A01S0177B	⑮	1	Hinge 1	A01S0206B	㉔	1	Closing post footplate	A01S0211B
⑦	2	Cover strip	A01S0115B	⑯	1	Hinge 2	A01S0207B	㉕	1	Magnet seal set	A01S0635B
⑧	1	Upright profile cap	A01S0188B	⑰	1	Fixed panel	C	㉖	2	Fixed panel block	A06S0063
⑨	1	Bracing bar	A	⑱	1	Moving panel hinge seal	A01S0633B	㉗	2	Moving panel spacer	A01S0213

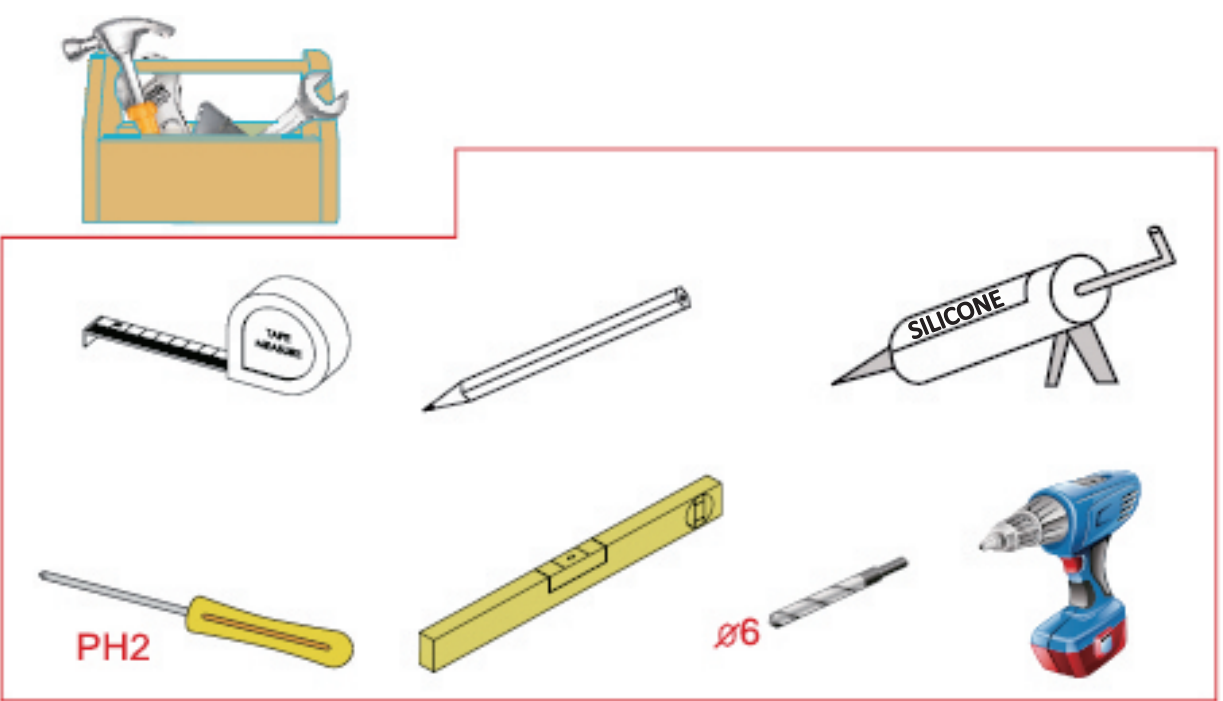
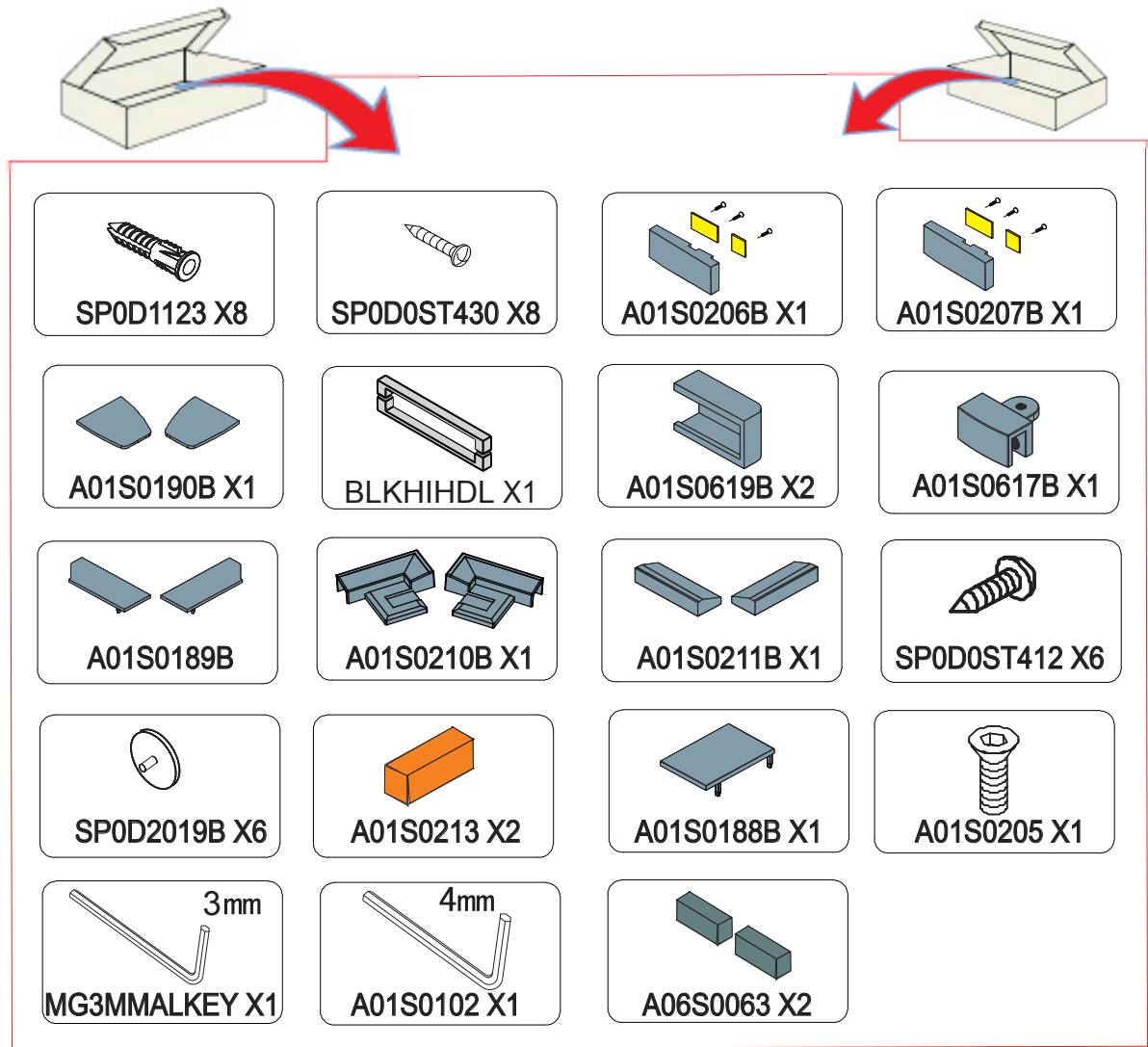

4.

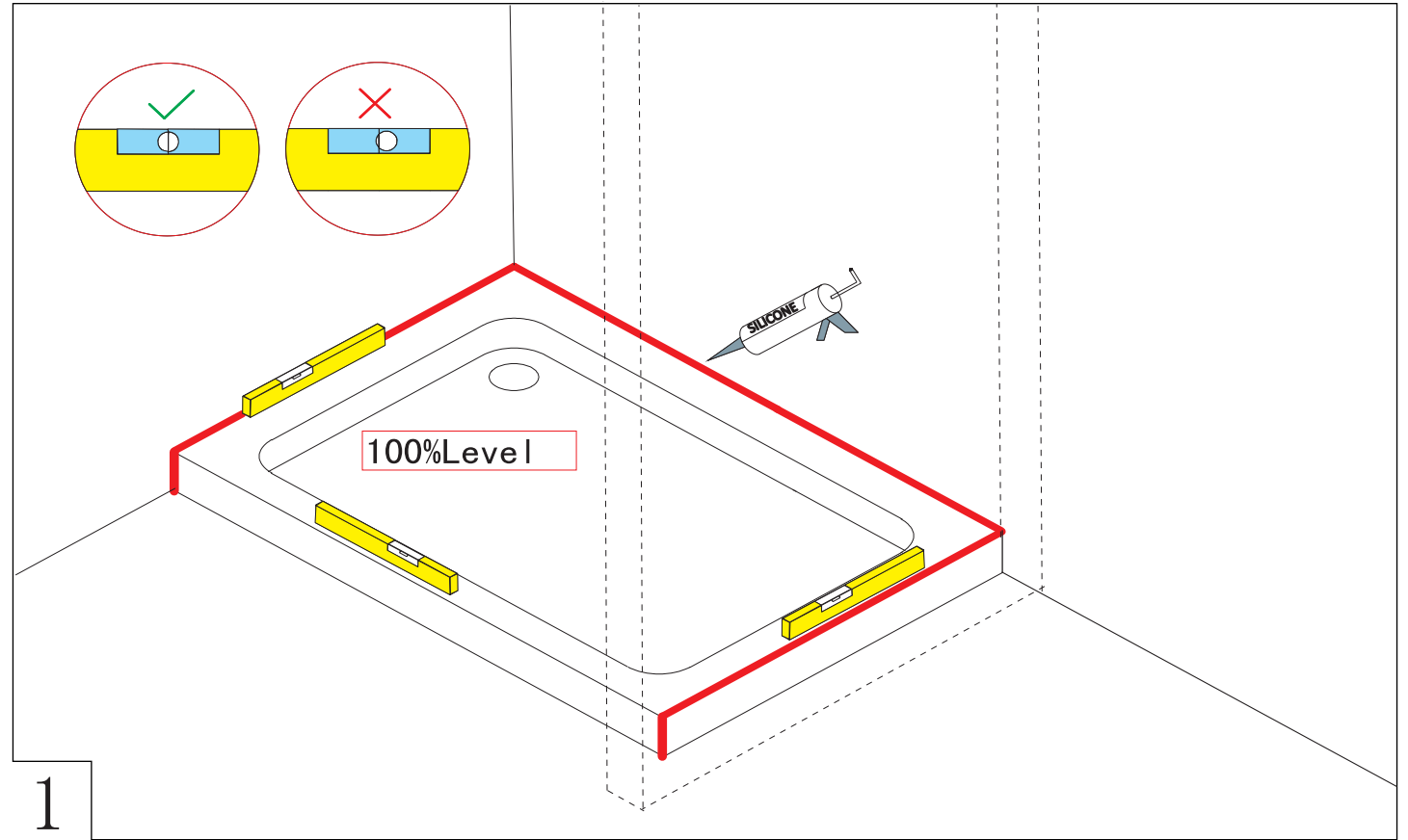

1

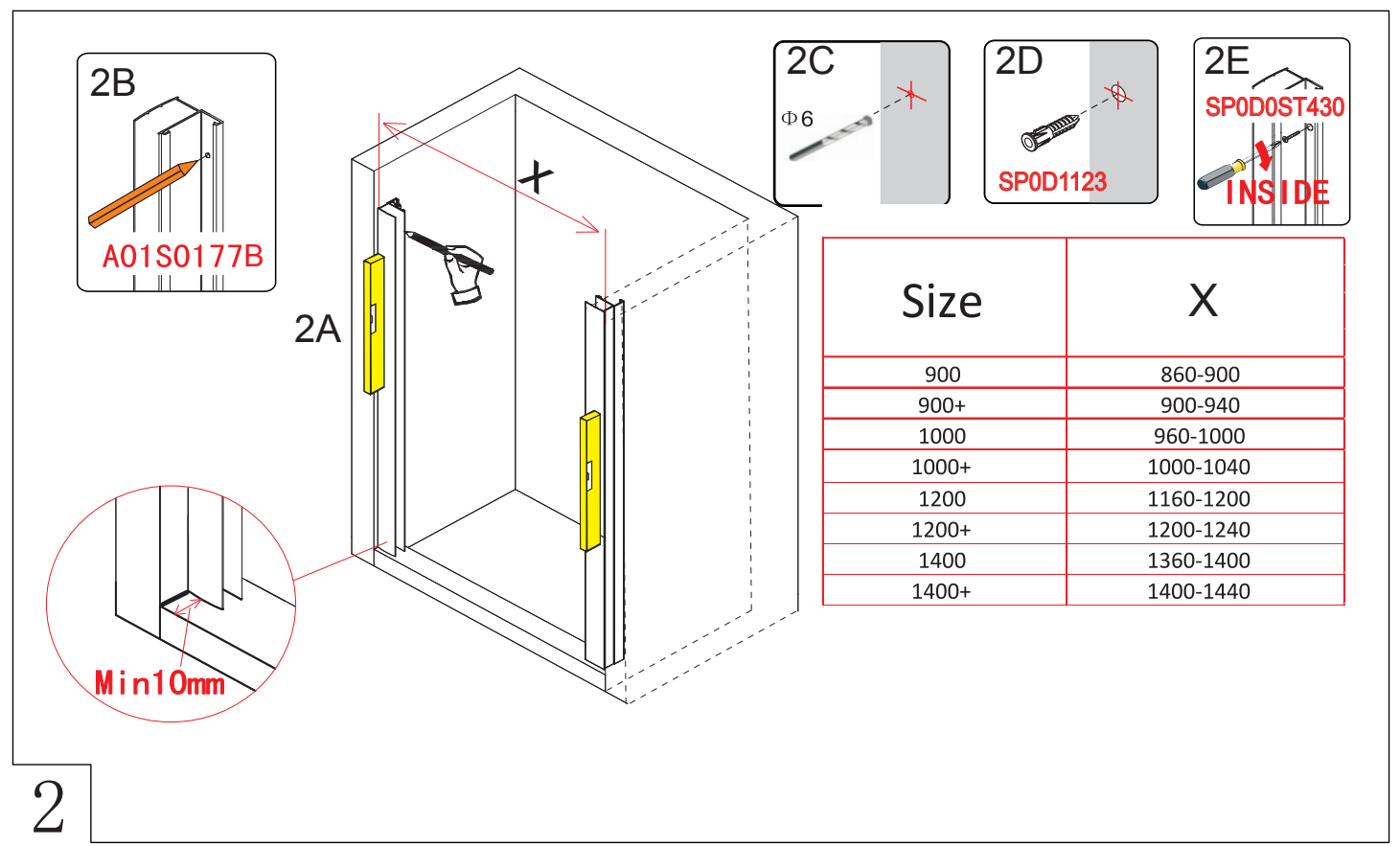

2

5.

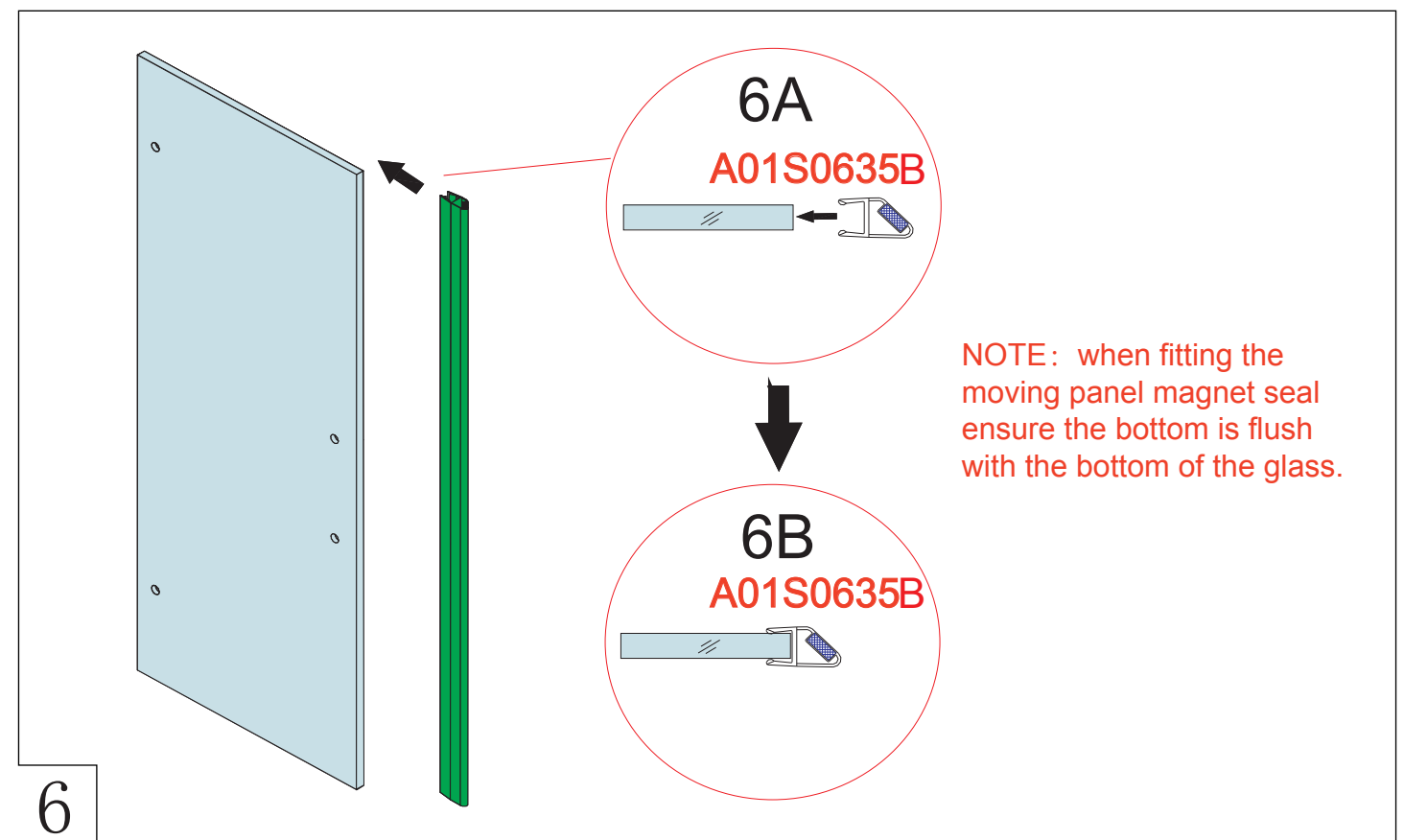
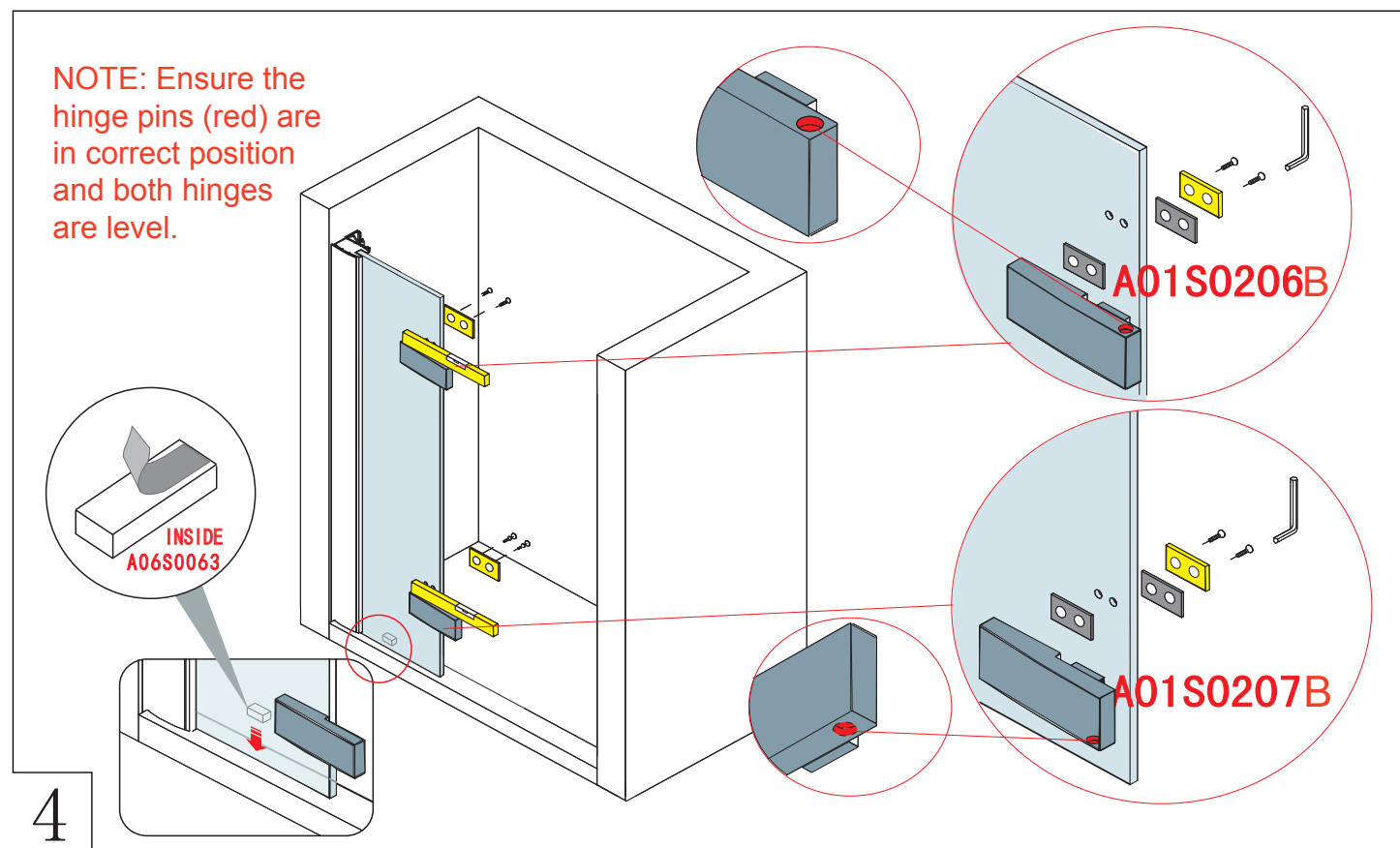
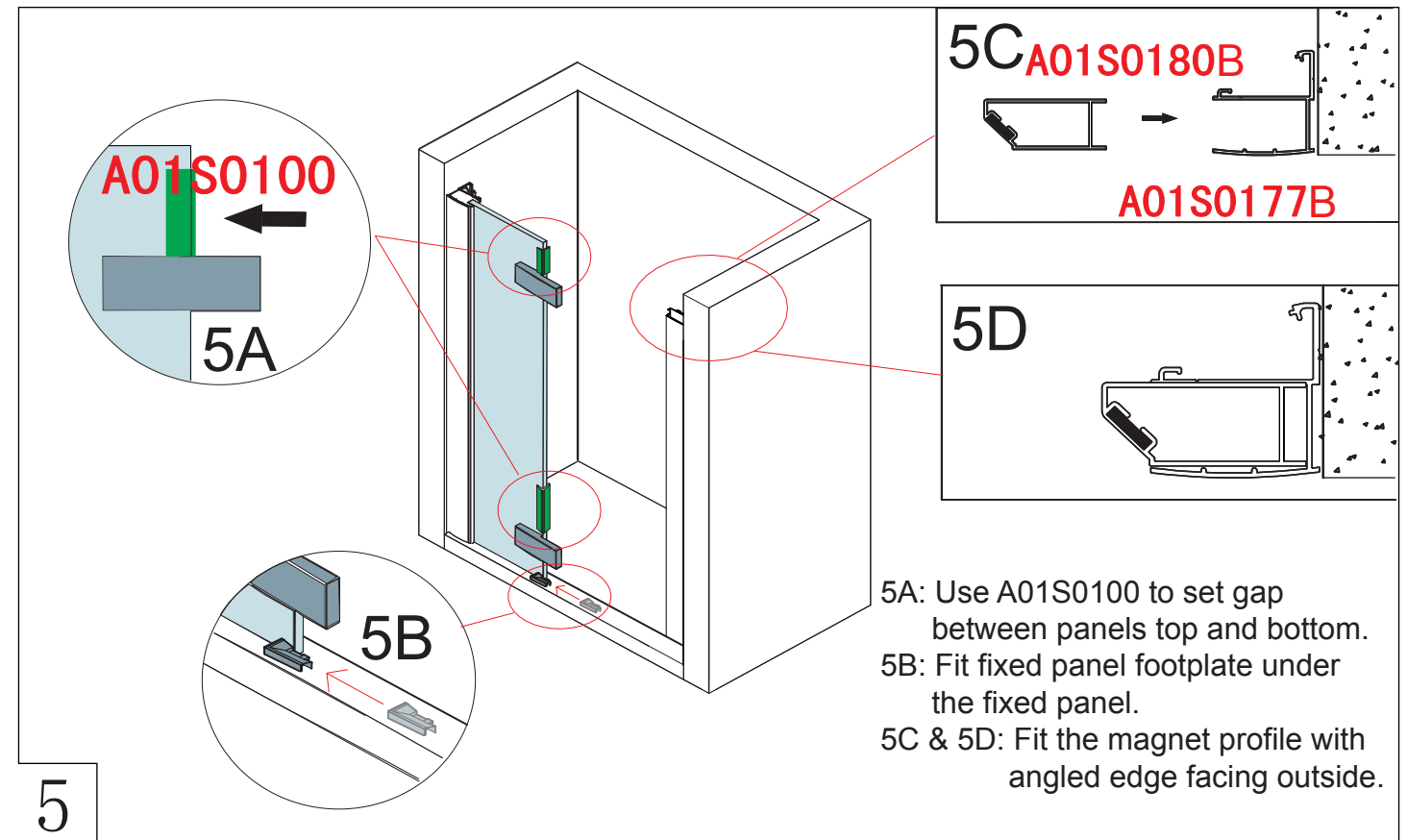
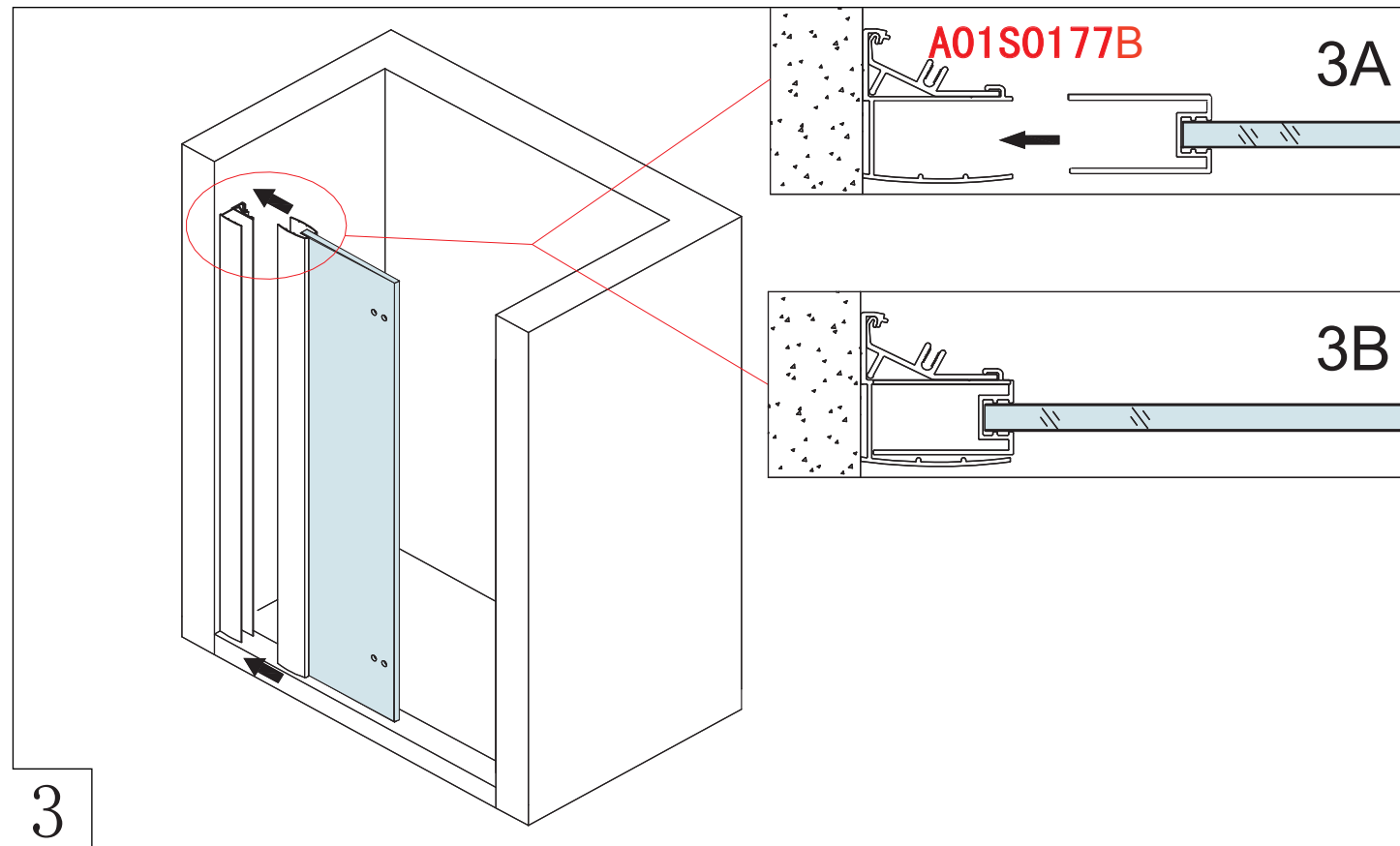

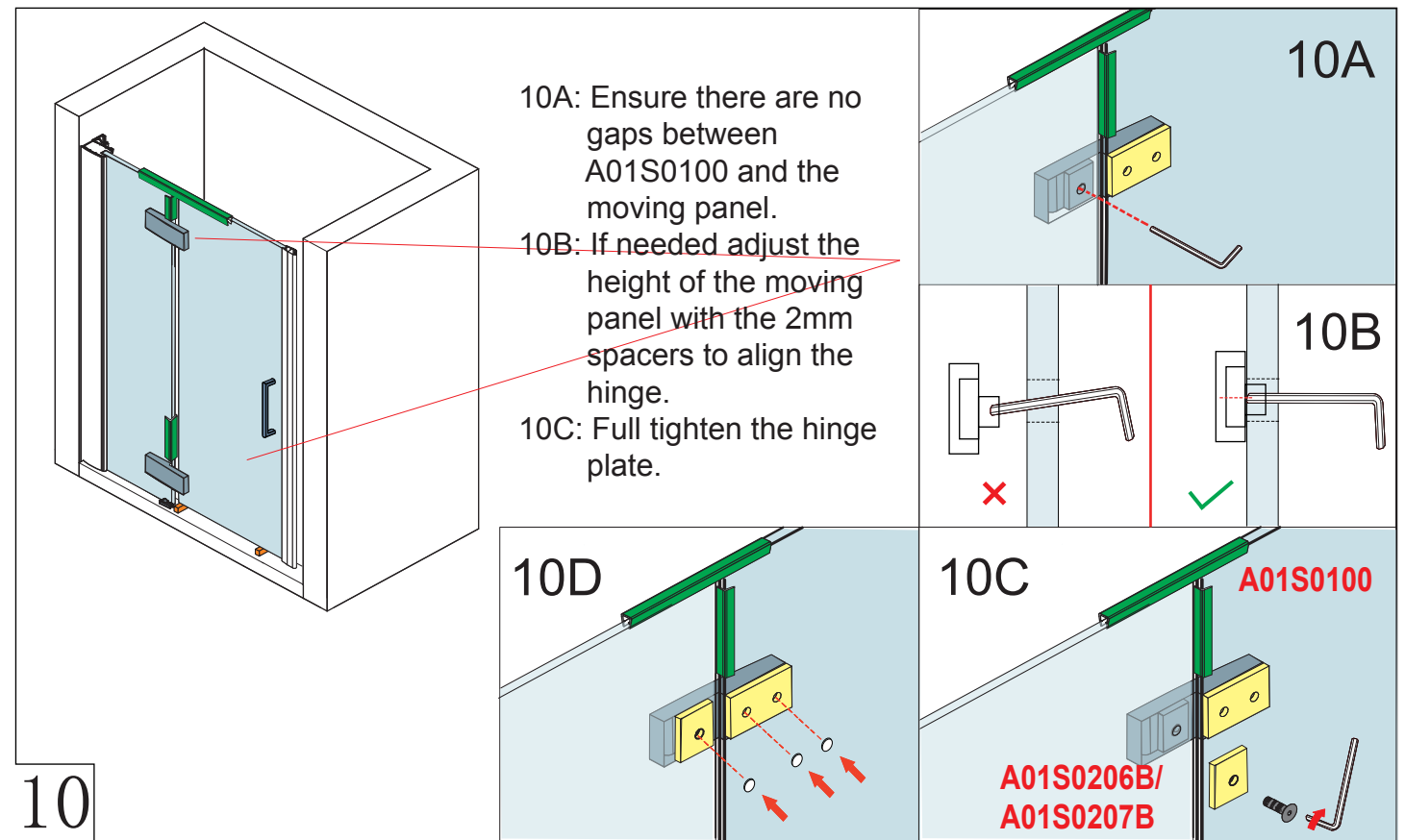
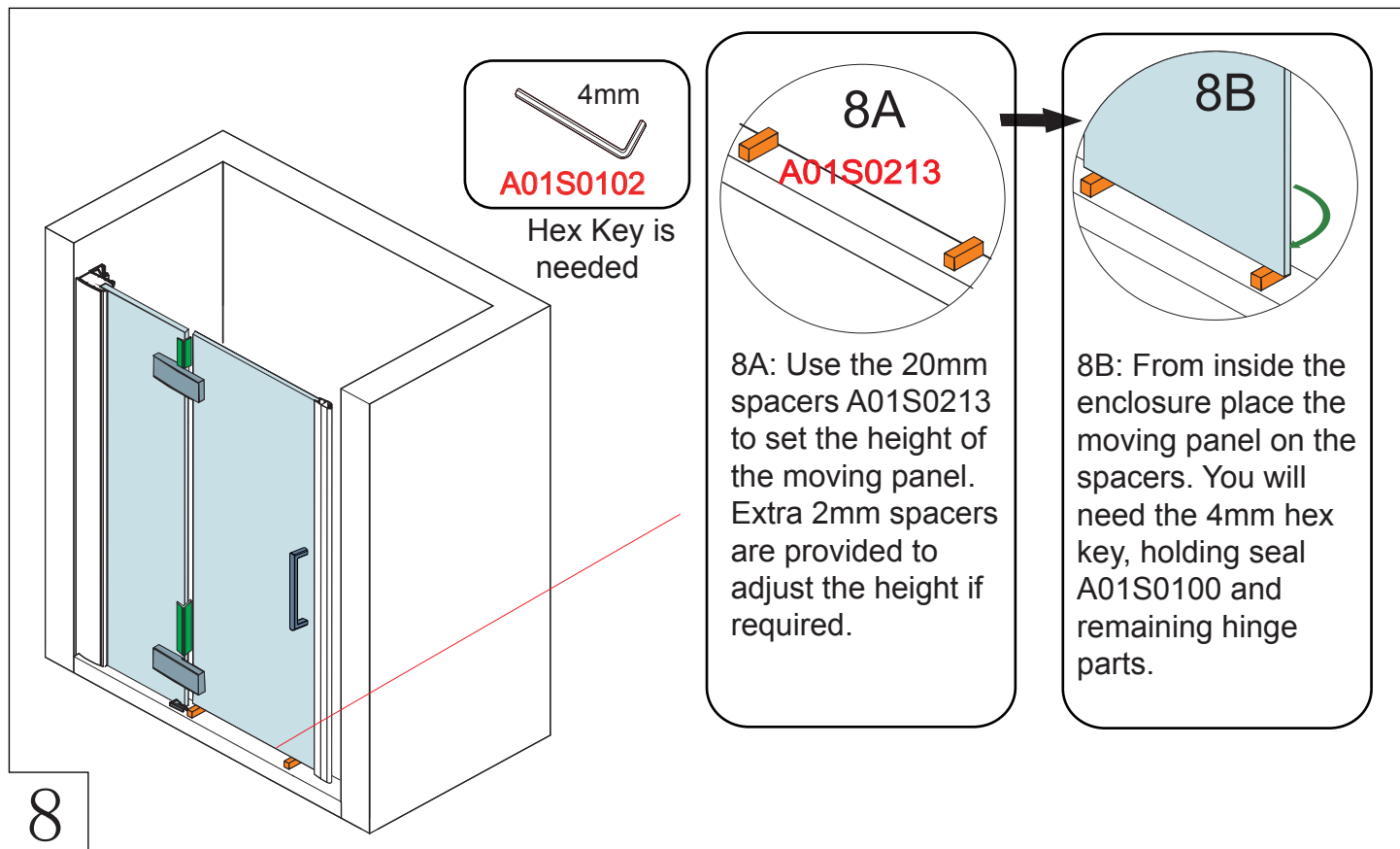
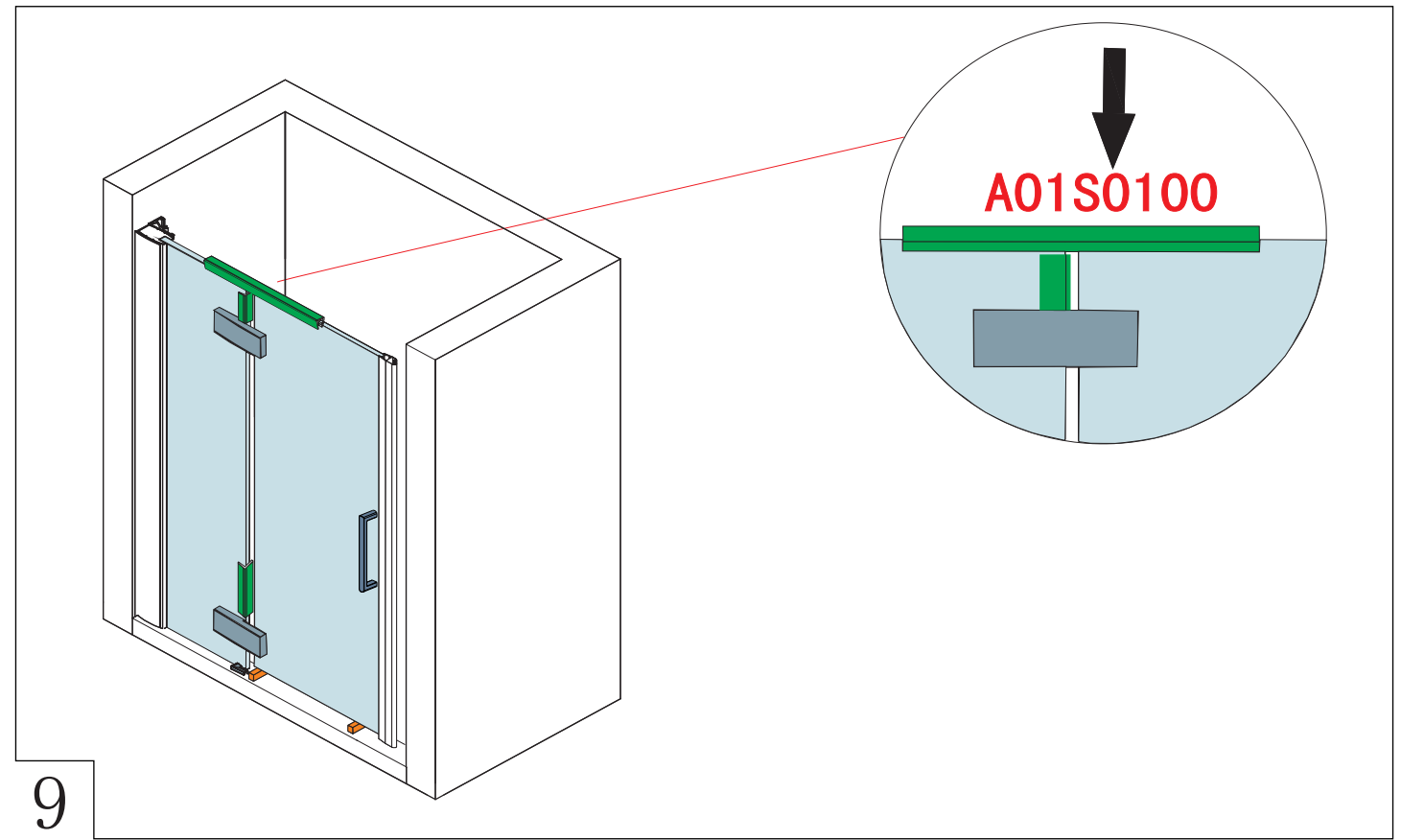
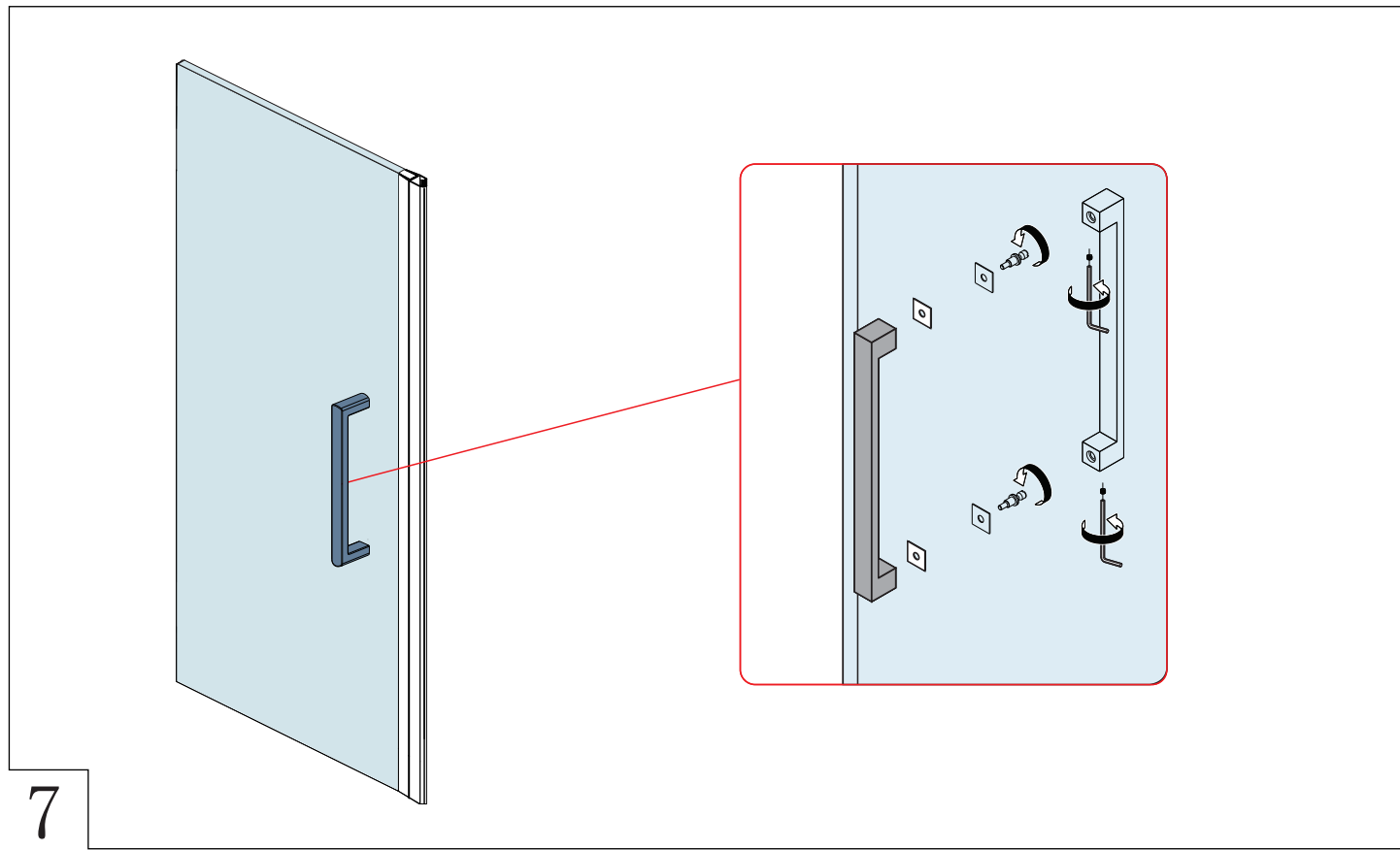

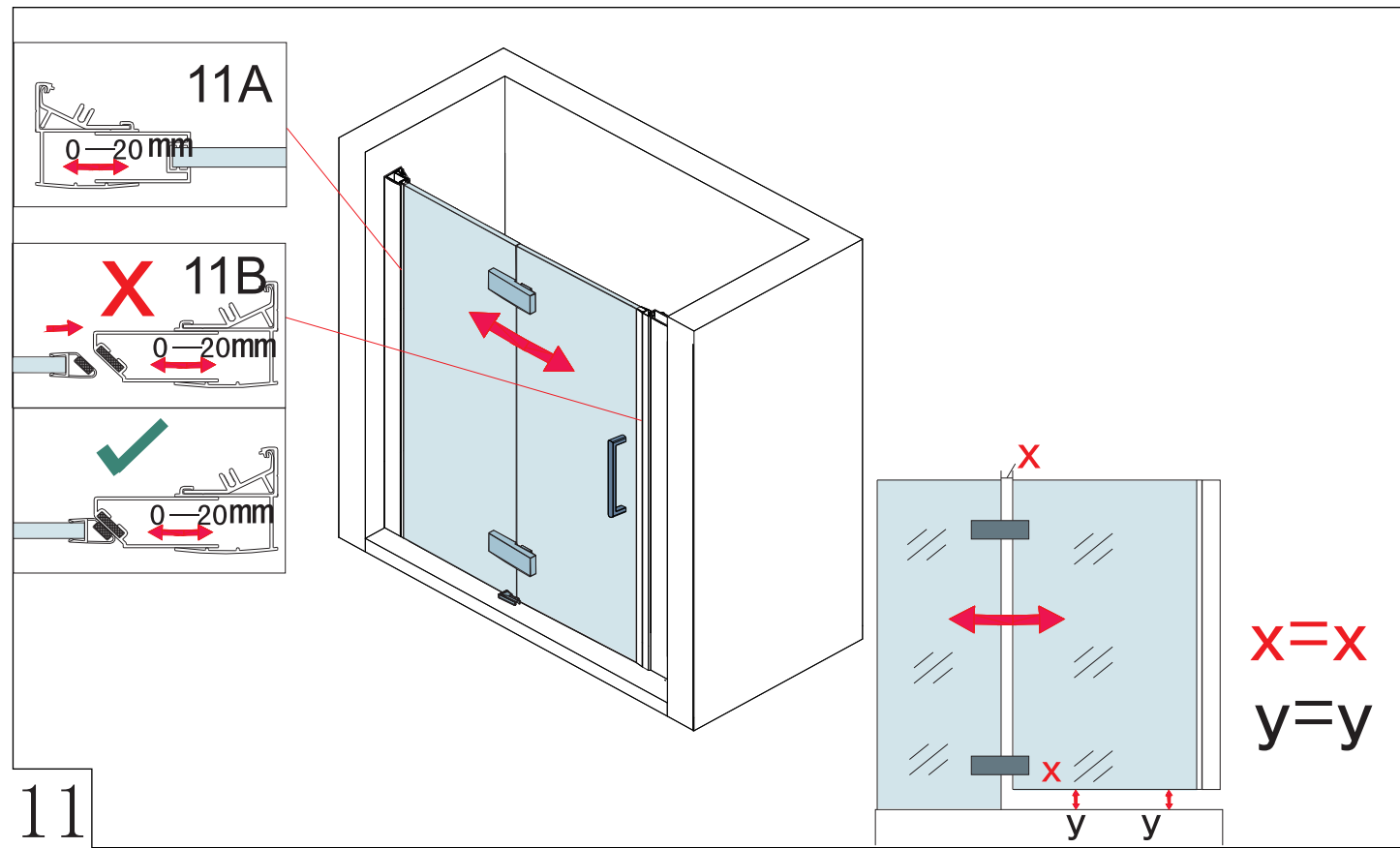

11

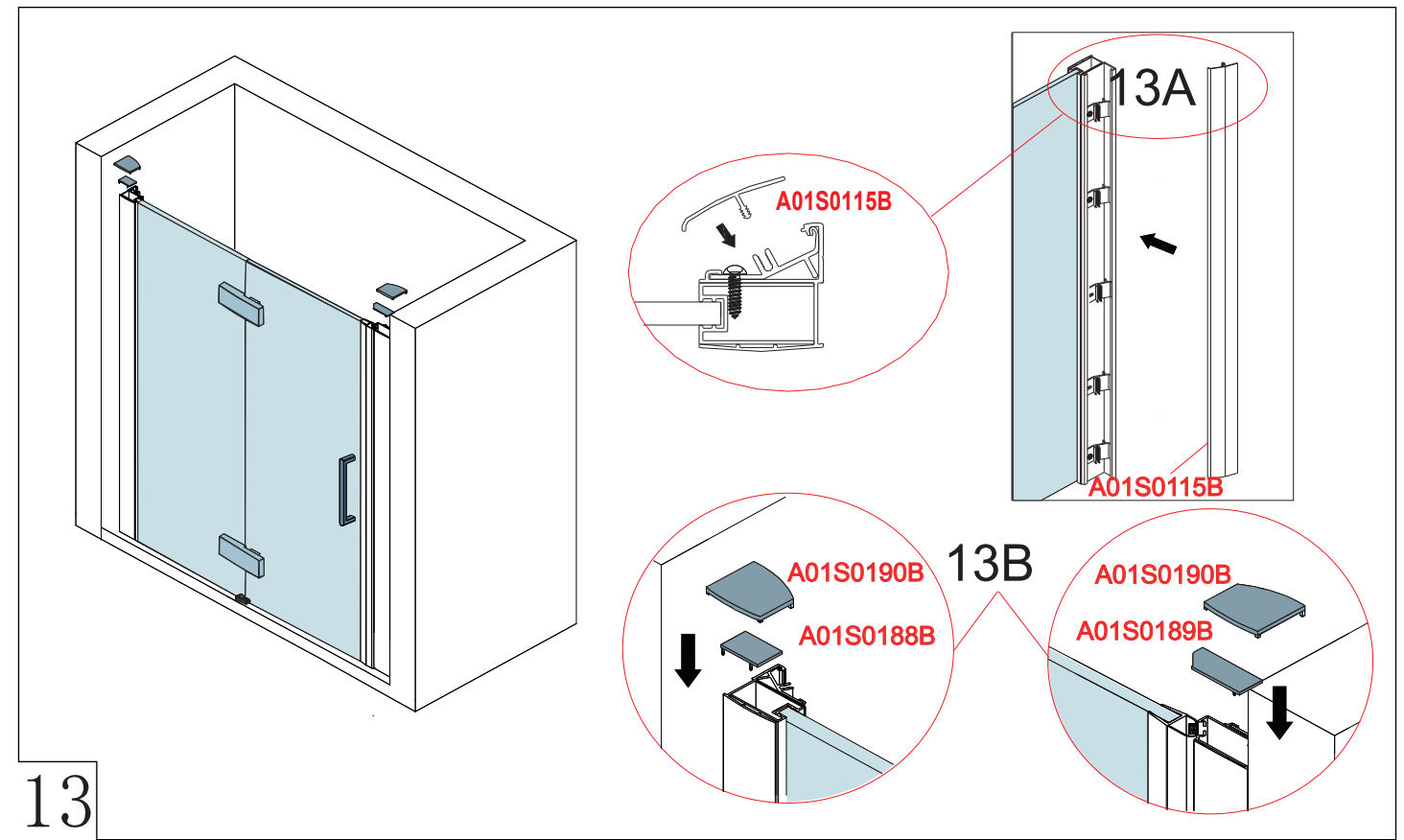

13

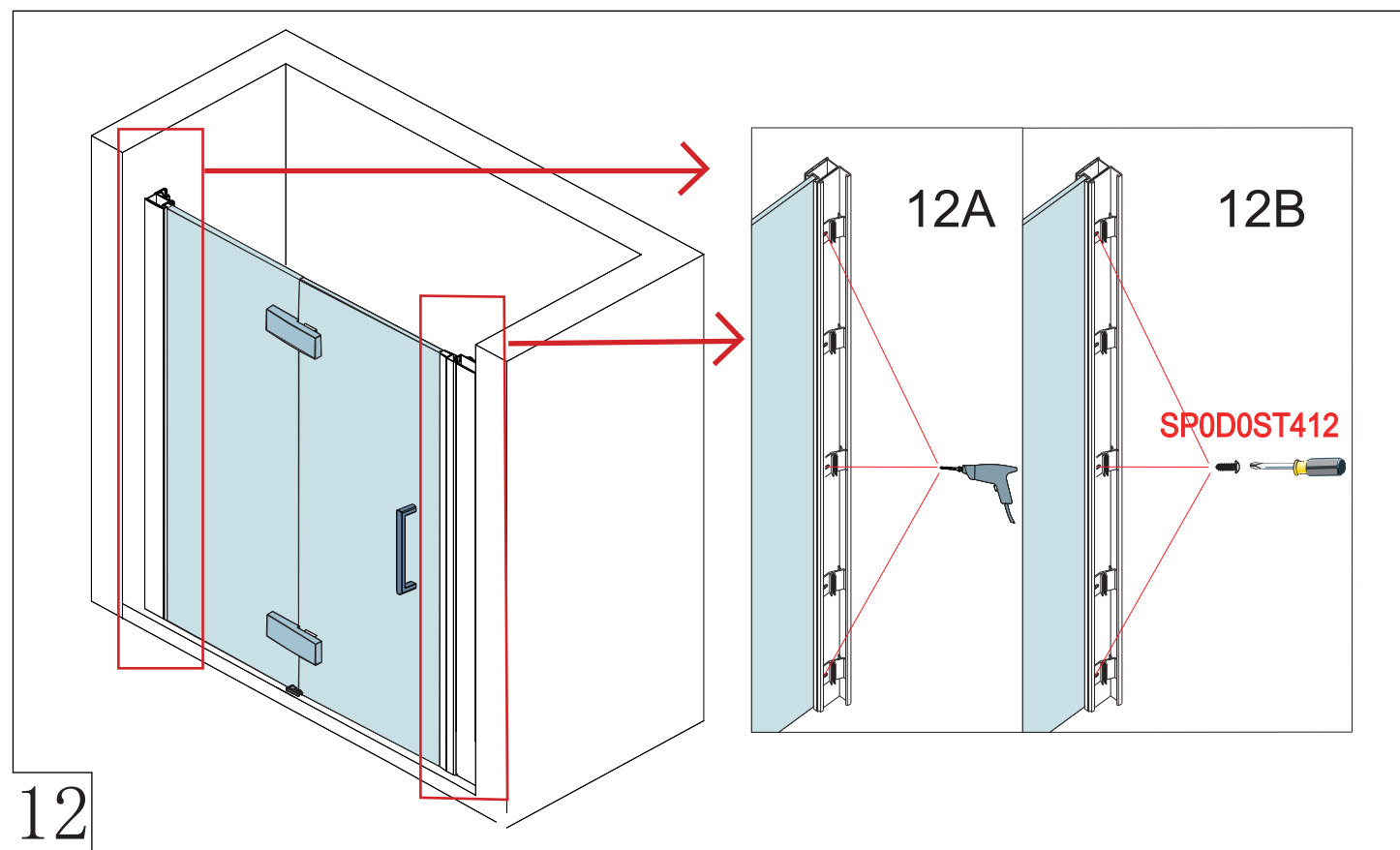

12

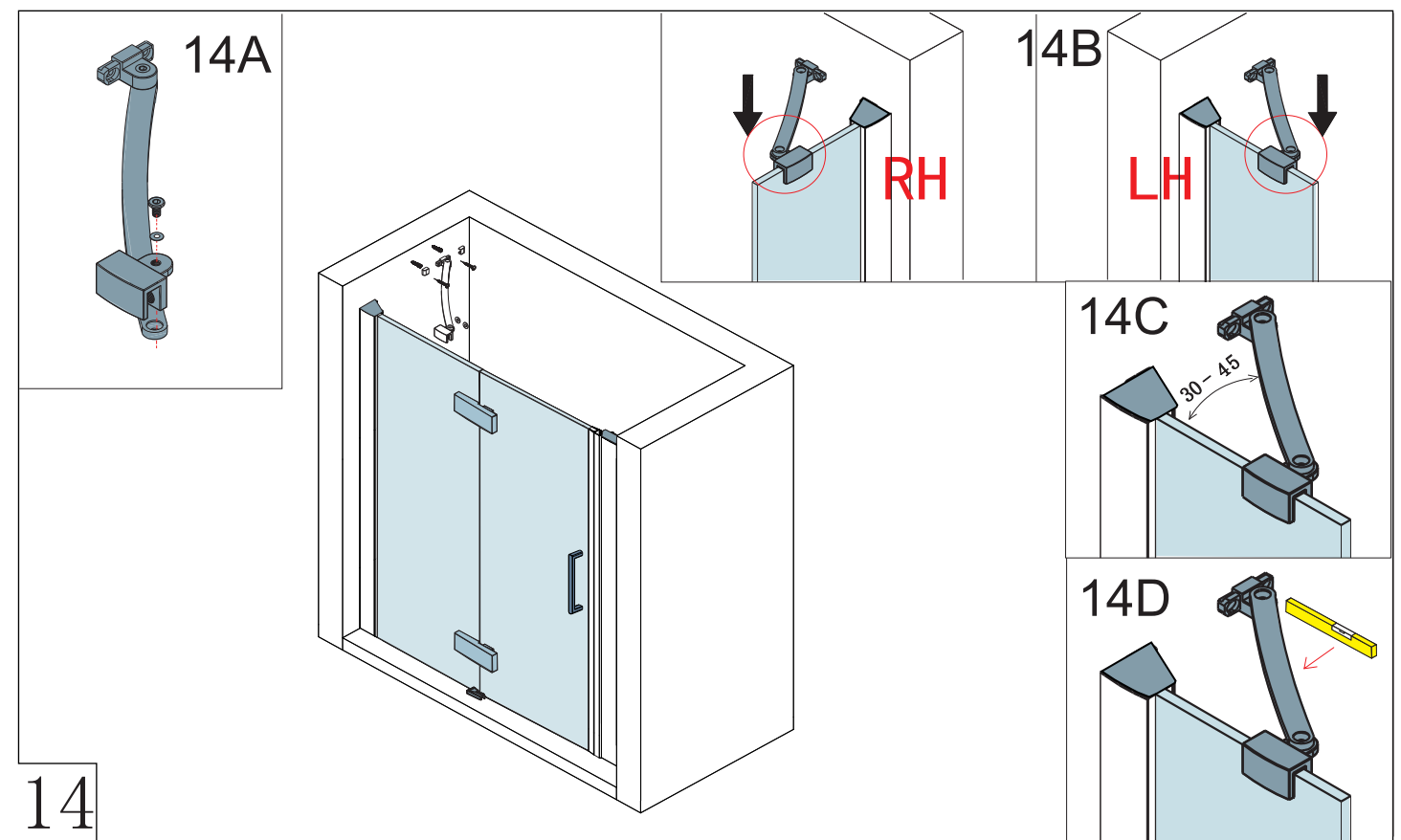

14

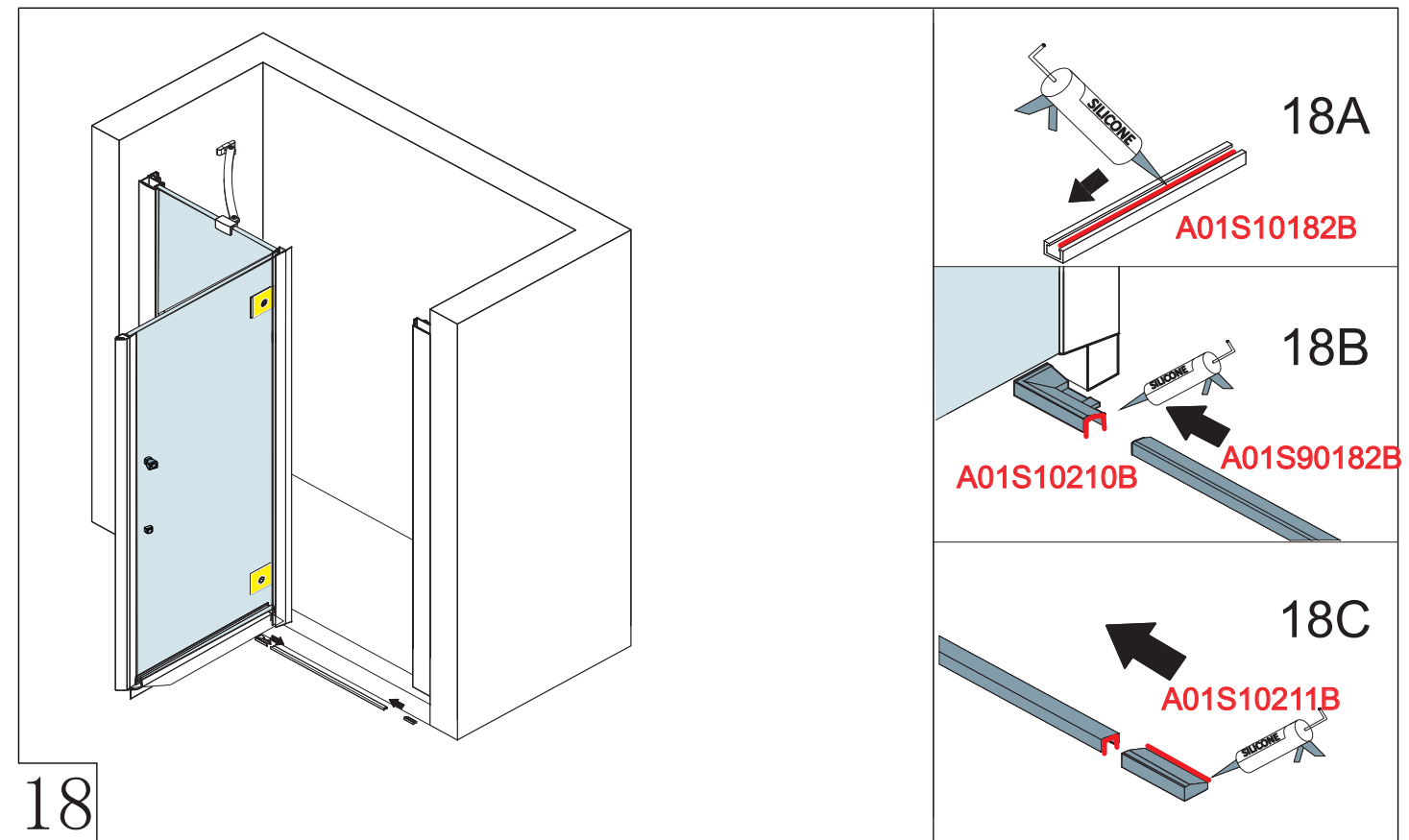
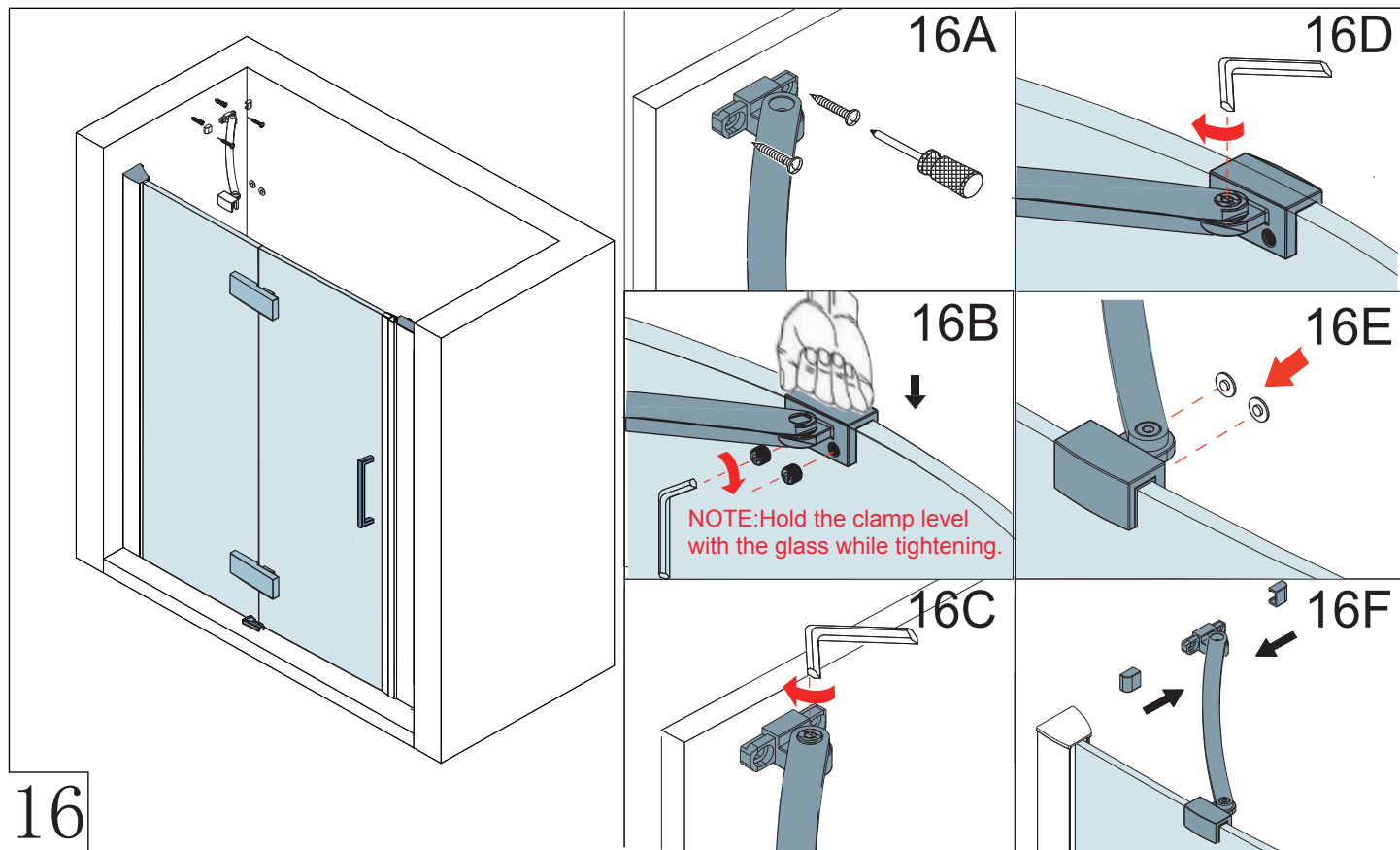
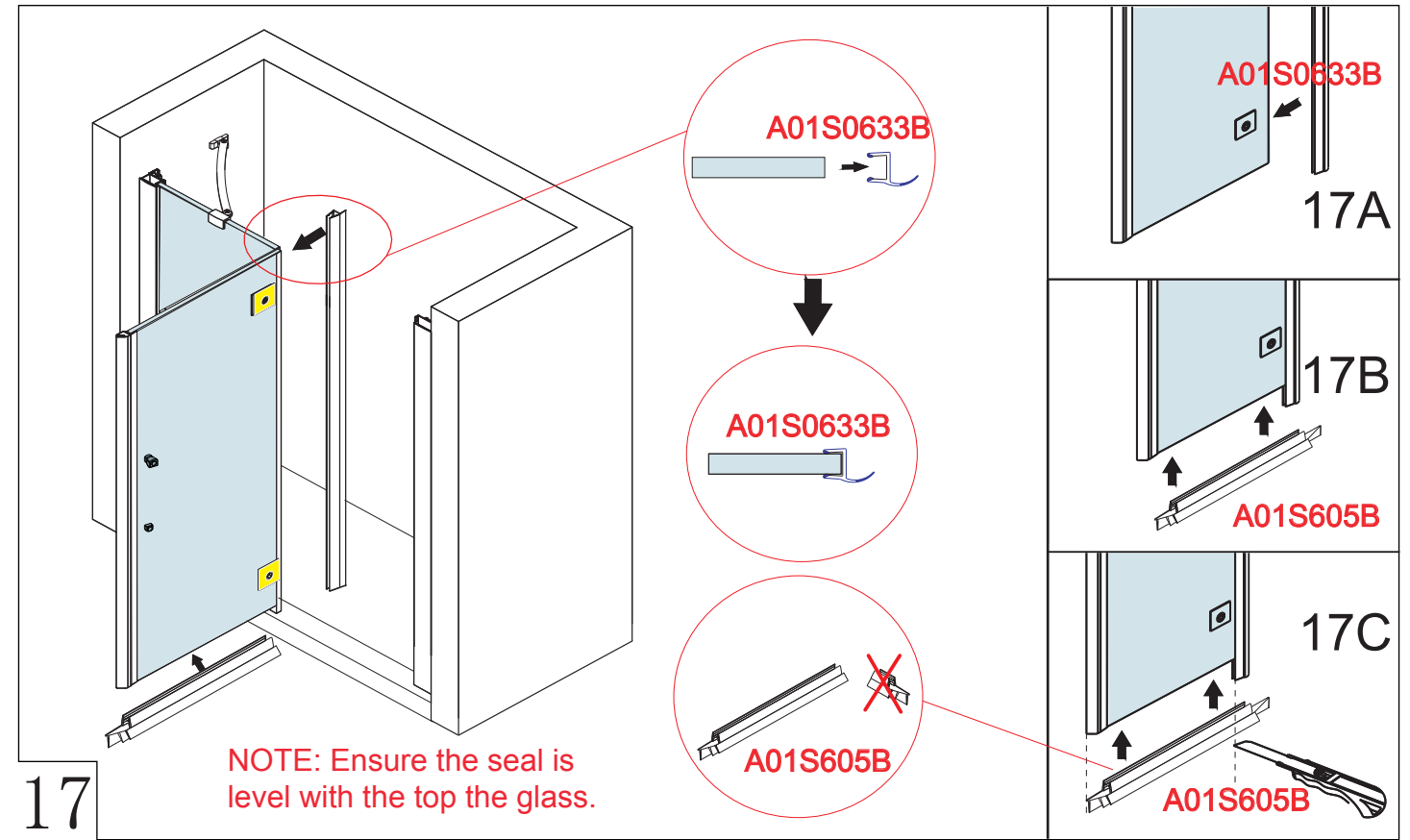
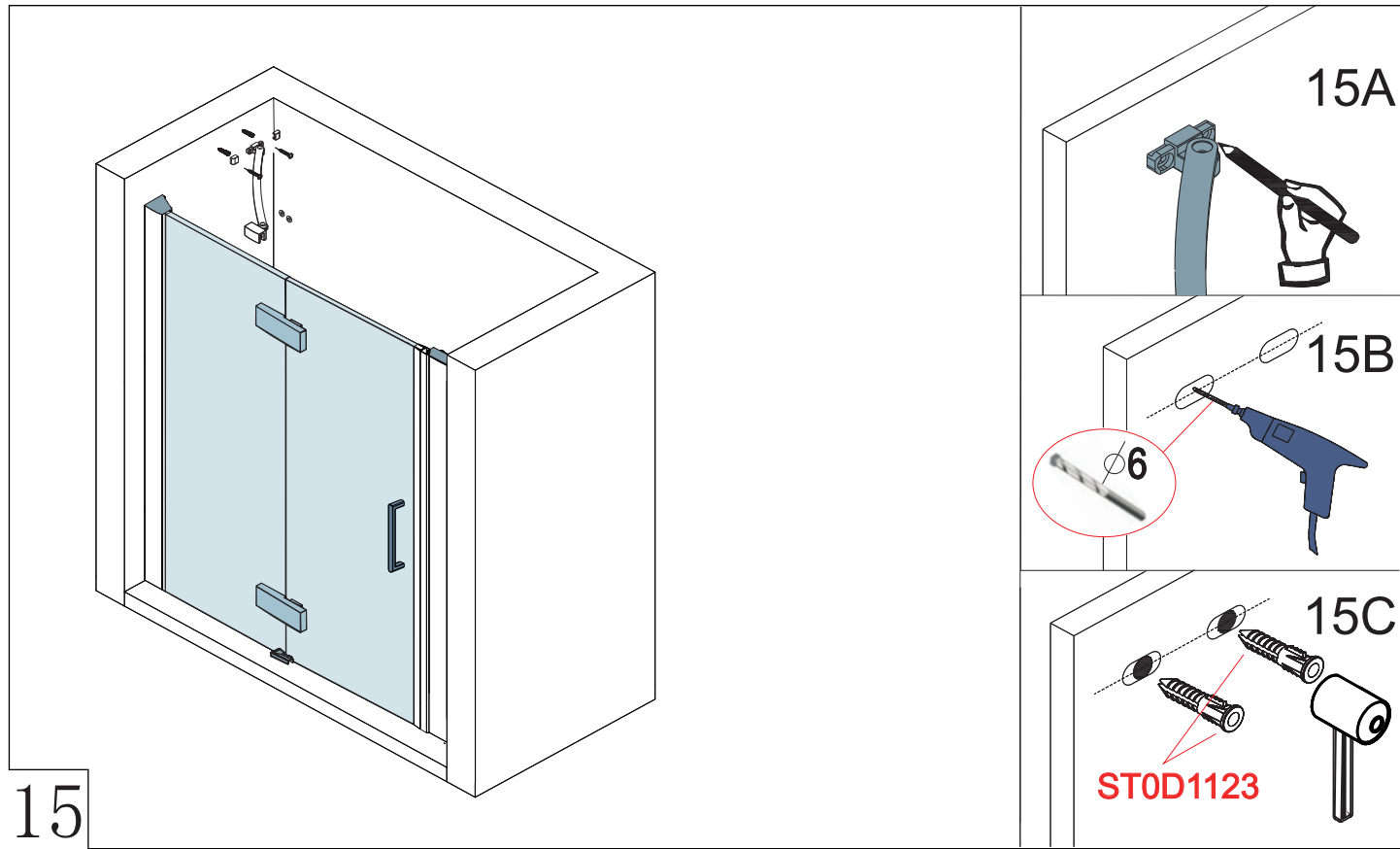

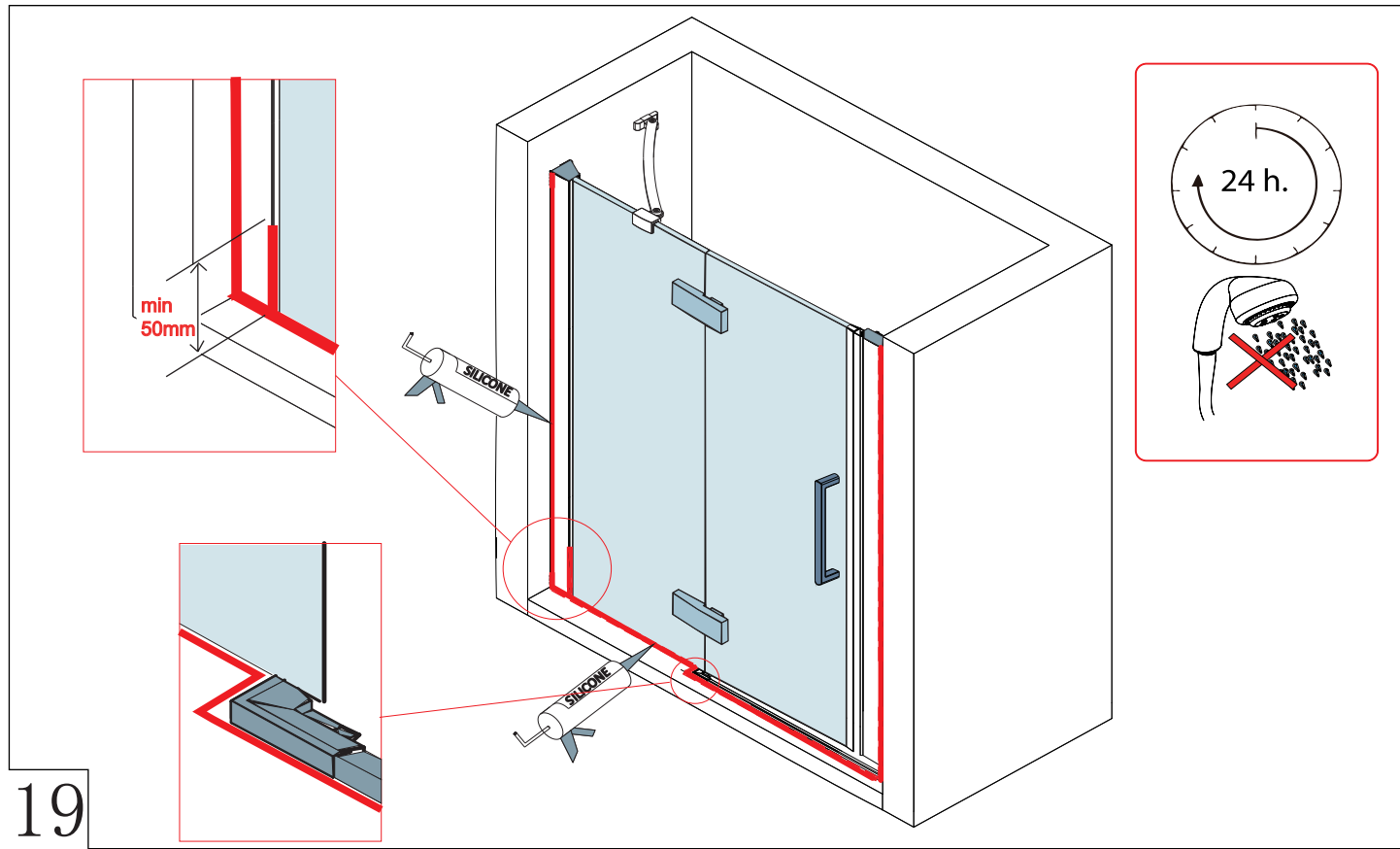

19

HINGE DOOR WITH SIDE PANEL

IMPORTANT

Thank you for choosing Merlyn. Please familiarise yourself with the fitting instructions before commencing fitting.

- 1 Check that you have the tools required
- 2 Check that the installation site is compatible
with size of door supplied
- 3 Check all the enclosure components
- 4 Check that the installation kit is complete

DO NOT attempt to install the product unless you can tick **ALL 4** boxes as satisfactory.
The wall plugs supplied with the installation kit are for use in solid walls. Hollow or 'stud - partition' walls will require alternative fixings. Please consult a hardware supplier for the correct type.
It may also be necessary to consult your tiling supplier about the correct method for drilling your tiles.

USE SAFETY EYEWEAR WHEN DRILLING

Any parts missing or damaged must be reported to your supplier within 5 days of purchase. Inspect shower enclosure before fitting. No claims will be accepted after product has been installed.

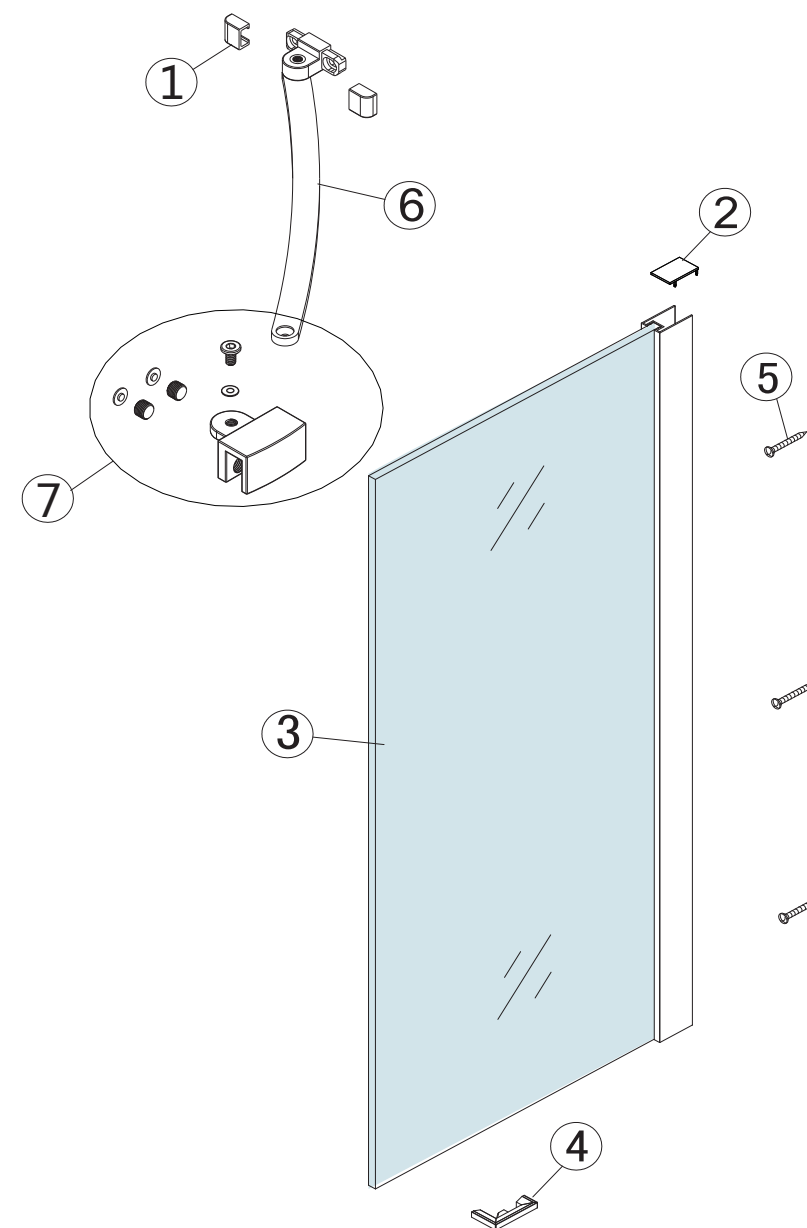

No.	Qty	Description	Part No.	No.	Qty	Description	Part No.
①	2	Bracing bar cover cap	A01S0619B	⑥	1	Bracing bar	B
②	1	Upright profile cap	A01S0188B	⑦	1	Bracing bar clamp	A01S0289B
③	1	Side panel	A				
④	1	Side panel footplate	A01S0212B				
⑤	3	Pan head screw 4 x 30	SP0D0ST430				

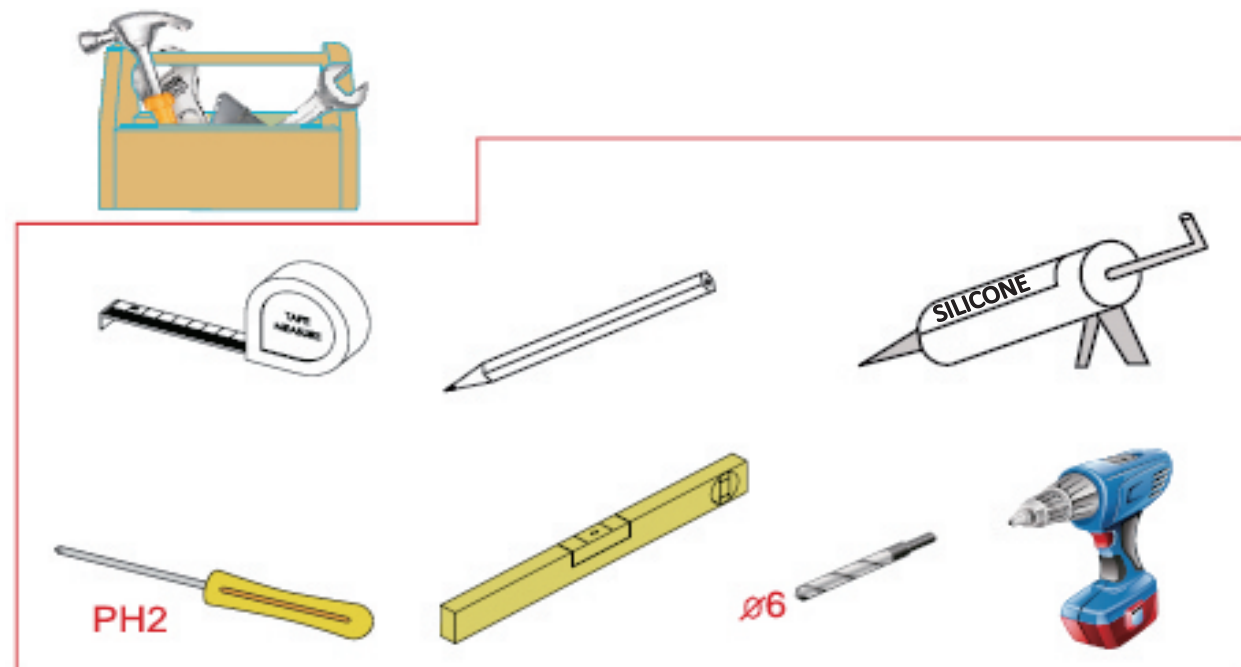
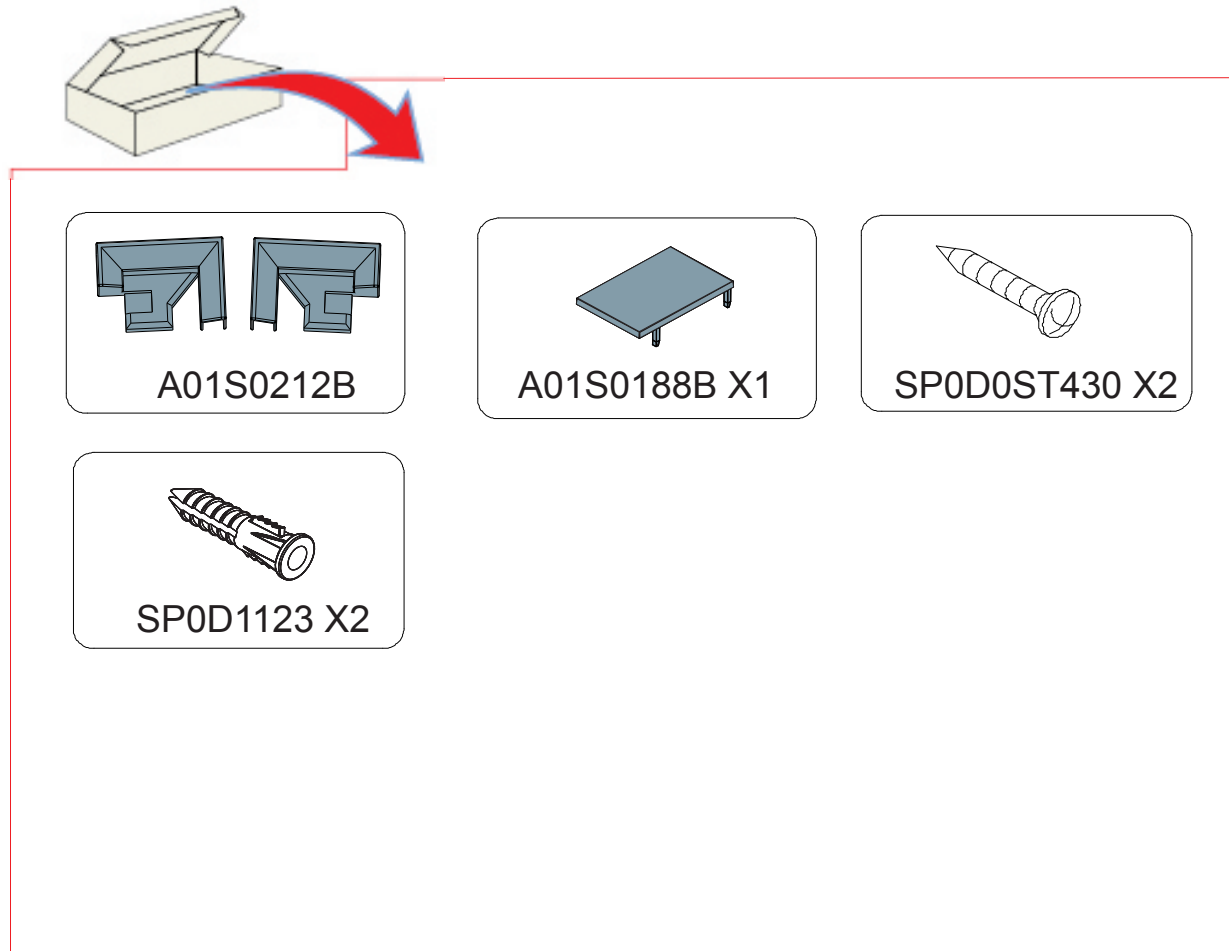

17.

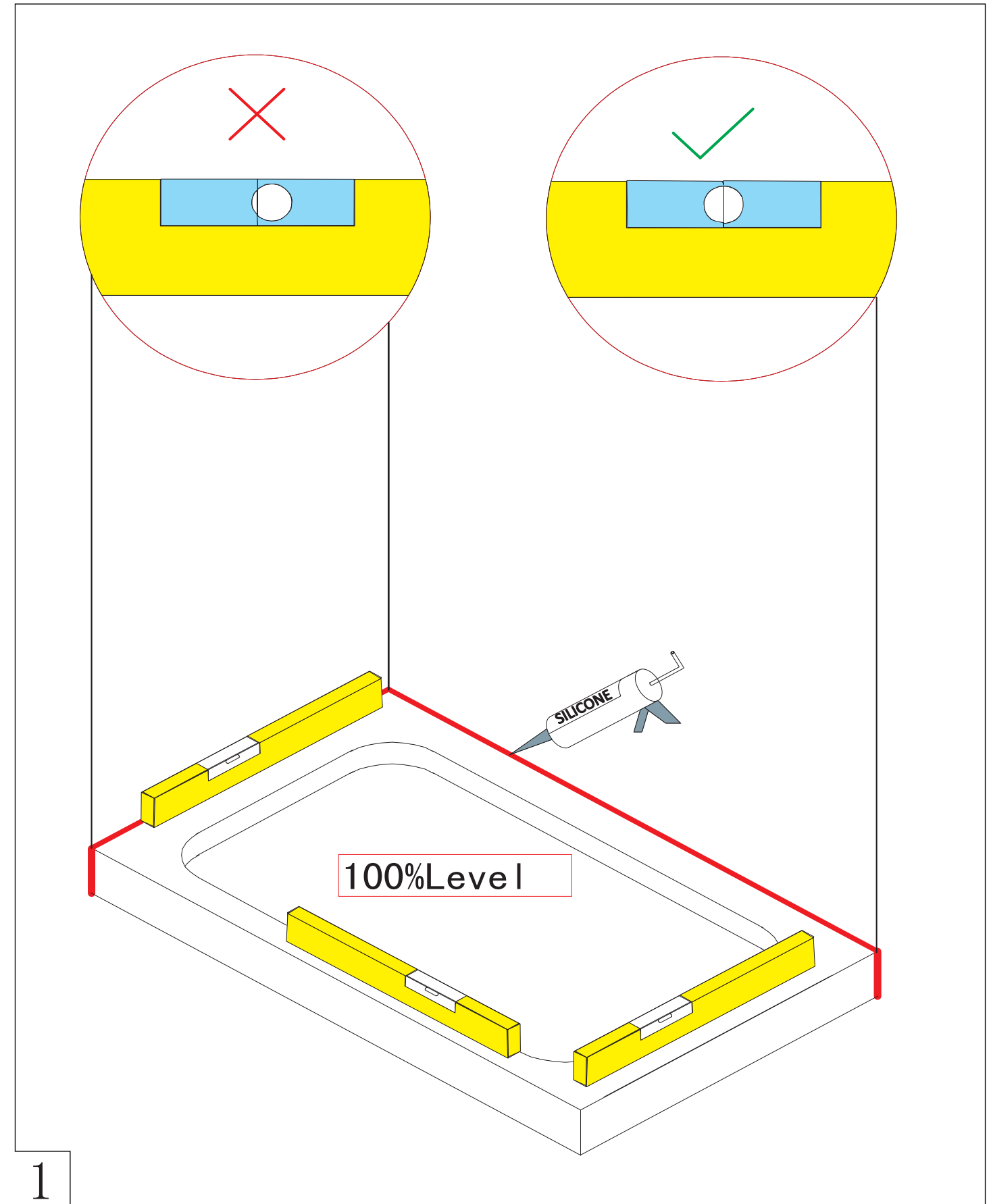

18.

