

Art. SYN110301

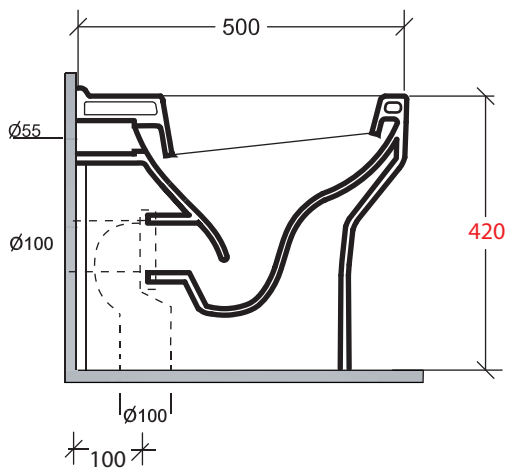

*CURVE TECNICHE PIPE CONNECTORS
Art.RASB
100 da 100/110
100 from 100/110

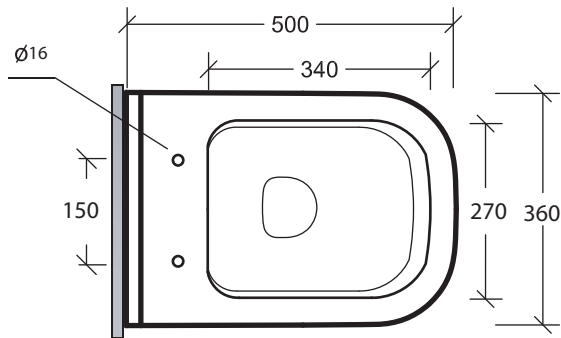
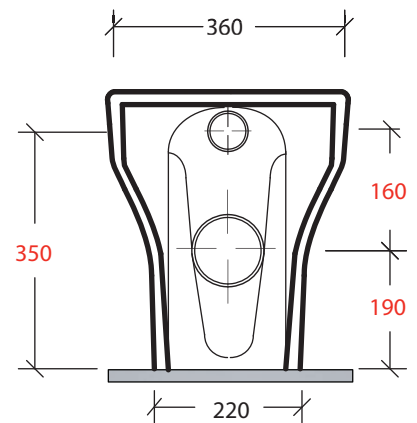

* Quota d'installazione consigliata
* Advised measure for installation

CARATTERISTICHE DEL PRODOTTO / PRODUCT FEATURES

- wc terra BTW Art. SYN110301
- BTW wc Art. SYN110301

MANUTENZIONE / MAINTENANCE

- pulire con acqua e sapone o altri prodotti adatti
- evitare prodotti abrasivi o aggressivi
- please clean with water and soap or other suitable products
- pleas avoid any aggressive or abrasive product

CONFEZIONE DEL PRODOTTO / PACKAGING PRODUCTS

- imballi in scatole di cartone 36x51x44
- imballo su bancale per pezzi multipli
- packaging in carton boxes 36x51x44
- packaging on pallets for multiple pieces

**PRODOTTO
PRODUCT**

wc terra/back to wall

**MATERIALE
MATERIAL**

witrous china

**TRATTAMENTO
TRETMENT**

smaltato/glazed

COLORE / COLOR

bianco,nero,bianco mat,nero m at
white,black,white mat,black mat

DESCRIZIONE / DESCRIPTION

wc serie synthesis - peso 23,5 Kg
back to wall synthesis - weight 23,5 Kg

CERTIFICAZIONI / CERTIFICATION

UNI EN .997 2012

FISSAGGI / HARDWARE

inclusi
included