

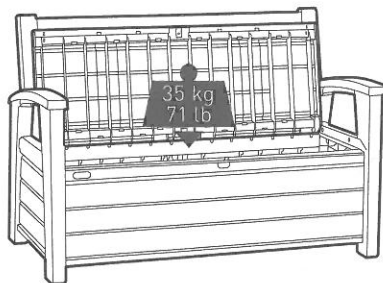

HUDSON 227L / 60 US GAL

EN ASSEMBLY INSTRUCTIONS FR INSTRUCTIONS DE MONTAGE GE MONTAGEANLEITUNG NL MONTAGEVOORSCHRIFT
ES INSTRUCCIONES DE MONTAJE IT ISTRUZIONI DI MONTAGGIO PT INSTRUÇÕES DE MONTAGEM

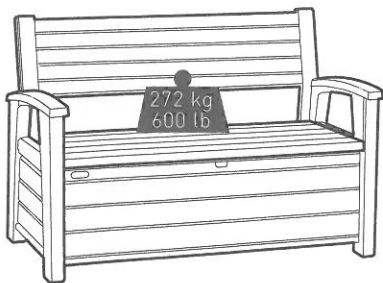
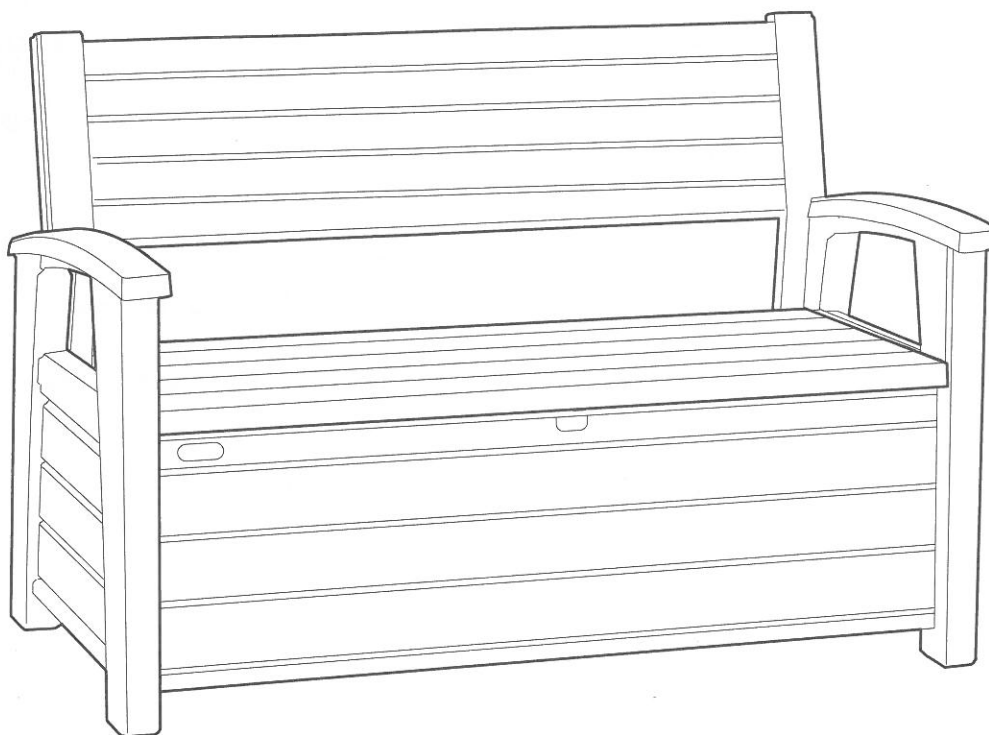

A-2334-0 584357

- EN **IMPORTANT:** Please contact Customer Service if you have any problems or discover any missing parts.
- FR **IMPORTANT:** Veuillez contacter notre Service Clientèle pour tout problème ou pièce manquante.
- GE **WICHTIG:** Bitte wenden Sie sich an unseren Kundenservice, falls Sie irgendwelche Probleme haben oder feststellen, daß Teile fehlen.
- ES **IMPORTANTE:** Sírvase contactar con nuestro Servicio al Cliente por cualquier problema, o pieza que pudiera faltar.
- IT **IMPORTANTE:** Si prega di contattare il Servizio Clienti per eventuali necessità.
- NL **BELANGRIJK:** Neemt u in geval van problemen of missende onderdelen a.u.b. contact op met de klantenservice.
- PT **IMPORTANTE:** favor entrar em contato com o Serviço ao Cliente se houver problemas ou se faltar peças.



USA & Canada:
1-(888)-374-4262
UK: Tel: 0121-5060008
Fax: 0121-4220808
Other European Countries:
Tel: +31-1612-28301
Fax: +31-1612-28322

WWW.KETER.COM



Comfortably seats two adults | Siège confortablement deux adultes | Bietet bequemen Sitzplatz für 2 Erwachsene | Cómodo asiento para dos adultos | Biedt comfortabele zitplaats aan twee volwassenen | Offre due comodi posti a sedere per adulti | Podem sentar-se confortavelmente dois adultos



All weather design | Conçu pour résister aux différentes conditions climatiques | Diseño apto para todo tipo de climas | Wetterfest | Ontworpen voor alle weersomstandigheden | Design per tutte le stagioni | Design para todos os climas



Lockable (lock not included) | Verrouillable (verrou non inclus) | Abschließbar (Vorhängeschloß nicht im Lieferumfang) | Apto para candado (que no se incluye) | Afsluitbaar (slot niet inbegrepen) | Richiudibile (lucchetto non incluso) | Pode ser Trancado (fecho não incluído)

CAUTION | AVERTISSEMENT | WICHTIG | ADVERTENCIA WAARSCHUWING | ATTENZIONE | ATENÇÃO













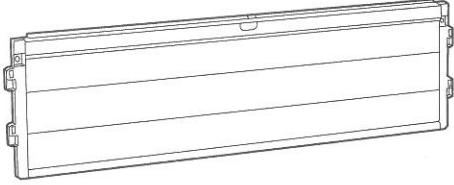
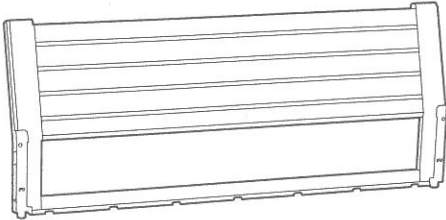
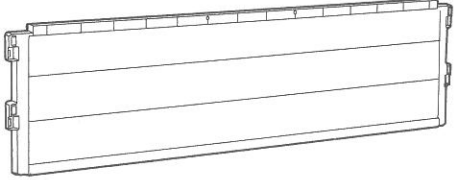
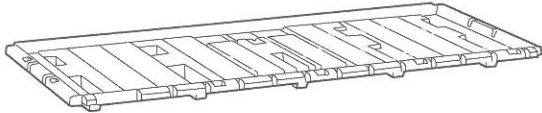
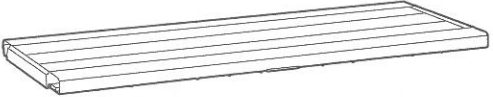
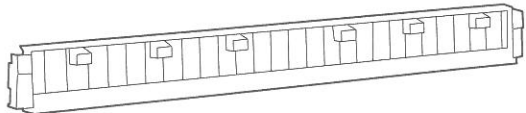
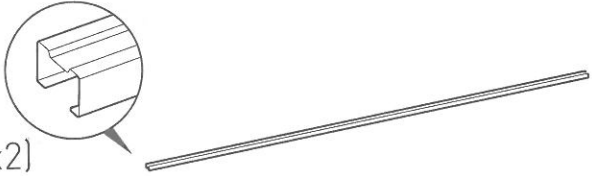
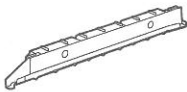
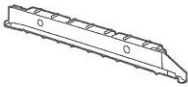



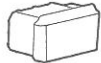

- EN Some parts have metal edges. Please be careful when handling components. Always wear work gloves
- FR Certaines pièces ont des bords en métal. Soyez prudent en les manipulant. Portez toujours des gants de travail.
- GE Manche Teile haben Stahlkanten, bitte seien Sie vorsichtig beim Umgang mit diesen. Tragen Sie bei der Montage des Gartenschuppens oder Wartungsarbeiten stets Arbeitshandschuhe,
- ES Algunas partes incluyen bordes metálicos. Tenga cuidado al manejar estos componentes. Use siempre guantes de trabajo.
- NL Sommige onderdelen hebben stalen randen. Wees voorzichtig met het omgaan met deze onderdelen. Draag altijd werkhandschoenen,
- IT Alcune parti presentano bordi in acciaio. Fare attenzione nel maneggiare i componenti. Indossare sempre guanti da lavoro,
- PT Algumas peças têm extremidades de aço. Tenha cuidado ao manusear este componentes. Utilize sempre luvas e óculos de protecção



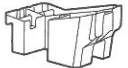



- EN Retain for future reference. Read carefully | For domestic use.
- FR À conserver pour référence ultérieure. Lire soigneusement | Pour usage domestique.
- GE Wichtig, für spätere bezugnahme aufbewahren: sorgfältig lesen | Für den privatgebrauch.
- ES Guardar para referencia futura. Leer atentamente | Para uso doméstico.
- IT Conservare per riferimenti futuri. Leggere attentamente | Per uso domestico.
- NL Bewaar voor toekomstige raadpleging. Lees nauwkeurig | Voor huishoudelijk gebruik.
- PT Guardar para referência futura. Ler cuidadosamente | Para utilização doméstica.



EN ASSEMBLY PARTS FR PIÈCES À ASSEMBLER DE MONTAGETEILE NL MONTAGESTUKKEN ES PIEZAS DE ENSAMBLE
IT PARTI DA MONTARE PT PEÇAS DE MONTAGE

EN Please check all parts and components to ensure that there are no damages or missing items BEFORE starting the construction of the product FR Assurez-vous que les parties et les éléments ne sont pas endommagés et qu'aucun ne manque AVANT de commencer le montage de ce produit DE Bitte überprüfen Sie alle Einzelteile und jegliches Zubehör, um sicherzugehen, dass keine Teile beschädigt sind oder fehlen, BEVOR Sie mit der Montage des Produkts beginnen NL Controleer alle onderdelen en componenten om te verzekeren dat er geen schade of ontbrekende items zijn VOOR dat u het product in elkaar begint te zetten ES ANTES de comenzar la construcción del producto, compruebe todas las partes y componentes para asegurarse de que no hay daños y de que no falta ningún elemento IT Si prega di controllare tutti i pezzi ed i componenti per accertarsi che non ci siano danni o elementi mancanti PRIMA di montare il prodotto PT Por favor, verifique todas as peças e componentes para garantir que não há danos ou itens incompletos ANTES de iniciar a construção do produto

					
WSL (x1)	WSR (x1)	WPF (x1)			
					
WBR (x1)		WBP (x1)			
					
EP (x1)		WLP (x1)			
					
AC (x1)		MP (x2)			
					
1WL (x1)	1WR (x1)	WFS (x1)	WBS (x1)		
					
CFL (x1)	CFR (x1)	AL (x1)	AR (x1)		
					
CBL (x1)	CBR (x1)	LN (x1)	RN (x1)		
					
LA (x2)	LB (x2)	CP (x2)	WL1 (x1)	WL2 (x1)	S (x27)

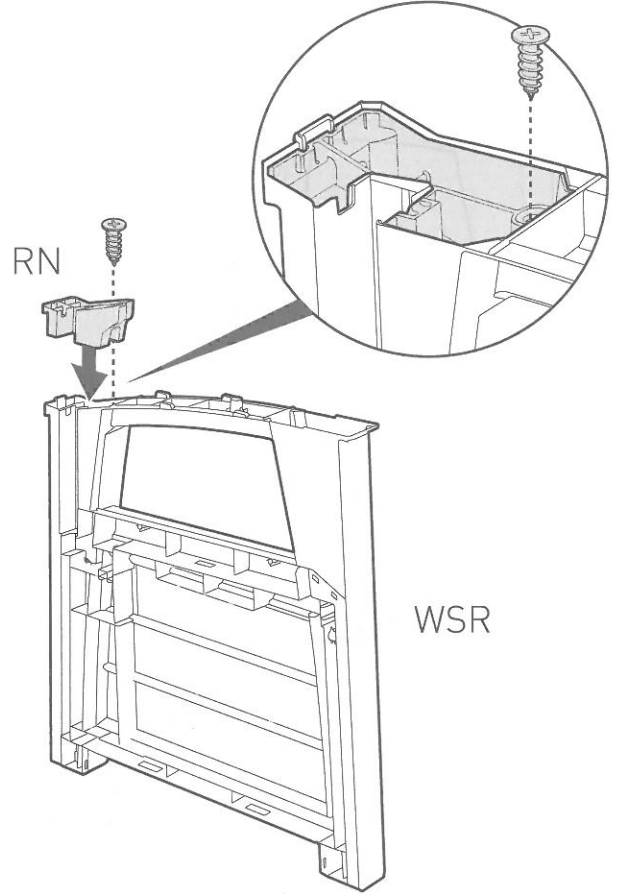
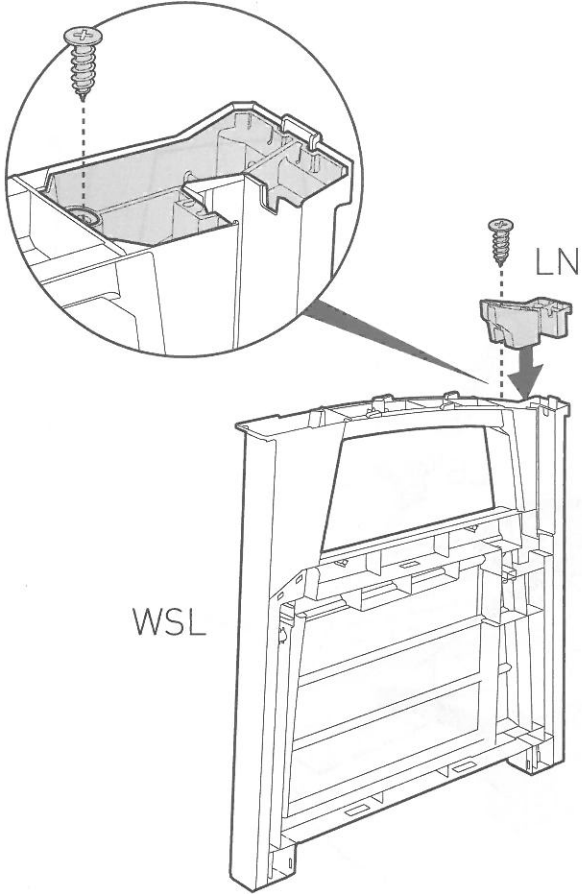
- 1 |  WSL (x1) |  WSR (x1) |  LN (x1) |  RN (x1) |  S (x2)

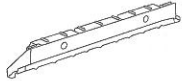
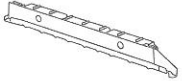

- 2 |  1WL (x1) |  1WR (x1) |  S (x4)

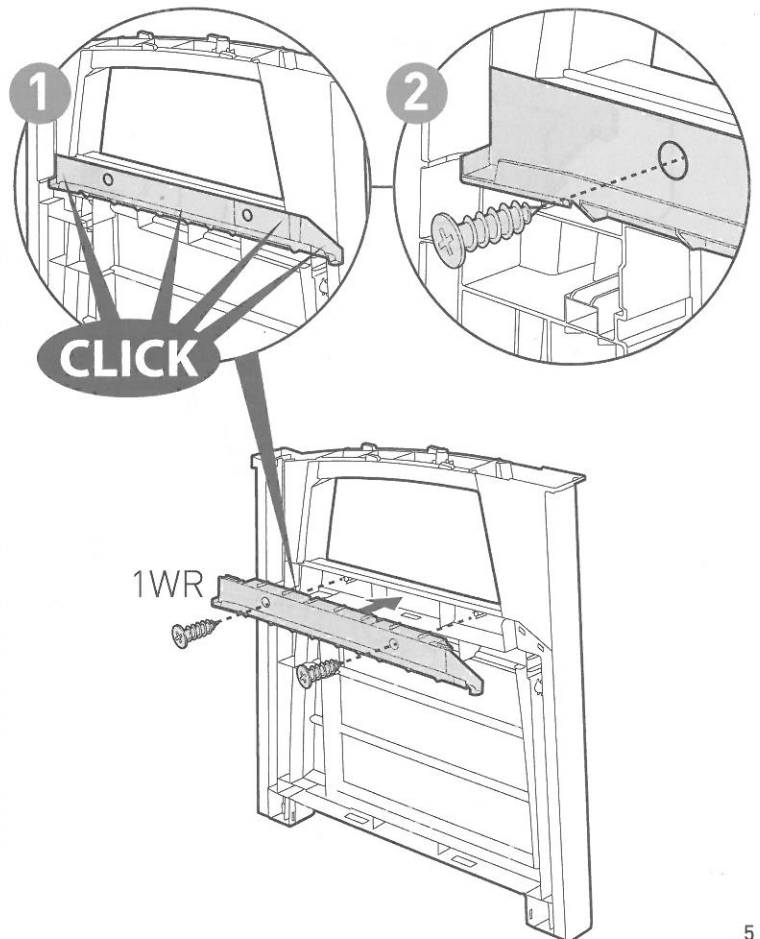
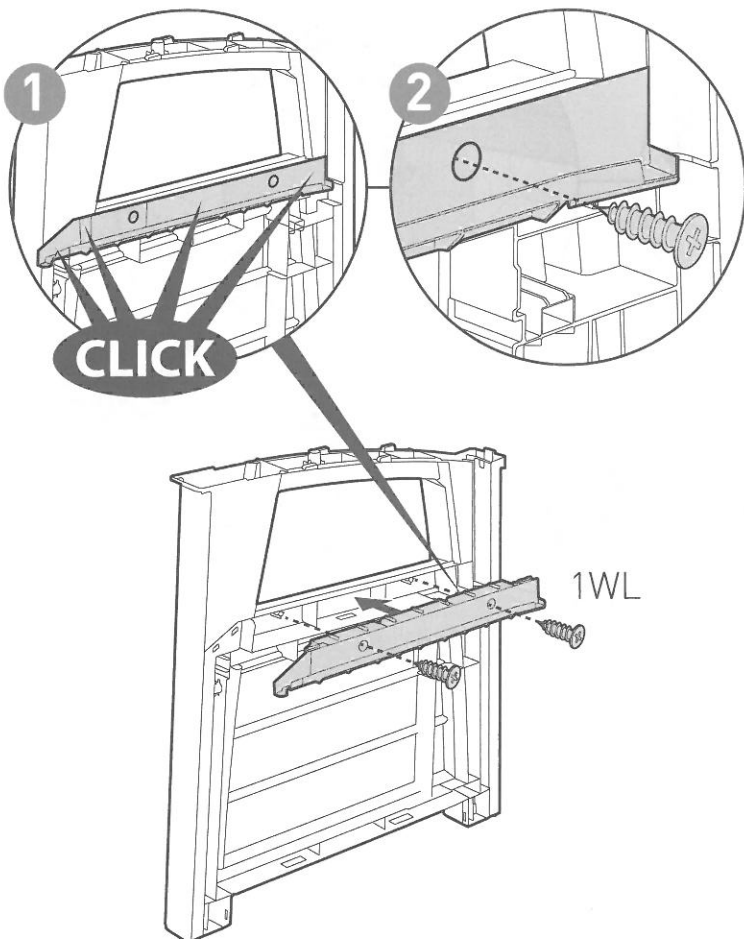

3



LA (x2)



LB (x2)

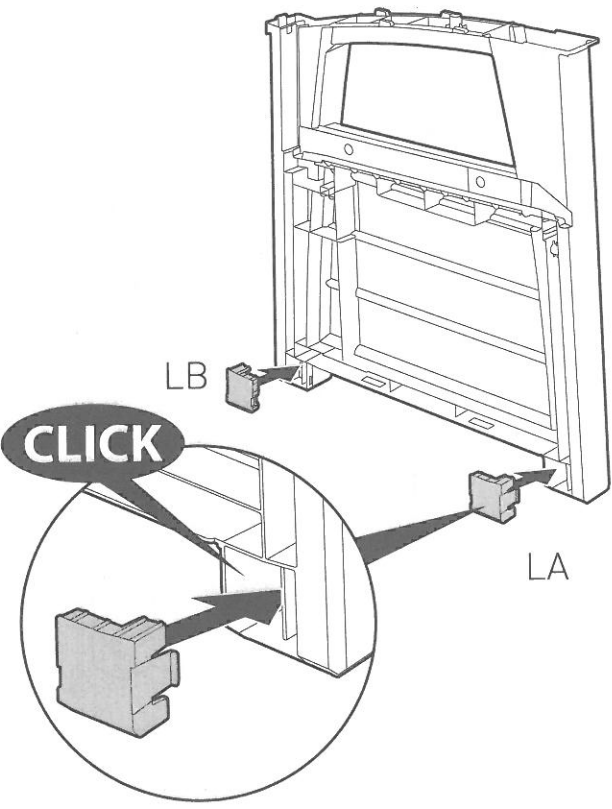
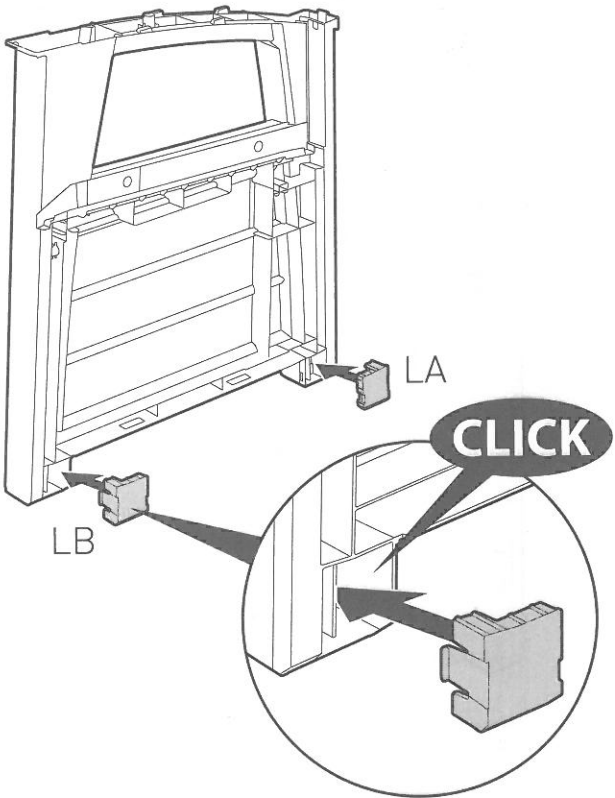

4



AC (x1)



MP (x1)

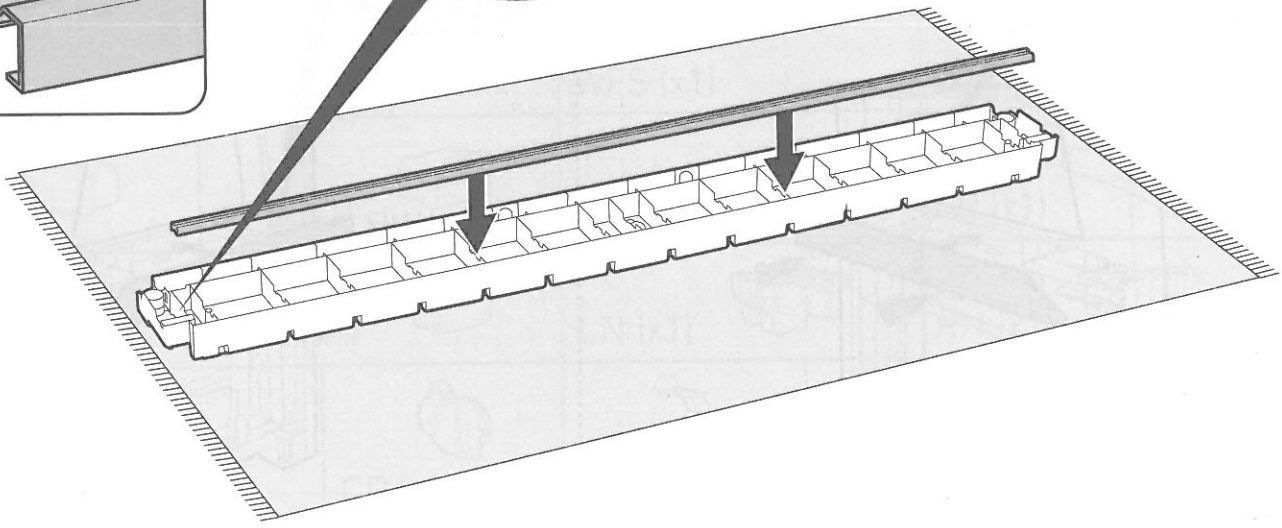
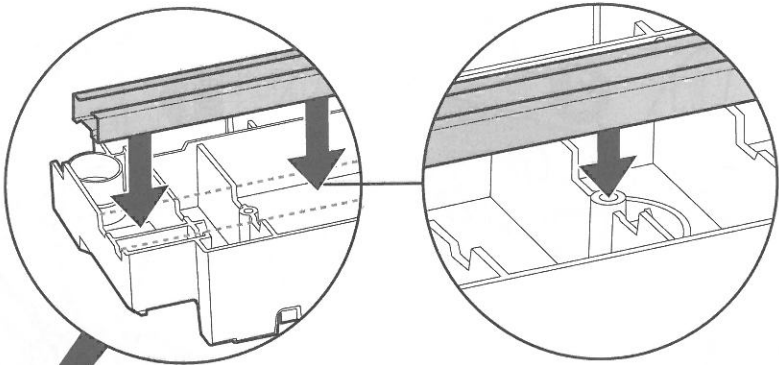
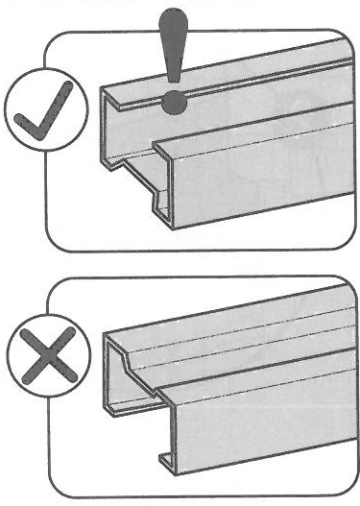

5



S (x3)

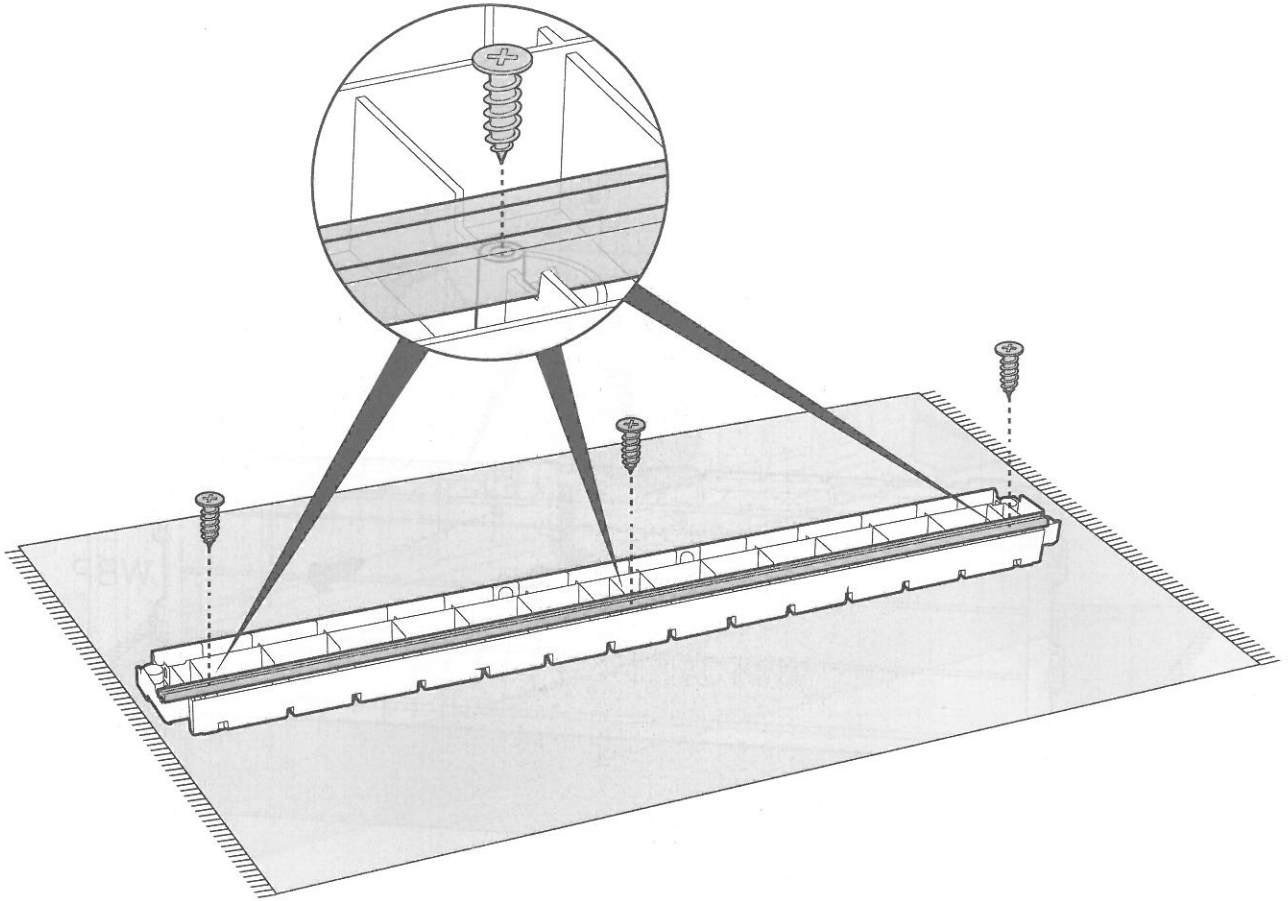

6

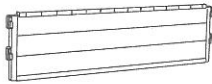

WBP (x1)



AC (x1)

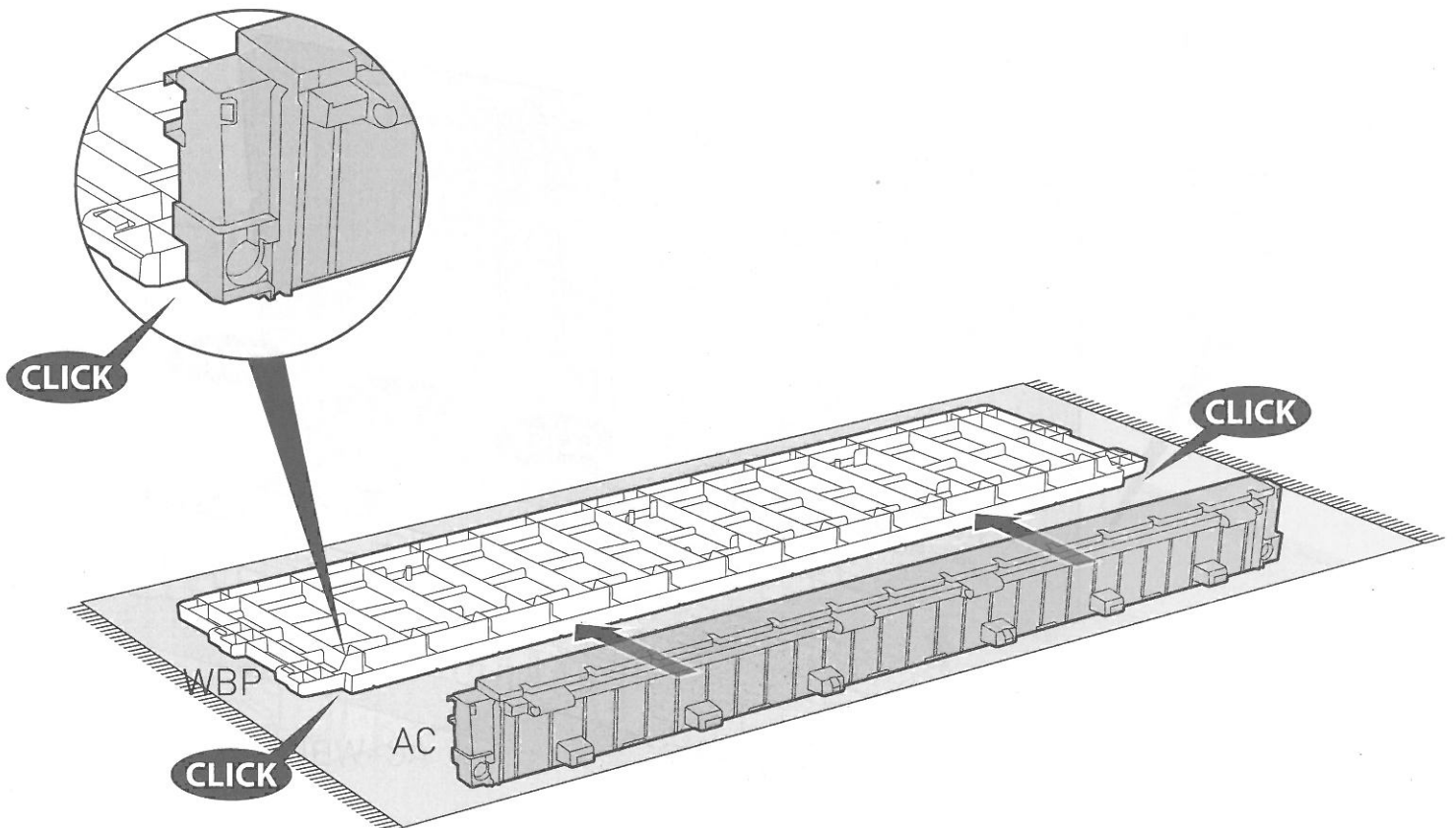

7



S (x2)

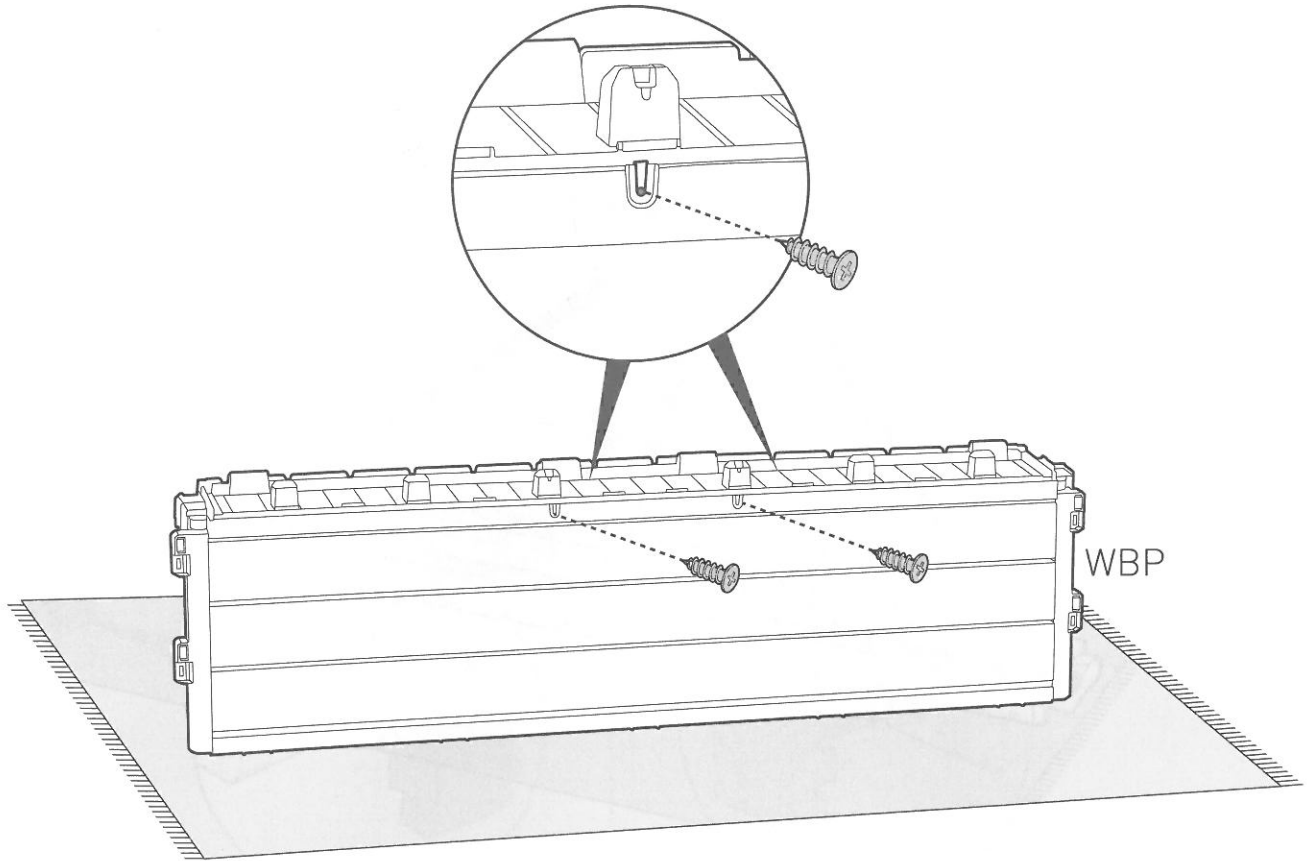

8

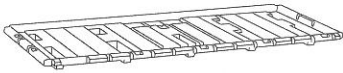

EP (x1)

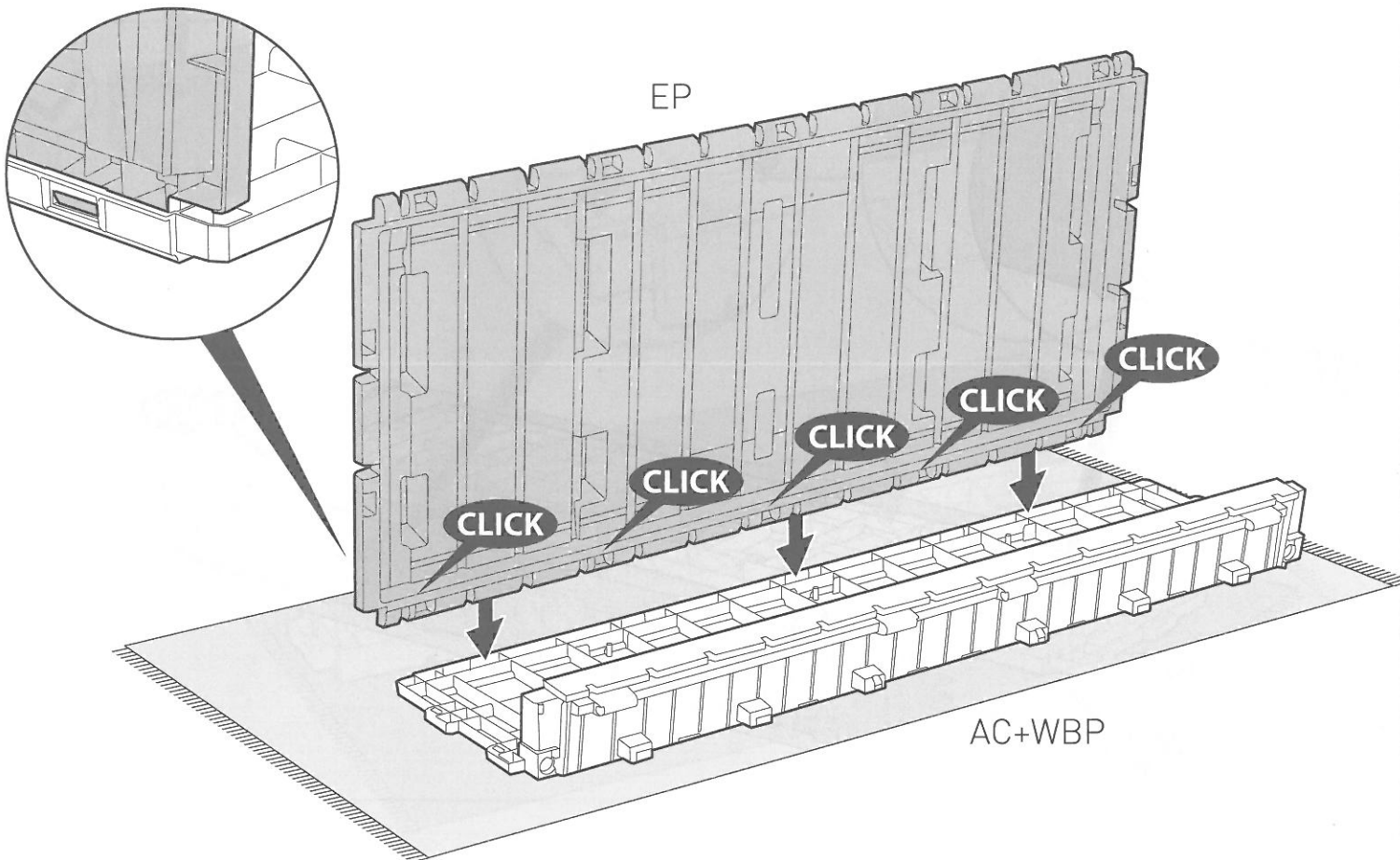

9



WBS (x1)

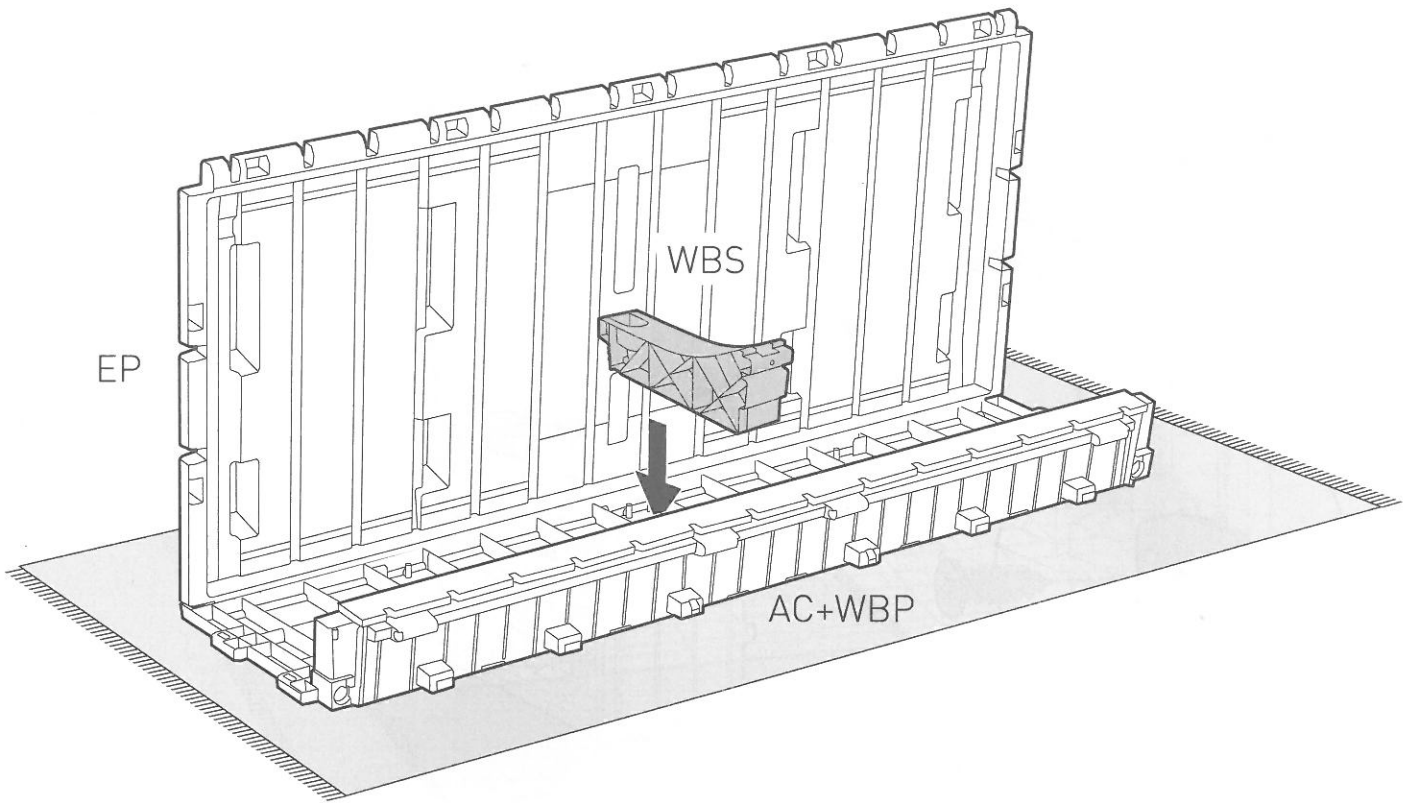

10



S (x1)

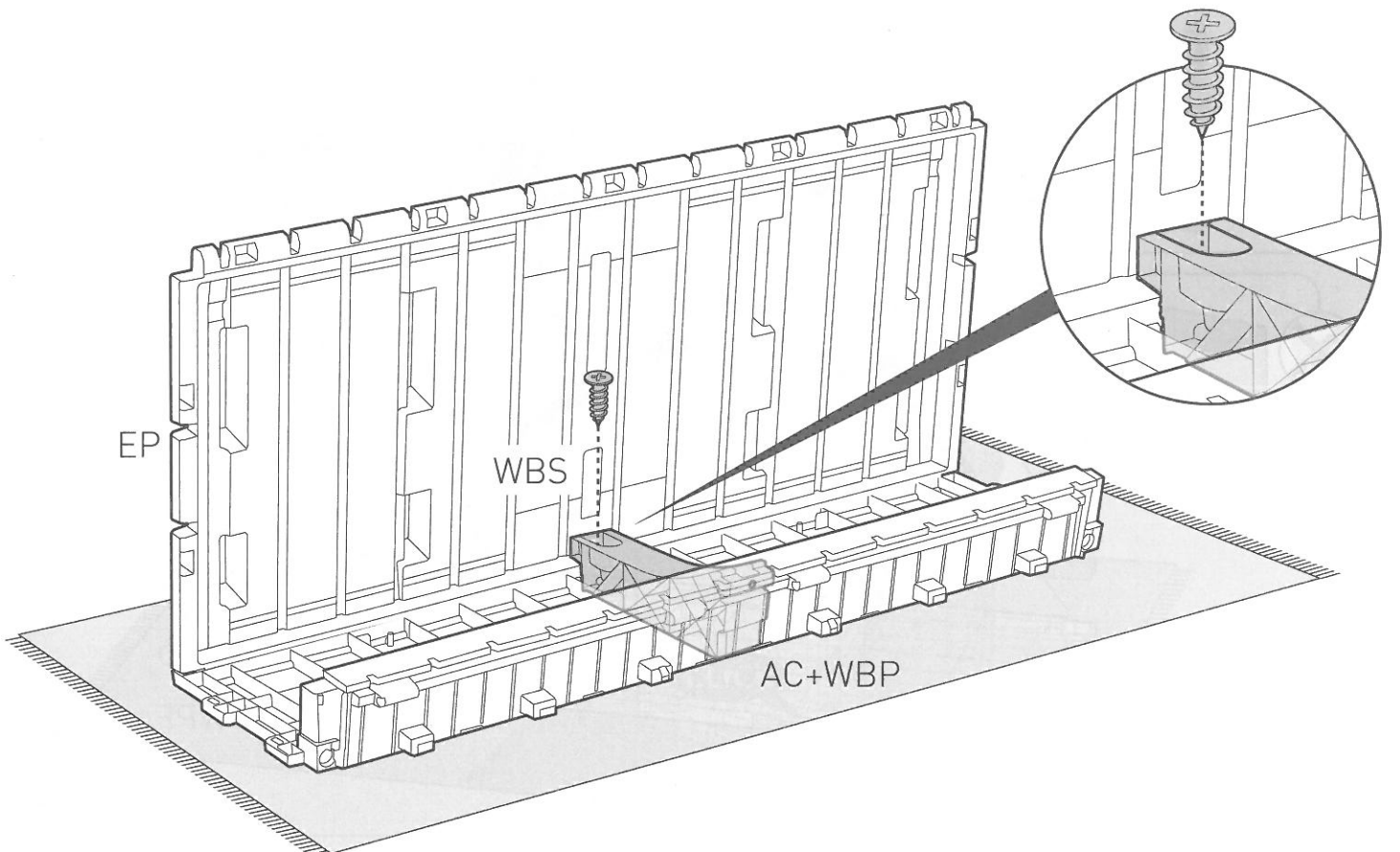

11



WFS (x1)



S (x1)

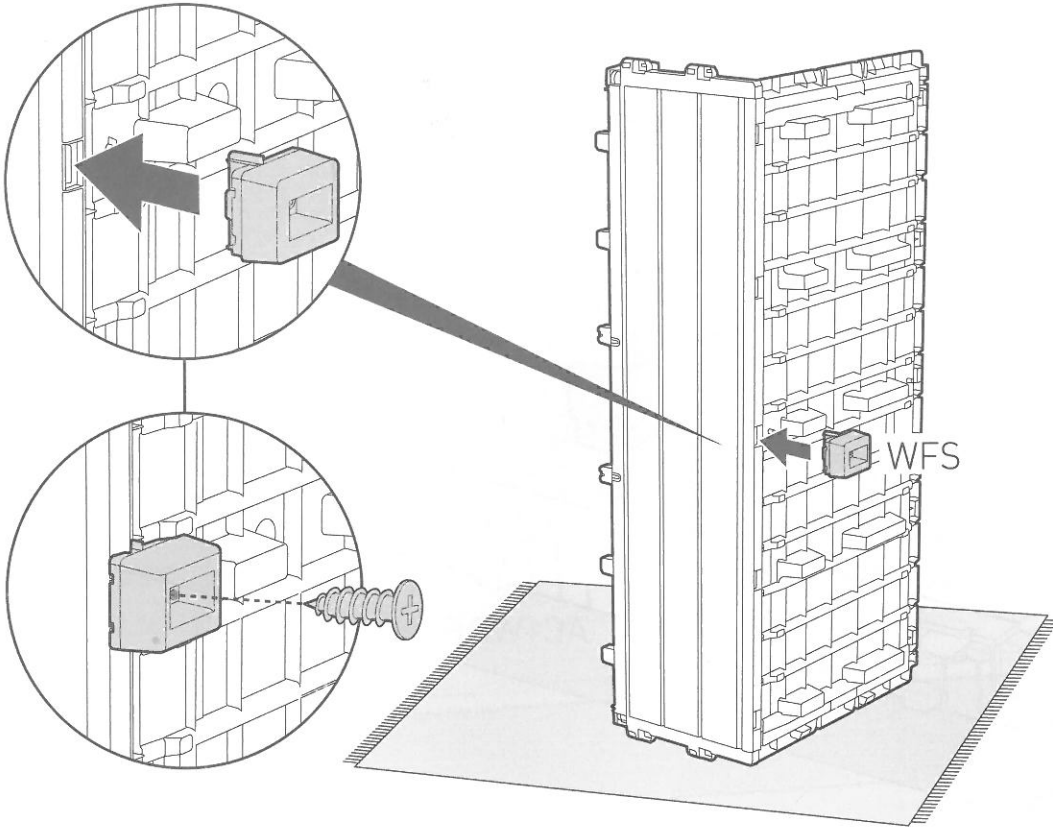

12



WPF (x1)



MP (x1)

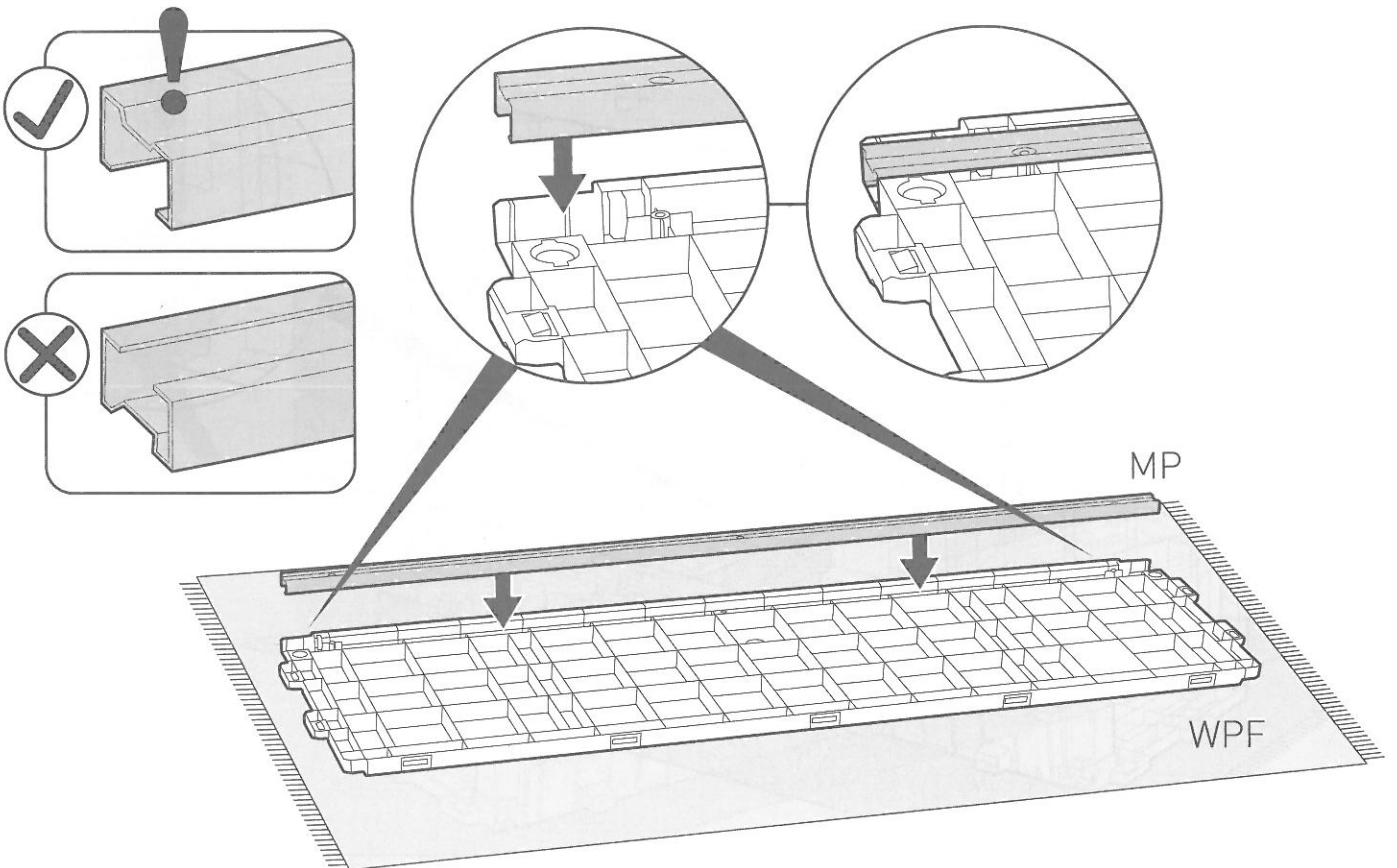

13



S (x2)

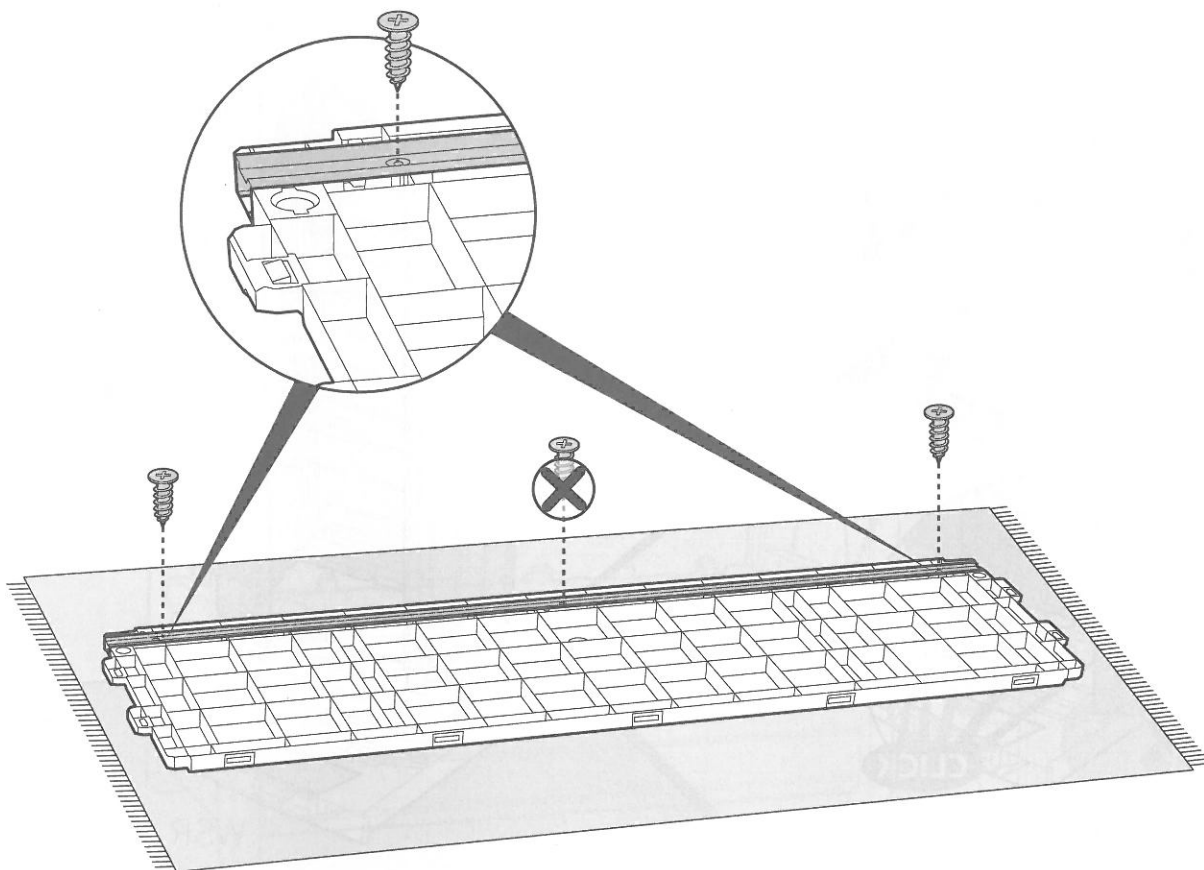

14



WPF (x1)



AC+WBP+EP (x1)

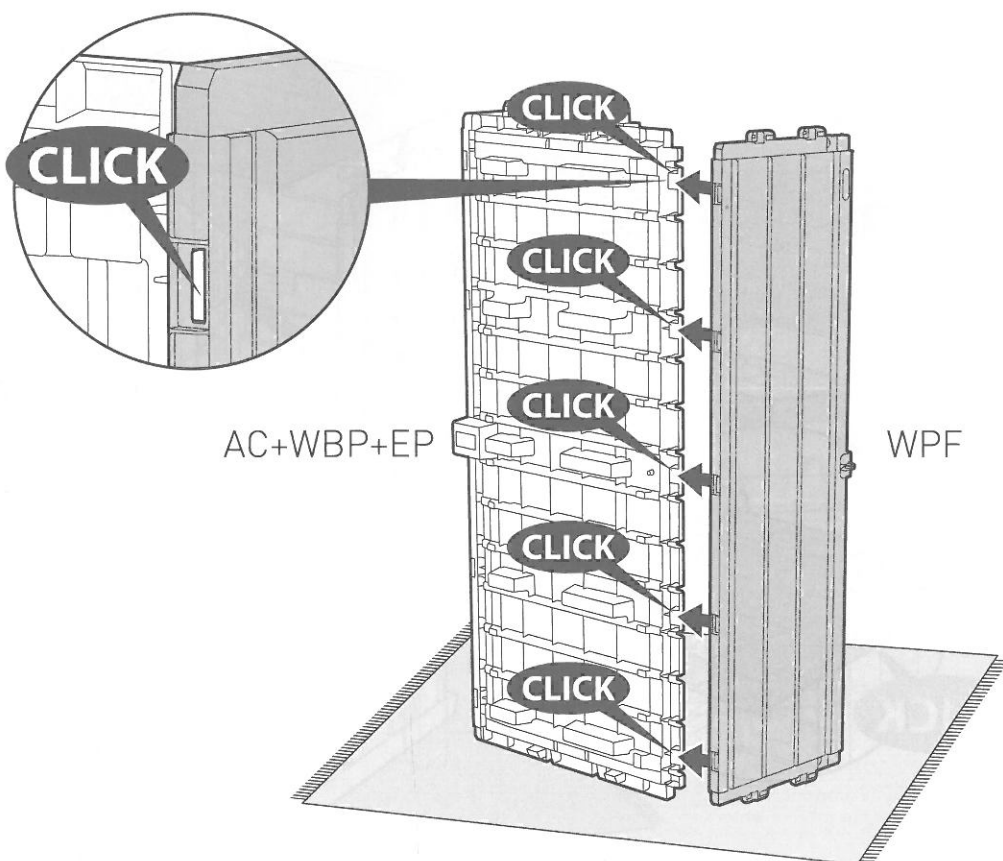

15



WSR (x1)

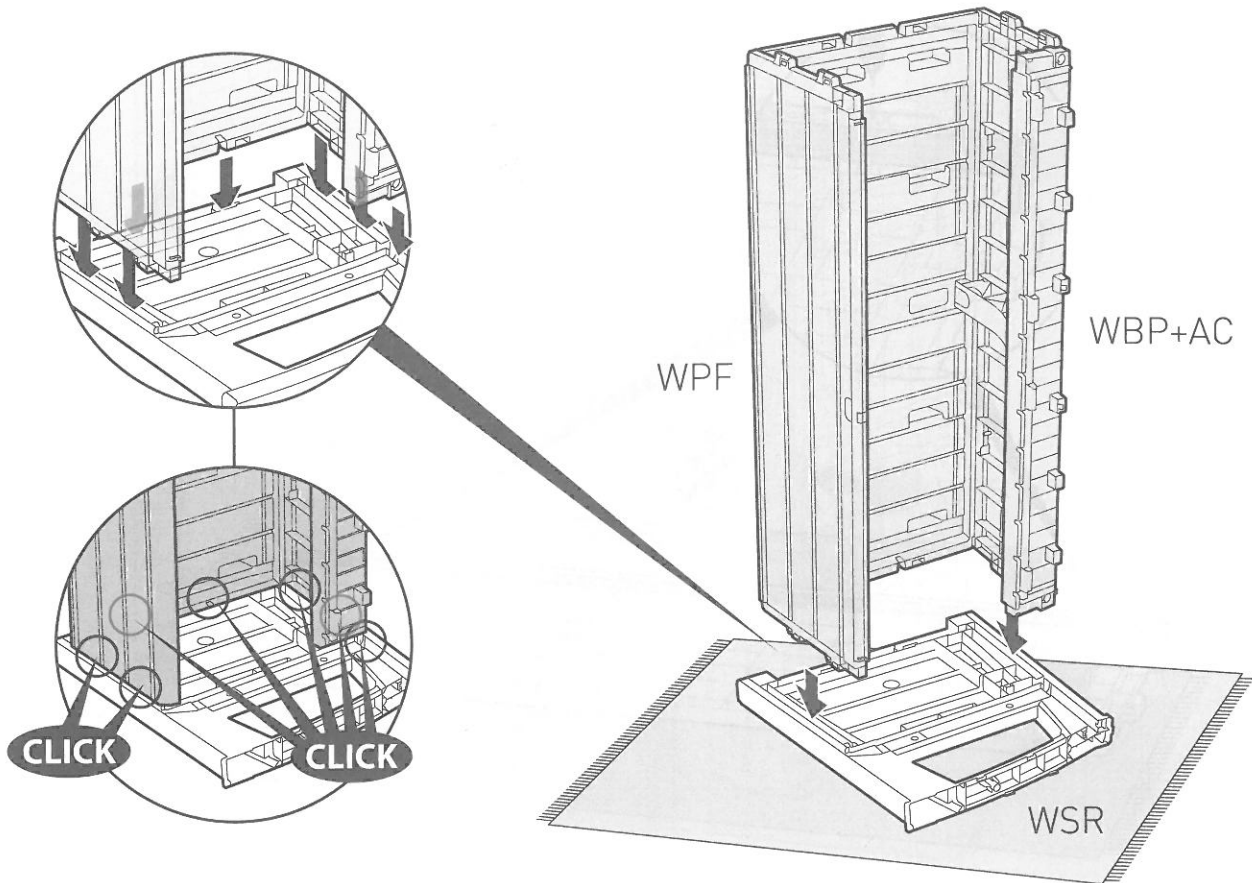

16



WSL (x1)

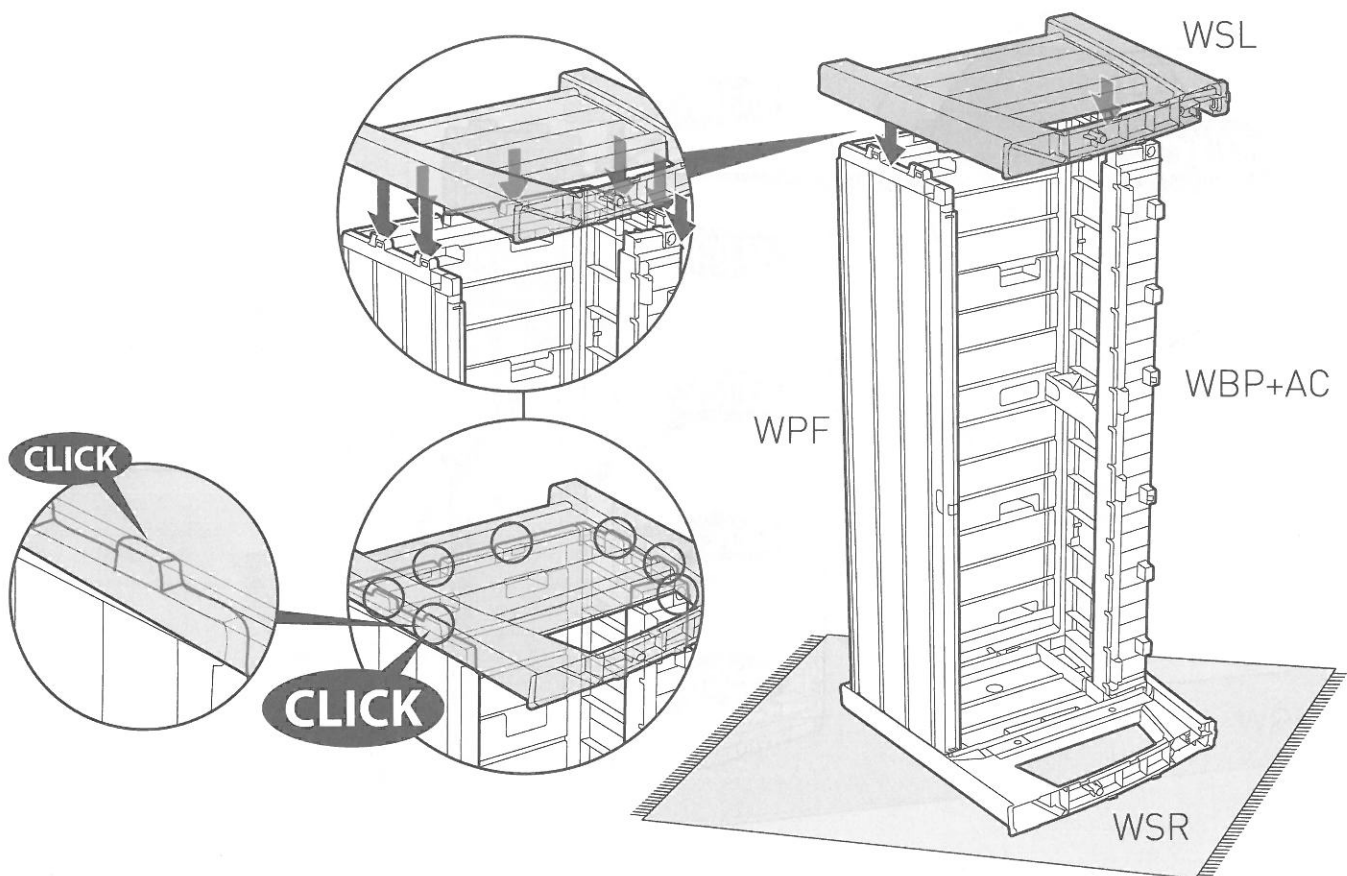

17



CP (x2)

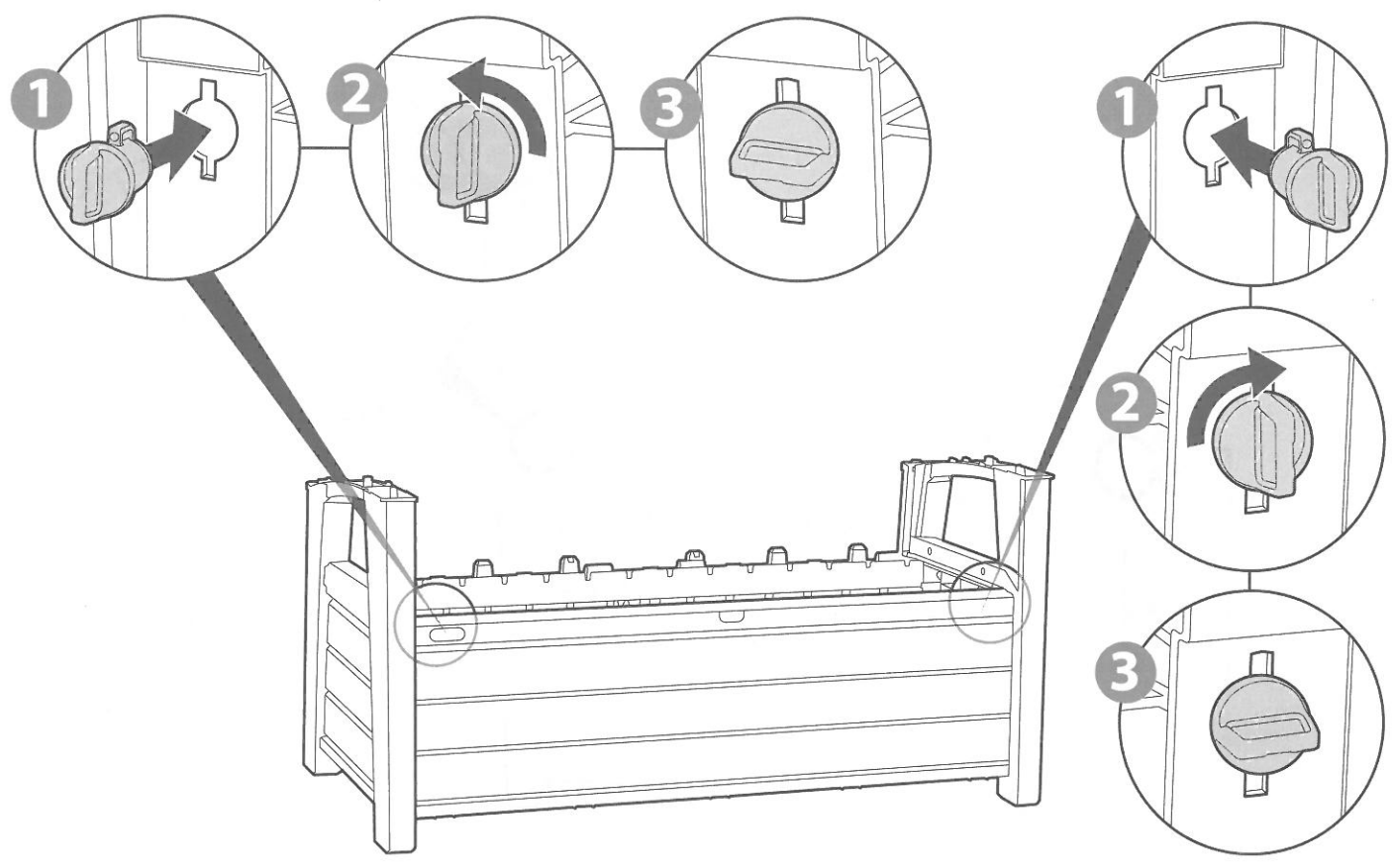

18



WBR (x1)

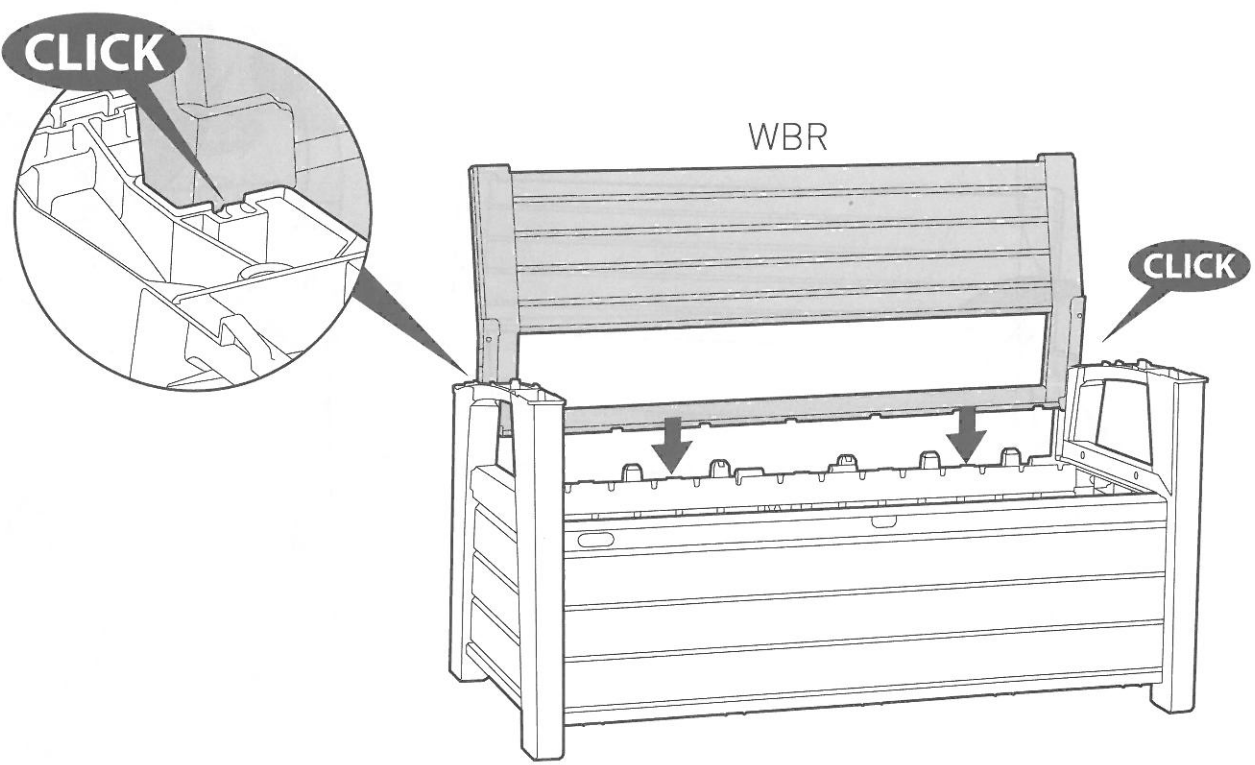

19



S (x10)

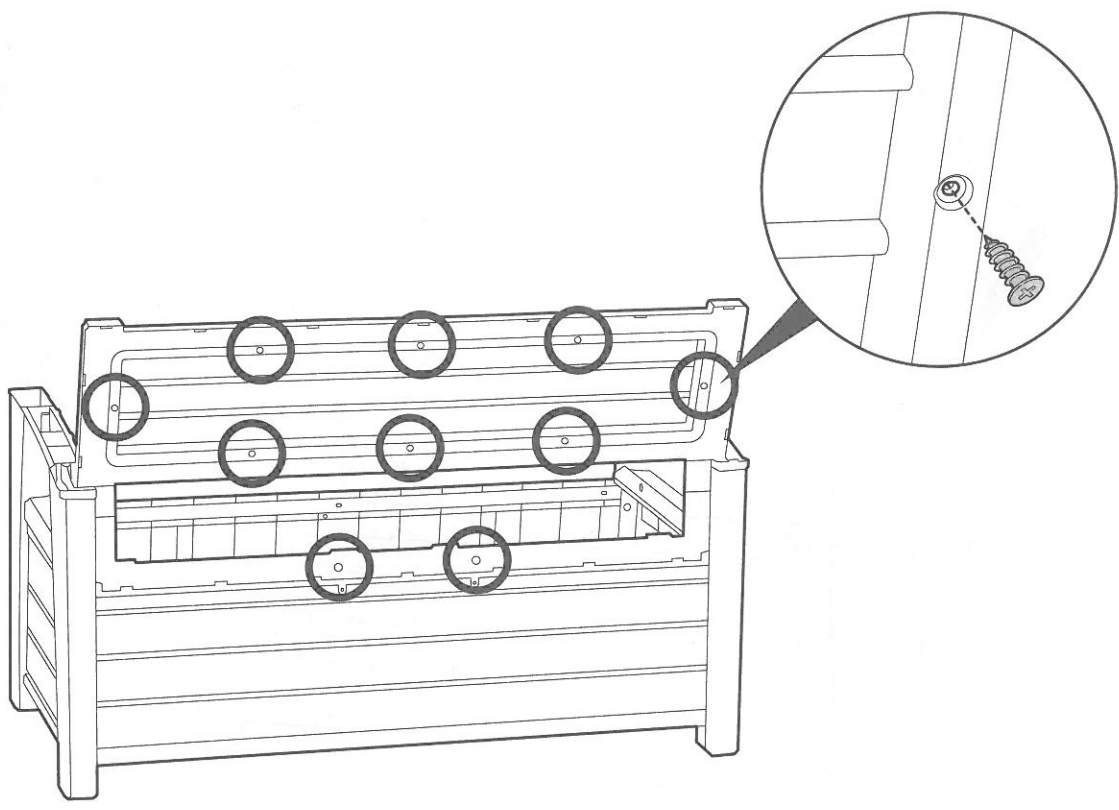

20



AL (x1)



AR (x1)

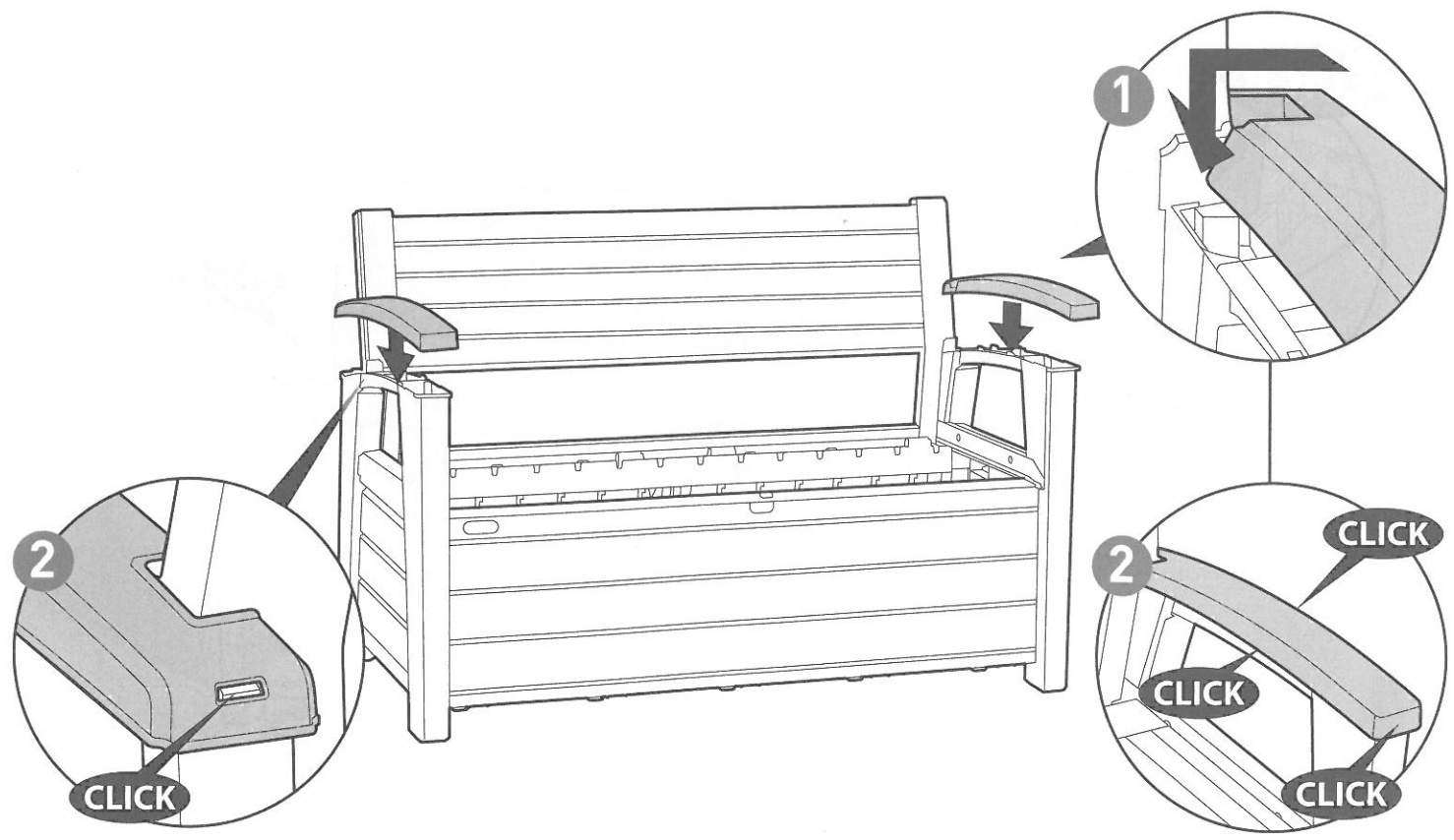

21



CBL (x1)



CFL (x1)



CBR (x1)



CFR (x1)



WLP (x1)

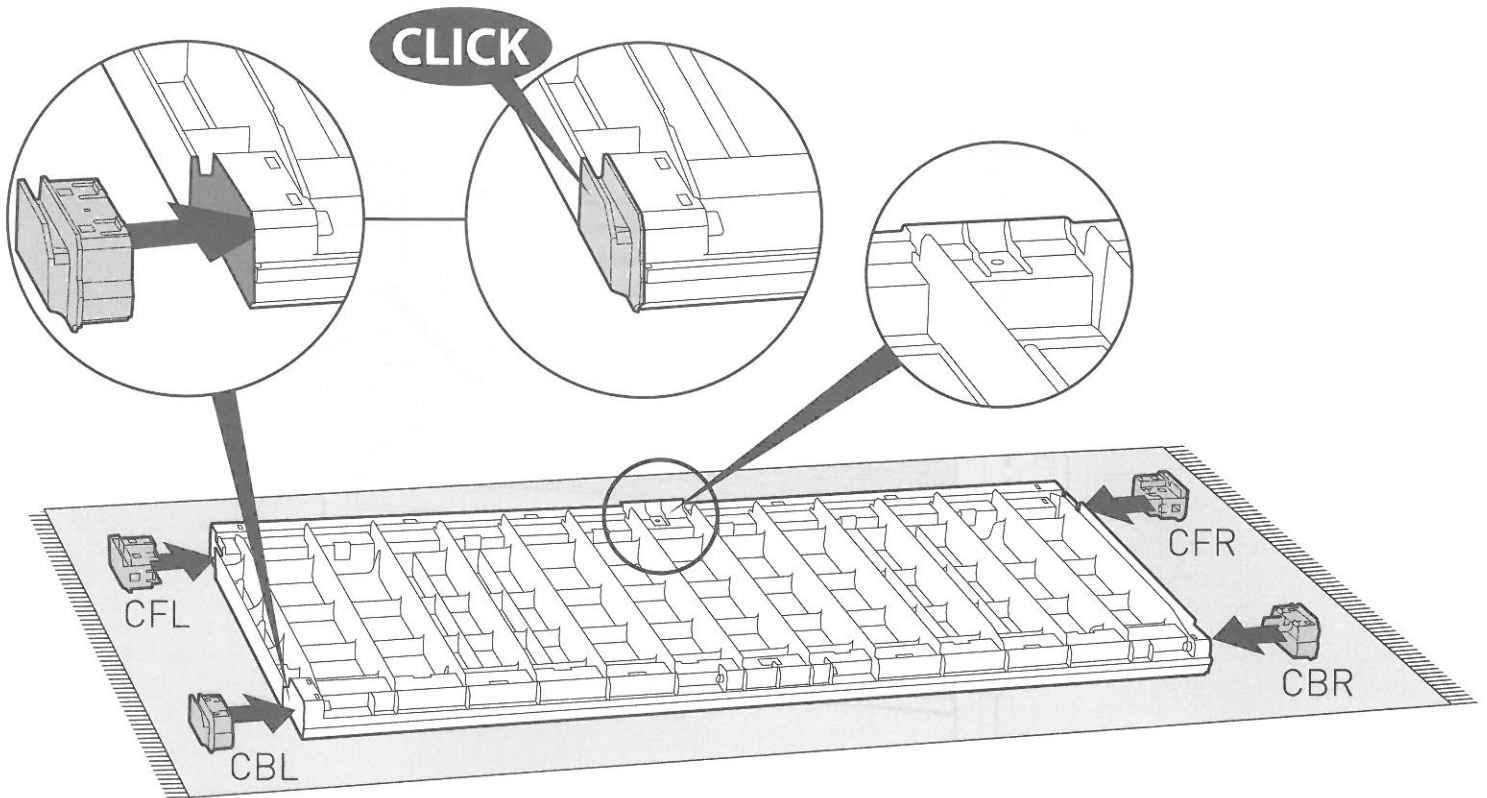

22



WLP (x1)

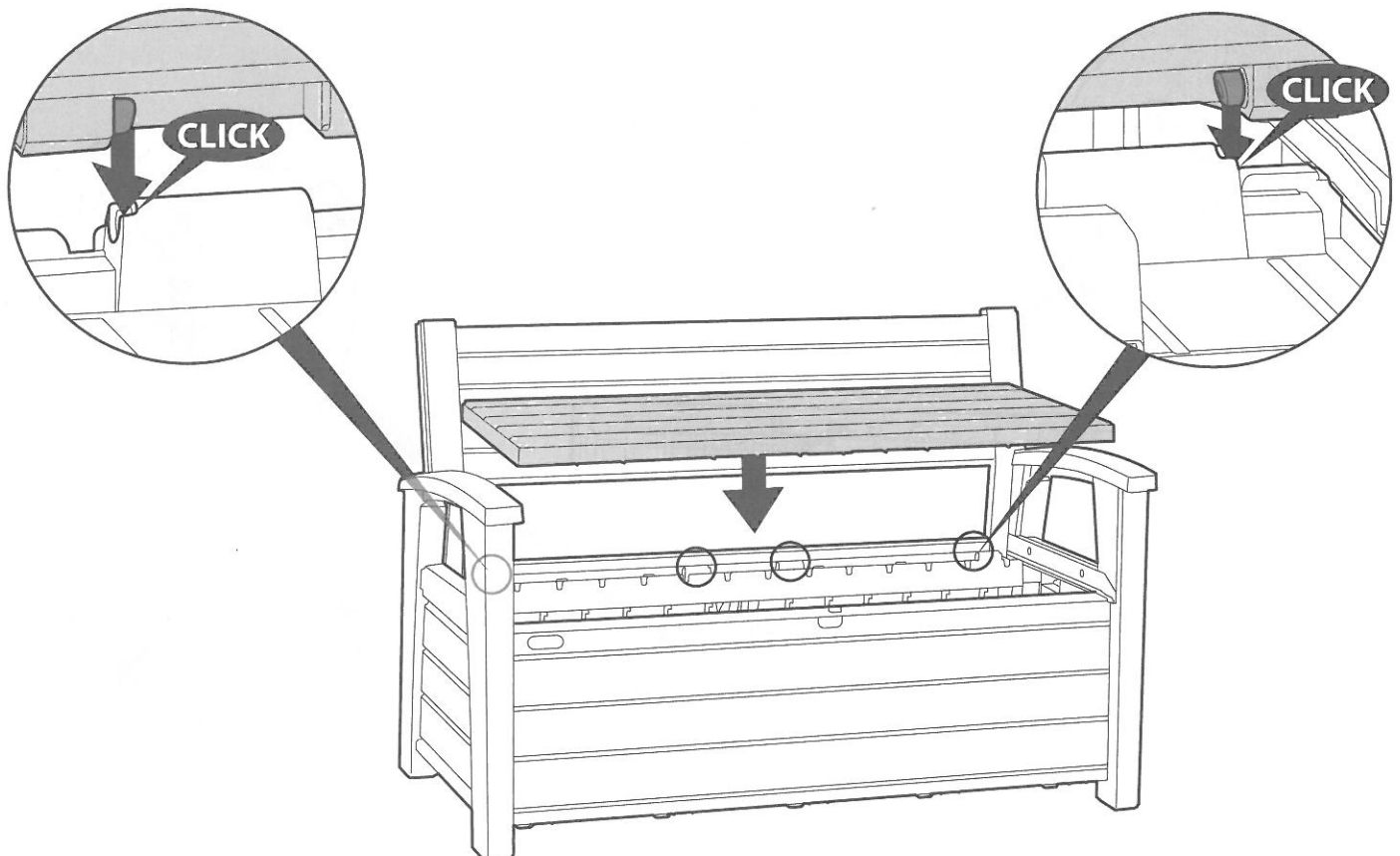

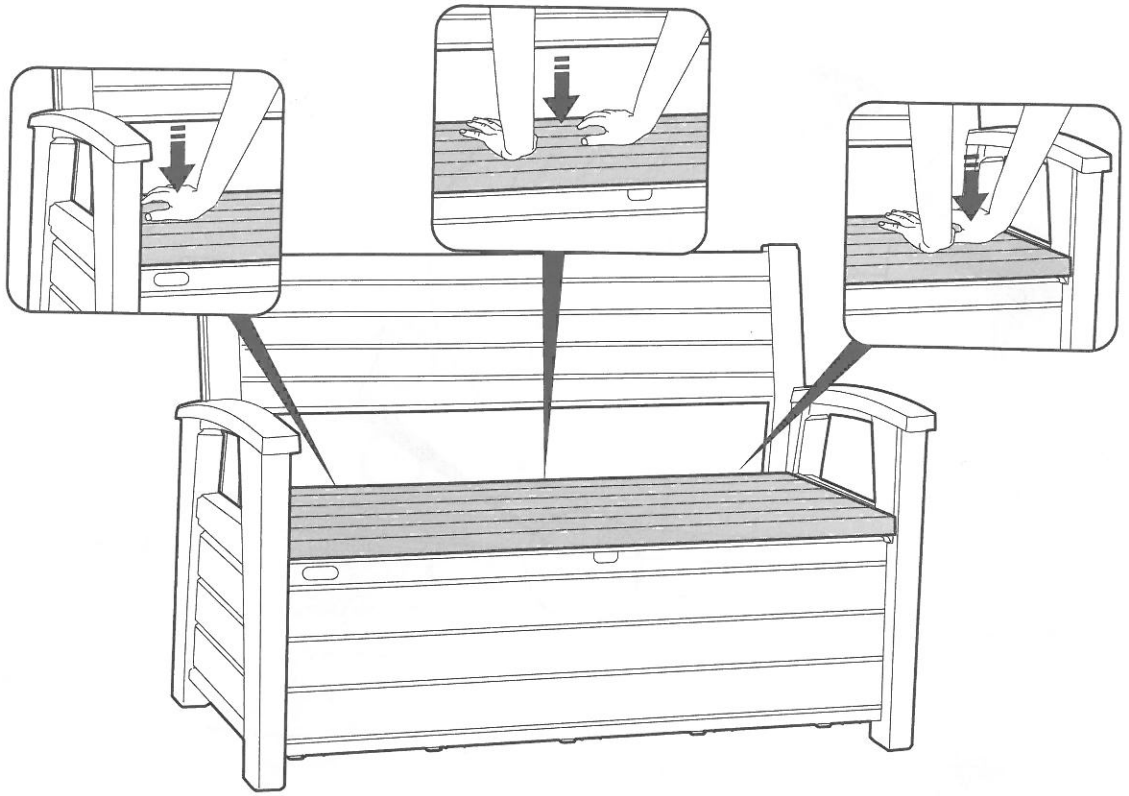

24



WL1 (x1)



WL2 (x1)



S (x2)

