

# Wall Mounted Shelf

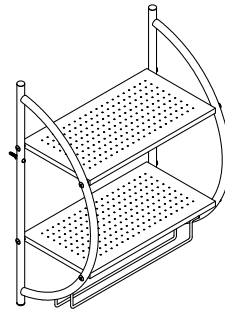

Please follow all assembly and product care instructions to ensure that your product is assembled safely and retains its high quality finish.

**PLEASE RETAIN THIS INSTRUCTION LEAFLET FOR FUTURE REFERENCE**



**ALWAYS CHECK THE PACKAGING FOR FIXINGS AND PARTS BEFORE RECYCLING OR DISPOSAL.**

**PLEASE READ THROUGH AND FULLY UNDERSTAND THE INSTRUCTION LEAFLET BEFORE STARTING THE INSTALLATION OF THIS PRODUCT.**

**ENSURE YOU HAVE ALL THE FIXINGS AND PARTS BEFORE ATTEMPTING TO ASSEMBLE OR FIT THIS PRODUCT.**

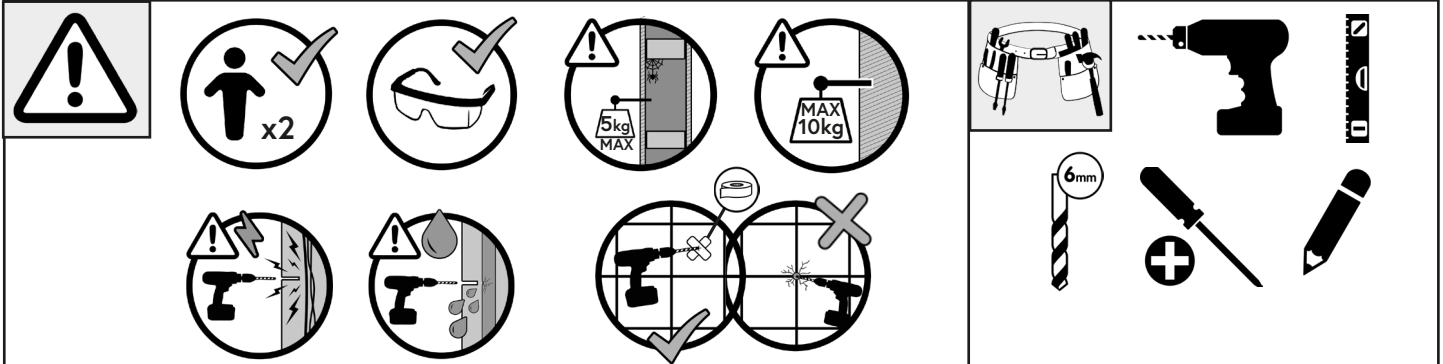

**Icon Library**



For reference only



Parts may vary. (Optional)



Warning! Please take special care.

Please read all of the information carefully and refer back when you see the numbered icons throughout instructions.

## Safety and Care

- 1 Always take care when using power tools, particularly if there is any water in the working area.
- 2 When drilling into a tiled surface do not use a hammer drill.
- 3 Always use a drill bit that is suitable for the surface that is being drilled.
- 4 Do not use power tools for assembling the product including power drills and power screwdrivers.
- 5 The wall plugs supplied are for use on solid walls only. For cavity walls or plasterboard use specialist fixings that are suitable for the type of wall construction.
- 6 For different wall types you will need to ensure that you are using the correct type of fixing for the material of the wall.
- 7 To retain the best quality finish, clean product regularly with a soft damp cloth.
- 8 Do not use abrasive or chemical cleaners, as these may damage the product.
- 9 The maximum safe working load is 5kg distributed evenly.

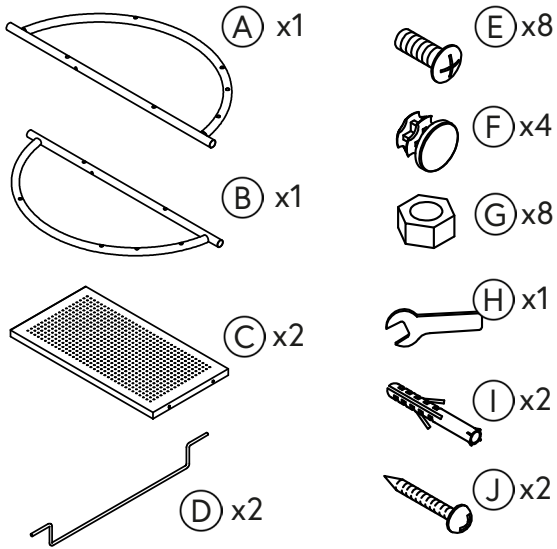

1.

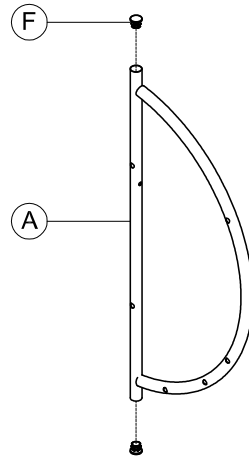

2.

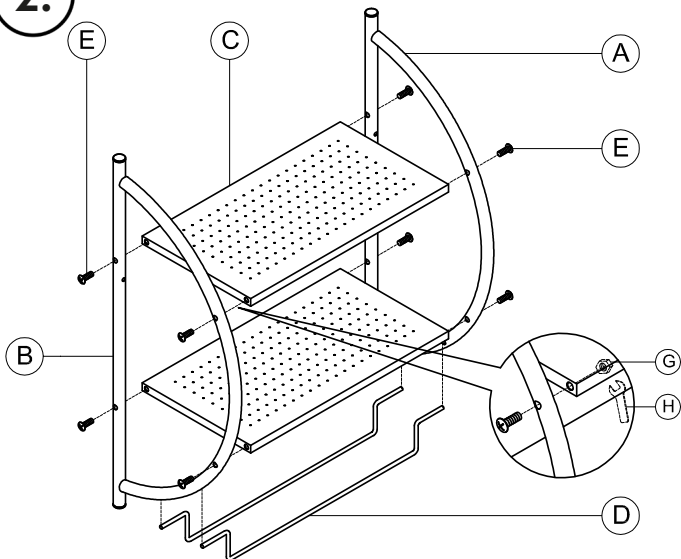

3.

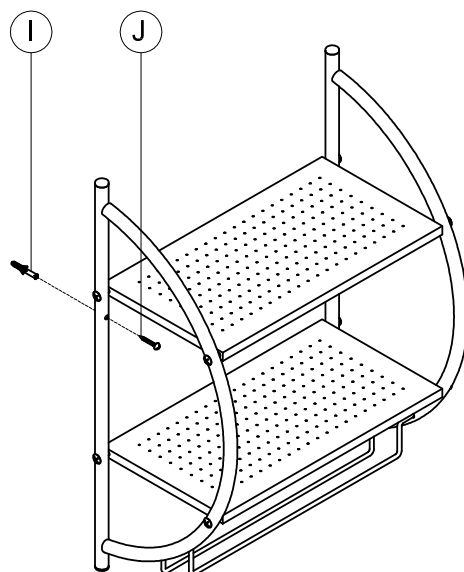

4.

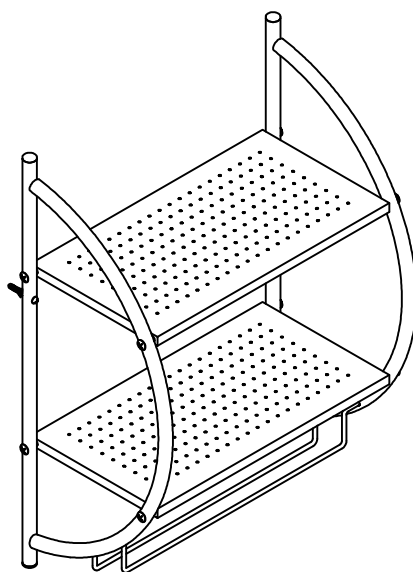

2.

UK: Croydex, Central Way, Andover, Hampshire, SP10 5AW, UK  
 EU: MIL, Unit 8 Purcellsinch Ind Est, Dublin Road, Kilkenny, R95 HP71, Ireland

+44 (0) 1264 365881  
 www.croydex.com

+44 (0) 1264 356437  
 info@croydex.co.uk

WMA 113 R03