

 **Vacmaster**<sup>®</sup>

20L | 1250W

VQ1220PFC



IPX4

UK  
CA

CE





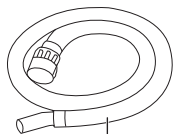
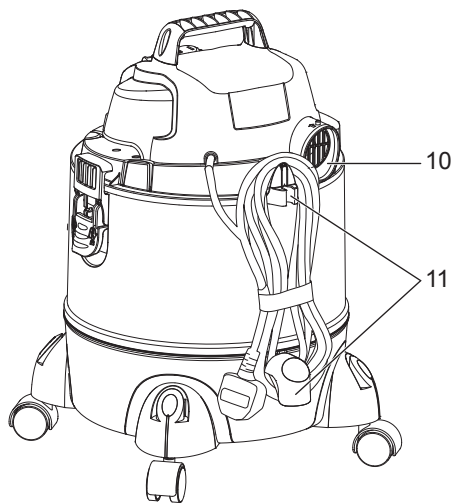
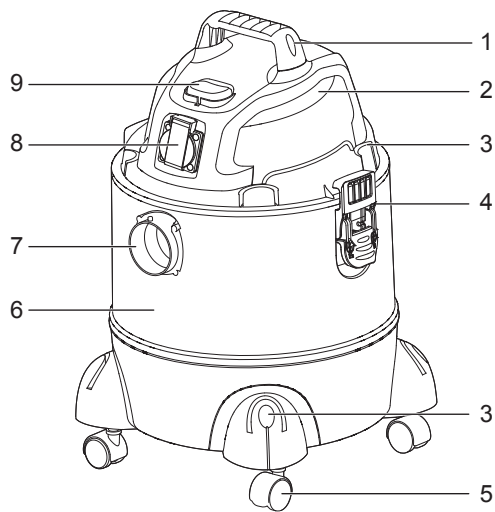

12

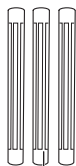

13



14



15



16

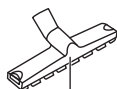

17

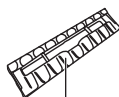

18



19



20



21



22



23



24

# TABLE OF CONTENTS

<b>SECTION</b>	<b>PAGE</b>
Safety Information .....	5
Unpacking and Checking Carton Contents .....	7
Assembly .....	8
Operation .....	9
Maintenance .....	11
Troubleshooting .....	12
Technical Data .....	13
Recycling and Disposal .....	13
Plug/Fuse Replacement (UK & Ireland Only) .....	13

Thank you for purchasing this Vacmaster® wet and dry vacuum cleaner. Feel confident that with Vacmaster® you are obtaining a high quality product engineered for optimal performance. This vacuum cleaner is suitable for use with both liquids and dry materials.

**FOR YOUR SAFETY: CAREFULLY READ AND UNDERSTAND ALL INSTRUCTIONS.**

## SAFETY INFORMATION

### **READ AND UNDERSTAND ALL INSTRUCTIONS BEFORE USING THIS VACUUM CLEANER.**

When using the equipment, a few safety precautions must be observed to avoid injuries and damage. Please read the complete operating manual with due care. Keep this manual in a safe place so that the information is always available. If you give the equipment to any other person, give them these operating instructions as well. We cannot accept any liability for damage or accidents which arise due to a failure to follow these instructions and the safety information.

- Never leave the appliance switched on unattended, if you leave the work area, switch the appliance off or unplug it from the power supply.
- Do not vacuum or use this Wet and Dry Vacuum cleaner near flammable liquids, gases or explosive vapours like gasoline or other fuels, lighter fluids, cleaners, oil-based paints, natural gas, hydrogen, or explosive dusts like coal dust, magnesium dust, grain dust or gun powder. Sparks inside the motor can ignite flammable vapours or dust.
- This vacuum cleaner is not suitable for the vacuuming of asbestos or asbestos dust.
- Do not vacuum anything that is burning or smoking, such as cigarettes, matches, or hot ashes.
- Ensure the hose and connections are always pointed away from the users face, hair, ears and eyes during operation and never direct the nozzle towards persons or animals.
- Clear the working area of any items or precessions that you do not wish to be vacuumed before operation.
- Keep cord away from heated surfaces.
- Do not expose to rain. Store indoors.
- Do not unplug by pulling on the cord. To unplug, grasp the plug, not the cord.
- Do not use with damaged cord, plug or other parts.

- Do not pull or carry by cord, use cord as handle, close a door on cord, or pull cord around sharp edges or corners.
- Do not handle the plug or vacuum cleaner with wet hands.
- To reduce the risk of health hazards from vapours or dusts, do not vacuum toxic materials.
- Frequently check that the float valve positioned underneath the motor is able to move freely.
- Do not use or store near hazardous materials.
- Do not use this vacuum cleaner with a torn filter or without the filter installed.
- Do not allow to be used as a toy. Close attention is necessary when used by or near children.
- To reduce the risk of injury from accidental starting, unplug power cord before changing or cleaning filter.
- Do not leave vacuum cleaner unattended when plugged in. Unplug from power supply when not in use and before carrying out maintenance.
- Turn off Wet and Dry Vacuum cleaner before unplugging.
- Do not cover the ventilation openings. Do not vacuum with any ventilation openings blocked; keep free of dust, lint, hair or anything that may reduce air flow.
- Keep hair, loose clothing, fingers, all parts of body away from openings and moving parts.
- If the supply cord is damaged, it must be replaced by the manufacturer, a qualified service agent or similarly qualified persons in order to avoid a hazard.
- This appliance is not intended for use by persons (including children) with reduced physical, sensory or mental capabilities, or lack of experience and knowledge, unless they have been given supervision or instruction concerning use of the appliance by a person responsible for their safety.
- Children should be supervised to ensure that they do not play with the appliance.
- For additional protection: It is recommended that this vacuum cleaner can be used in conjunction with residual current device (RCD) with a rated residual current of 30mA or less.
- Always unplug the appliance after use and before cleaning or changing the filters or accessories.

### When using as blower:

- Direct air discharge only at work area.
- Do not use Wet/Dry Vacuum as a sprayer.
- Do not direct air at bystanders.
- Keep children away when blowing.
- Wear safety goggles.

## UNPACKING AND CHECKING CARTON CONTENTS

1	Carry Handle	9	On/Off Switch	17	Hard Floor Nozzle
2	Power Head	10	Blowing Port	18	Carpet Floor Nozzle Attachment
3	Accessory Storage	11	Power Cord Storage Hooks	19	Foam Filter
4	Latch	12	Suction Hose	20	Cartridge Filter (pre-installed)
5	Caster	13	Extension Wand (x3)	21	Filter Retainer (pre-installed)
6	Container	14	Crevice Tool	22	Dust Bag
7	Suction Port	15	Round Dust Brush	23	Screw (x6)
8	Power Take-off Socket	16	Power Tool Hose Adaptor	24	Instruction Manual

# ASSEMBLY

**NOTE:** A Phillips screwdriver is required.



- 1) Remove all the contents from inside of the vacuum cleaner container.
- 2) Attach the carry handle into the slots located on the top of the power head (Fig. 1).
- 3) Turn the container upside down and insert the feet with casters into the slots and apply pressure until they click into place. Secure them with supplied screws (Fig. 2).
- 4) Your vacuum cleaner comes ready for dry vacuum cleaning with the cartridge filter pre-installed. If the cartridge filter is not installed, refer to page 9.
- 5) Optionally, for improved dust filtration, fully fit the dust bag flange onto the inlet stub (Fig. 3).
- 6) For wet vacuuming, replace the cartridge filter with the foam filter supplied. Do not use a dust bag when wet vacuuming. If the foam filter is not installed, refer to page 10.
- 7) Secure the power head back on the container, using the 2 side latches. Insert the locking end of the hose into the suction port of the container (Fig. 4).
- 8) Choose the desired accessories and/or extension wands and push fit onto the hose nozzle.

## Floor Nozzle Attachments

- 1) To remove the floor nozzle attachment, release the push clips on either side of the floor tool holder. The attachment should drop out from underneath (Fig. 5).
- 2) To insert a new floor nozzle attachment, place one side of the attachment into the bottom of the floor tool holder and secure one clip in place. Push the other side up into place and ensure it is securely fitted into the holder (Fig. 6).

## Hard Floor Nozzle

Attachment is suitable for wet or dry suction on hard floor surfaces. Ensure the squeegee is located towards the back of the floor tool holder and brushes towards the front.

## Carpet Floor Nozzle Attachment

Attachment is specifically designed for use on carpeted floor surfaces. Ensure the front lip is facing away from the user and in the direction of vacuuming.



# OPERATION

## 1. Switching On/Off

Connect the mains plug to a suitable a power outlet.

Position	Status
I	on
O	off
II	automatic synchronized start-up



## 2. Power Tool Take-Off Operation (Fig. 7)

**WARNING:** Always check the maximum wattage compatibility of the power tool take off socket against the desired power tool before connecting to prevent overloading.

- 1) Connect the power cable of your power tool to the power take-off socket.
- 2) If applicable, connect the vacuum suction hose to the dust extractor connector on your tool with the supplied adaptor.
- 3) Switch the vacuum cleaner to position II, as described in Switching ON/OFF. The moment you switch on the power tool, the vacuum cleaner will also switch on. Once the electrical appliance has been switched off, the vacuum cleaner switches off following a time lapse (around 5 second) to allow the suction tube to be emptied.

## 3. Dry & Wet Vacuum Operation

**WARNING!** ENSURE YOU READ, UNDERSTAND AND APPLY SECTION ENTITLED 'SAFETY INFORMATION'.

- 1) Verify that the correct filter is installed for wet or dry vacuuming and the container latches are secured.
- 2) Secure the locking end of the hose into the vacuum suction port.
- 3) Push the desired accessories onto the hose nozzle.
- 4) Plug the power cord into a power outlet.
- 5) Turn on the motor by assigning the switch to the "I" ON position.
- 6) Once you have completed vacuuming, switch to the "O" OFF position and unplug the power cord from the power.

**For Dry Vacuuming:**

**WARNING:** BEFORE INSTALLING, REMOVING OR CLEANING THE VACUUM CLEANER FILTER, ENSURE THAT THE POWER CORD IS UNPLUGGED AND SWITCHED OFF.

- 1) To prepare your vacuum cleaner for dry vacuuming, install the cartridge filter over the filter cage with the flat end of the filter towards the vacuum power head. Carefully push filter until it sits flush forming a tight seal.
- 2) Place the filter retainer cap on top of cartridge filter over the raised lip and tighten the retainer lock clockwise to secure against the internal filter cage (Fig. 8).
- 3) Optionally, fully fit the dust bag flange onto the inlet stub. The Vacuum cleaner can be used with or without dust bags.

**IMPORTANT:** Check the filter regular for optimal performance. An old or blocked filter will reduce suction performance.

#### **For Wet Vacuuming:**

- 1) To prepare your vacuum cleaner for wet vacuuming, remove the retainer cover and the dry use cartridge filter.
- 2) Carefully install the supplied foam filter over the internal filter cage, making sure the whole cage is covered (Fig. 9).



#### **WARNING:**

**DO NOT USE THE CARTRIDGE FILTER FOR WET VACUUMING.**

**DO NOT USE A DUST COLLECTION BAG FOR WET VACUUMING.**

**IMPORTANT!** When vacuuming large quantities of liquids, do not immerse the nozzle completely; leave a gap at the tip of the nozzle to allow air inflow. The machine is fitted with a float valve that stops the suction action when the container reaches its maximum capacity. You will notice an increase in motor noise. When this happens, turn off the machine, disconnect from power supply, and drain the liquid.

## **4. Blower Operation**



**WARNING: KEEP BYSTANDERS CLEAR FROM BLOWING DEBRIS.**



**WARNING: WEAR A DUST MASK IF BLOWING CREATES DUST THAT MIGHT BE INHALED.**

- 1) Make sure the container and any collected waste is emptied before using as a blower. This also includes removal of the dust bag.
- 2) Insert the locking end of the hose into the blowing port on the rear of the power head (Fig. 10).
- 3) Turn on the motor on by turning the switch to the 'I' ON position.

# MAINTENANCE

 **WARNING: REMOVE THE POWERCORD FROM THE POWER SUPPLY BEFORE CARRYING OUT ANY MAINTENANCE.**

- 1) Keep all safety devices, air vents and the motor housing free of dirt and dust. Use a soft, dry brush to clean the equipment regularly.
- 2) Clear all dirt or debris from the collection tank after each use. Allow to dry before replacing the power head. Do not use cleaning agents or solvents; these may damage the appliance.
- 3) Check the hose, attachments, and power cord to verify that they have not been damaged or any debris is trapped and blocking airflow.

## 1. Cleaning Cartridge Filter

Remove the filter and clean by gently tapping or brushing off dirt. For optimal performance it is recommended to replace the old filter with a new filter regularly.

## 2. Cleaning Foam Filter

Remove the foam filter and use a mild soap and water solution to wash and rinse with clean water (Fig. 11). Allow filter to air dry before installing and using again.

# TROUBLESHOOTING

**⚠ WARNING:** TO REDUCE THE RISK OF ELECTRIC SHOCK-UNPLUG BEFORE TROUBLESHOOTING.

## Cleaning Performance

Vacmaster vacuum cleaners are tested for endurance. If your motor is operating, then the most likely cause for a loss in suction is a blockage or an opening in the vacuum.

To maintain a high cleaning performance from your machine, it is important to replace or clean cartridge filters as necessary. Replace full dust bags to prevent performance drops. A performance drop with clean filters can only be caused by a blockage in the tools or the hose.

PROBLEM	POSSIBLE CAUSE	SOLUTION
The appliance does not work.	No power.	Check the power supply and fuse.
	Functional fault in the power cord, switch, or motor.	Have the damaged part checked by qualified personnel or contact the after sales helpline.
Dust is escaping from the motor cover.	The cartridge filter is missing or damaged.	Put in a cartridge filter or replace it.
	Misuse the cartridge filter when wet vacuuming, causing the damage of cartridge filter	Replace the damaged cartridge filter with a new one when dry vacuuming.
	Misuse the foam filter when dry vacuuming.	Replace the foam filter with the cartridge filter.
Power tool take-off socket does not work.	Power tool wattage is not compatible with the power tool take-off socket.	Check the wattage is compatible with the power tool take-off socket.
	Incorrect operating mode selected.	Ensure the switch is moved into position II.
Low suction power and high operating noise / vibrations.	Dust bag is full.	Replace the dust bag.
	Suction nozzle, hose, or tank inlet is blocked.	Check the suction nozzle, hose, and tank inlet for obstructions.
	Cartridge filter is blocked.	Remove the cartridge filter and clean.
	Float valve has closed.	Empty the container of any liquid waste and ensure the float valve located underneath the filter is able to move freely.

## TECHNICAL DATA

Model Number	VQ1220PFC
Motor	220-240V~50Hz
Power Input	1250W
Max. Power Consumption of the Power Tool Take-Off Socket Outlet	1740W for BS Socket
	2430W for VDE Socket
Tank Volume	20L
Net Weight	4.0 kg

## RECYCLING AND DISPOSAL

 This marking indicates that this product should not be disposed with other household wastes throughout the EU. The machine must be delivered in rigid packaging to avoid damage during transportation. The packaging and the machine itself are manufactured from recyclable materials and should be disposed of accordingly.

## PLUG/FUSE REPLACEMENT (UK & IRELAND ONLY)

This product is fitted with a non-rewirable plug. If the plug has to be changed, refer to the picture below.

