

Super**FOIL**
Insulation

Installation Guide

Flat Roof

Under Joist

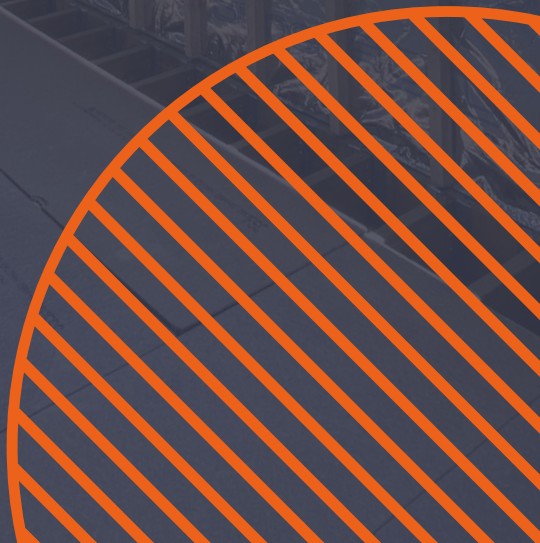

Preparing for the Installation Process

Assessments to Complete Before Installation

- Inspect the work area for any existing damage that may require repairs before re-roofing.
- Confirm and measure the insulation areas and required material quantities.
- Arrange for isolating or removing services (gas, electric, water, telephone) if needed.
- Verify that checks for asbestos-containing materials are complete.
- Plan for scaffolding or ladders, ensuring proper safety measures are in place for workers.
- Take into account the prevailing weather conditions that may impact both the timing and duration of the project.
- Plan for any shelter/tarpaulins that may be required to protect any exposed structure and insulation before, during and after installation
- Confirm any local building regulations or restrictions that need to be adhered to during the roofing job.
- Fully read this guide (before beginning installation).



Sockets & Other Wall Outlets

Sockets (plug, aerial and data) on existing walls may need to be repositioned with the need to bring cables forward. Work of this type is not classified as 'notified work' according to Approved Document P, 2013 and can be carried out by a suitably competent person. See extended detail below on electrical points.

All electrical work should be completed in accordance with Approved Document P, the relevant part of the current IEE Regulations and associated guidance.

Recommended Batten and Staple Sizes

SuperFOIL Product	Batten Size / Joist Depth	Staple Size
SF19+	38mm	14mm
SF40	50mm	20mm
SF60	63mm	25mm

Making Provisions To Electrical Points/Service Protrusions

We use the term service protrusions to indicate any feature which has to come through the SuperFOIL material to the interior of the room. These can be (not exclusively) radiator pipes, electrical points and cables, television, telephone and data cables. Where these need to come through the first layer, cut a small hole until these have been fully fed through and then carefully seal using the SuperFOIL MultiFOIL tape provided as part of the system. It is important that you carefully seal this protrusion fully so it remains properly airtight and should be carried out by a suitably competent person. Please see sections below for further information on specific situations.

If in doubt, consult a qualified Heating Engineer or electrician. All electrical work must comply with Approved Document P, the relevant IEE Regulations, and associated guidance.



Copper/plastic Radiator Pipes

When pulling copper pipes through, ensure there is enough flexibility to move them forward by approximately 100mm. Wrap the copper pipe in a non metallic insulation material to prevent direct contact with aluminium in the SuperFOIL, as this can cause a reaction. While the reaction is not harmful, avoiding it helps maintain the system's longevity.

If copper pipes need to be extended, the work should be carried out by a suitably qualified person following building regulations.

Take care when using any naked flame during the extension process, ensuring it does not come into contact with wooden battens or the SuperFOIL insulation layer.

Plastic pipes, like copper, may also need to be pulled through or extended. Additionally, adjustments to the heating system, such as relocating radiators or other components, may be required to accommodate the internal wall insulation. Any re-siting of radiators should be undertaken by a qualified professional.

Note: If in doubt, consult a qualified Heating Engineer or electrician. All electrical work must comply with Approved Document P, the relevant IEE Regulations, and associated guidance.



Maintaining Existing Ventilation To A Property

All ventilation outlets within the external wall should be maintained as required to ensure the ventilation is maintained into the property. It is important to note that where the external walls are improved in terms of thermal insulation, consideration is given to Part F of the Building Regulations – ventilation.

Internal/External Considerations

- Check that roofs, guttering, downpipes, and rainwater systems are functioning properly.
- Verify that windows are intact with no signs of water leakage.

Recommended System Components

SuperFOIL Multifoil Product

Easy to transport and lightweight rolls.



SuperFOIL Tape

High performance, reinforced, paper-backed foil tape.



Timber Battens

Treated timber battens sizes to suit the application.



Plasterboard

12.5mm standard plasterboard



Mechanical Fixings and Staples

High performance mechanical fixings to secure battens.

Appropriately sized staples as per the chart on page 3.

Plasterboard Screws.

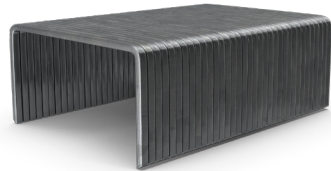

Note: Depending on the requirements of your insulation project, you may require additional materials – such as mastic sealant. If you are unsure about the suitability of any of these materials for use alongside SuperFOIL, we encourage you to contact our technical team.

Tools Required

As with all Insulation systems, a range of tools will be required in order to complete the work as easily as possible. A list of these are shown below. From our experience, the ones marked in bold are essential and should form part of your tool kit for getting SuperFOIL products installed to the highest standard possible.

Recommended Tools:

- **Hand tools:** including hammer, saw, spirit levels
- **Bladed tools:** including heavy-duty craft knives, spare blades, heavy duty shears and a rotary cutter.
- **Saws:** including a circular saw and reciprocating saw (both suitable for cutting battens)
- **Power tools:** including a drill and driver
- **Access equipment:** including ladders or scaffolding if required



Personal Protection Equipment As Required:

- **FFP3 Dust Mask**
- **Safety Goggles**
- **Hearing Protection**
- **Hard Hat**
- **Hi-Vis Vest**
- **Safety Boots**
- **Gloves**

SuperFOIL products are flexible. This means that care must be taken when these rolls are laid out over potentially hazardous materials, such as holes or sharp materials, since SuperFOIL will not support the weight of any person who walks on top of it. When SuperFOIL must be rolled out like this, we suggest using warning signs to indicate that the product must not be walked on.

Installation Details

Select an edge of the roof to begin work, complete a full run of insulation across the length of that edge before moving on to the next run.

When beginning a new run of insulation, ensure that it runs parallel to the previous run, and that it overlaps the previous run by at least 50mm. This overlap should be sealed using SuperFOIL MultiFOIL Tape or similar.

To properly secure SuperFOIL, it's important to remove excess slack on the insulation by applying gentle tension before stapling through the product into the joists. Take care to ensure that the space between each staple is no greater than 300mm and that you are using appropriately sized staples (refer to page 3 for details).

To complete the installation, install timber counter battens through the SuperFOIL product into the joists. These should be separated by spaces of no more than 600mm centres, and should be appropriately sized for the SuperFOIL product you are using (refer to table on page 3 for details).



Additional Insulation

If you are installing additional insulation, such as mineral wool or rigid PIR boards, between the joists, you must ensure that there is adequate space to accommodate this as well as the SuperFOIL.

To do so, you must allow sufficient depth for a 50mm ventilated cavity, the thickness of additional insulation, plus the required clear joist depth (refer to table on page 3 for details) for the SuperFOIL product being installed.



Joist Ventilation

In UK Building Regulations, the requirements for cold flat roofs, particularly regarding ventilation, are covered in Approved Document C: Site preparation and resistance to contaminants and moisture and Approved Document F: Ventilation.

These require the inclusion of a clear ventilation gap of at least 50mm between the insulation and the underside of the roof deck in cold roof constructions. This is intended to manage moisture and prevent condensation buildup.

If specific guidance is needed, consulting the documents mentioned above or speaking with your local building control authority is the best way to ensure your compliance.

Cutting SuperFOIL

When cutting SuperFOIL insulation, there are a few different methods to consider based on the tools available and the specific cutting needs. Below are the recommended methods:

● Utility Knife:

This method works well for standard cuts. Using a timber batten, straight edge or similar, ensure the insulation is fully compressed before cutting. This also provides a guide to maintain straight, accurate cuts.



● Electric Rotary Cutter:

This method is effective for larger projects where frequent cuts are required. The rotary-cutter provides efficient cuts with minimal effort. Before cutting, mark the cutting line on the insulation as a guide. Keeping the material pulled taut while cutting helps ensure a clean cut.



● Heavy-Duty Shears:

Ideal for use in tight spaces or areas where more control is needed. Also helpful when cutting around penetrations such as pipework, ducting etc. Mark the product before cutting to ensure accuracy. Shears allow you to cut into hard-to-reach areas while maintaining control over the material.



● Sealing the cut edges:

After cutting, it is important to seal the cut edges. Use SuperFOIL MultiFoil Tape to ensure the edges are properly sealed, helping to maintain the product's integrity and airtightness.



Importance of Sealing All Cuts and Overlaps

To ensure airtight installation the installer should take care to seal all joints (ceiling, floor, and wall) where the SuperFOIL meets an adjoining surface. Double-sided tape can also be used between joints to enhance the seal. Special attention should also be given to penetrations in the SuperFOIL, which should be sealed using SuperFOIL MultiFOIL Tape.

Please refer to page 11 and onward for specific instruction on how to best seal particular joints, junctions, and penetrations.



Importance of Airspaces in Installation

To maximise SuperFOIL's performance, ensure you are using the correct sized battens for the SuperFOIL product, this will ensure the correct airspace is achieved.

Air spaces on both sides help reduce heat conduction, and the airtight design prevents heat loss through convection. Without an airspace, radiant heat turns into conductive heat, reducing the insulation's effectiveness. Maintaining an airspace allows SuperFOIL to reflect up to 95% of radiant energy.

Penetration Detail

At penetrations – such as vent ducting, pipework, etc – you should carefully trim the SuperFOIL to allow the penetration without creating gaps around it. The point of contact between the penetration and the insulation should then be sealed using SuperFOIL MultiFOIL tape to create an airtight barrier.

This can be achieved by using small sections of tape and working around the penetration. Double-sided tape and/or mastic sealant can also be used to enhance the seal.

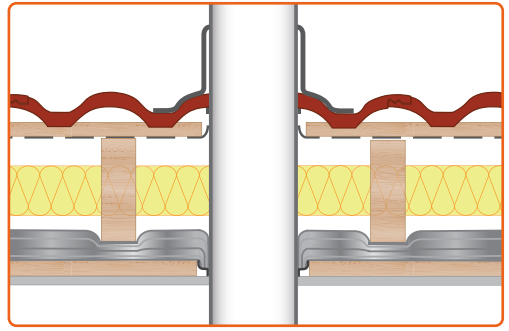

Roof to wall junction

It is essential to ensure that the roof and wall insulation overlap one another in order to prevent potential thermal bridges by creating a continuous thermal envelope.

At the junction, overlap at least 50mm of your SuperFOIL product onto the wall. If you are utilising mastic sealant or double-sided tape, this can be used to fix the overlap in place and create an initial seal.

Seal the edge of the overlap using reflective tape, then finish the junction by installing counter-battens around the perimeter of the roof-wall junction. This will firmly secure the overlap in place.

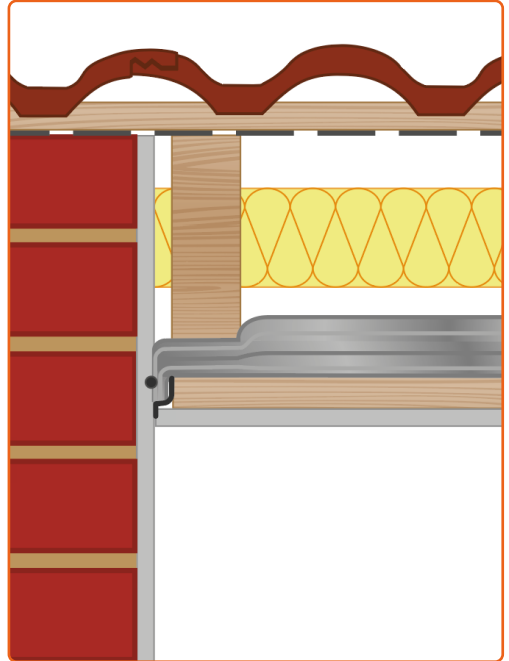

Window & Roof Lights

Begin by measuring the depth of the window reveal, noting it down to refer to later. Roll the insulation over the window and mark the edges of these reveals on the surface of the insulation. You should then extend the sides of these “window markings” inwards by an amount equal to the depth of the reveal – this creates your “cut line”.

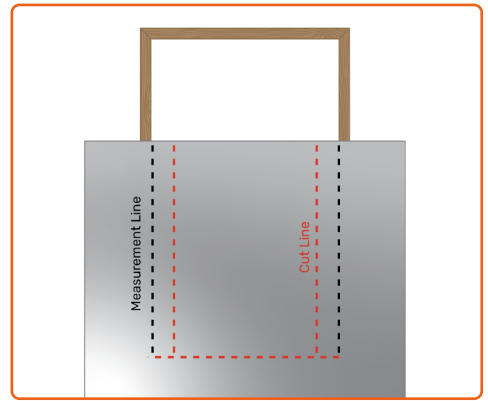

Next, using appropriate cutting tools (refer to page 9) carefully cut your insulation along this **cut line**. Afterwards, carefully seal the cut edges using SuperFOIL MultiFoil Tape before folding the new insulation flaps into the reveal, along the joists and up to the window frame.



You should then cut two additional strips of insulation to fit the top and bottom of the reveal. Measure the internal width and depth of the window reveal, this will provide the dimensions of these additional strips. Once cut to an appropriate size, these should be sealed on all edges using SuperFOIL Multifoil tape in accordance with the guidance provided on page 9.

Finally, you should install timber battens/shims to fix the SuperFOIL in place at the edge of the window frame. The combined thickness of these battens/shims and the plasterboard should not exceed the depth of the window reveal.

These battens should be installed around the perimeter of the window reveal as well as around the perimeter of the frame.

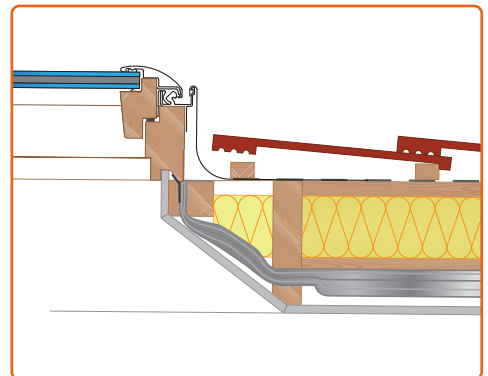

SIGN-OFF SHEET

Start Date

Completion Date

Project Name:

- Has the roof been inspected for suitability and any damage been assessed?
- Has the product been cut and trimmed to size?
- Has the product been sealed and taped at the ends before installing?
- Has the product been stapled at intervals no greater than 300mm?
- Have all joins and overlaps been taped?
- Have correctly sized counter-battens been installed at a max of 600mm centres?
- If using additional insulation, have you ensured the remaining joist depth allows for a 50mm ventilated cavity and the airspace for the SuperFOIL product?
- Has the plasterboard been installed?
- Have you taken photos of the installation process at each stage—before, during, and after completion?

Clients comments

Project managers comments

Client Signature:

Project Manager
Signature:

Date:

Date:

SuperFOIL

Insulation

Change the way you insulate.

SuperFOIL offers high-performing multifoil insulation solutions for trade contractors, professionals and DIY projects through stockists, retail and online outlets. We are committed to providing you with the best solution – through honest, expert, technical advice.



Technical support

- U-Value Calculations
- Condensation Risk Analysis
- Specification Advice
- Free Discovery Sessions



Sustainable

- 40% Recycled Material
- Minimal Wastage
- Zero Waste to Landfill
- Reduced CO2 Emission



3 In 1 Multifoil

- Reflective Foil Insulation
- Vapour Control Layer
- Radiant Barrier
- Certified High Performance



Application

- Roof, Wall & Floor
- New Build & Retrofit
- DIY Solutions
- Free Discovery Sessions

SuperFOIL

Insulation

Address UK

Boulder Developments, Boulder Business
Park, Pioneer Way, Lincoln LN6 0QR

Address EU

Boulder Developments, B.V Ground.
1st, 2nd and 3rd Floor.
Joop Geesinkweg 901 999,
Amsterdam, 1114 AB, Netherlands

 01636 639900

 technical@superfoil.co.uk

 www.superfoil.co.uk

