

ASSEMBLY & INSTALLATION INSTRUCTIONS



Focal Point Fires Ltd
Christchurch, Dorset BH23 2BT
Tel: 01202 499330
Fax: 01202 499326
www.focalpointfires.co.uk
e : sales@focalpointfires.co.uk

Focal Point Fires Ltd
RBK House, Irishtown, Athlone,
Co. Westmeath, N37 XP52,
Ireland Tel: 01202 499330
Fax: 01202 499326
www.focalpointfires.co.uk
e: sales@focalpointfires.co.uk

MODELS COVERED BY THESE INSTRUCTIONS

F820586 FPFBQ388 NEBRASKA SURROUND WALNUT VENEER

F820587 FPFBQ389 NEBRASKA SURROUND OAK VENEER

F820628 FPFBQ410 NEBRASKA SURROUND WHITE

F820879 FPFBQ832 NEBRASKA SURROUND PINE

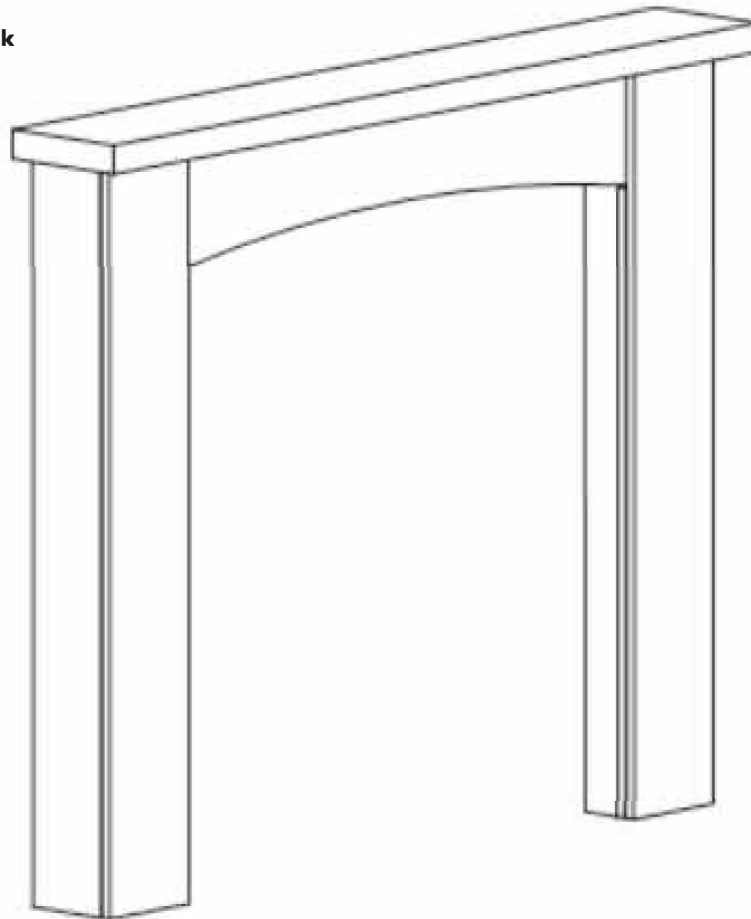

3 YEAR GUARANTEE

SUBJECT TO TERMS & CONDITIONS

For details please see: www.focalpointfires.co.uk or telephone
01202 588635 Option 4

Please note : Except where otherwise stated, all rights, including copyright in the text, images and layout of this booklet is owned by Focal Point Fires Ltd. You are not permitted to copy or adapt any of the content without the prior written permission of Focal Point Fires Ltd.

All instructions must be handed to the user for safekeeping.

Revision E - 03/22

© 2022 Focal Point Fires Ltd.

Section	Contents	Page No.
1.0	Important notes	2
2.0	Tools required	2
3.0	Hardware & parts list	2
4.0	Assembly	3
5.0	Installation	5
6.0	Cleaning/ finishing	5
7.0	Guarantee - terms and conditions	5

1.0 IMPORTANT NOTES

To ensure safe and stable installation:

1. The assembled Fire Surround must be fixed / secured to wall.
2. The wall must be sturdy and in good repair.
3. Some walls require alternative fixings (not included).
4. When drilling into the wall, check for hidden pipes and cables.

2.0 TOOLS REQUIRED

















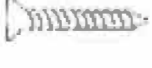

Cross head screwdriver PZ2 (3 inches in length or greater)

Drill, 6mm and a 2mm suitable drill bit

Pencil

Tape measure

3.0 HARDWARE & PARTS LIST

CODE	NAME	FIGURE	QUANTITY	CODE	NAME	FIGURE	QUANTITY
A	WOOD DOWELS (8X30mm)		15PCS	①	TOP PANEL		IPC
B	CAM LOCKS (15X12mm)		12PCS	②	FRONT PANEL		IPC
C	CAM BOLTS (6X40mm)		12PCS	③	LEFT SIDE LEG		IPC
D	WOOD SCREWS (3.5X25mm)		13PCS	④	RIGHT SIDE LEG		IPC
E	WALL SCREWS (4X30mm)		2PCS	⑤	INSIDE LEGS		3PC
F	WOOD SCREWS (3X12mm)		4PCS	⑥	LEFT SIDE PANEL		IPC
G	WALL PLUGS (6X30mm)		2PCS	⑦	RIGHT SIDE PANEL		IPC
H	MIRROR PLATES (45X43mm)		2PCS				
I	GLUE (10g)		1PCS				
J	ALLEN KEY		1PCS				
K	WOOD DOWELS (8X20mm)		4PCS				

STEP 1

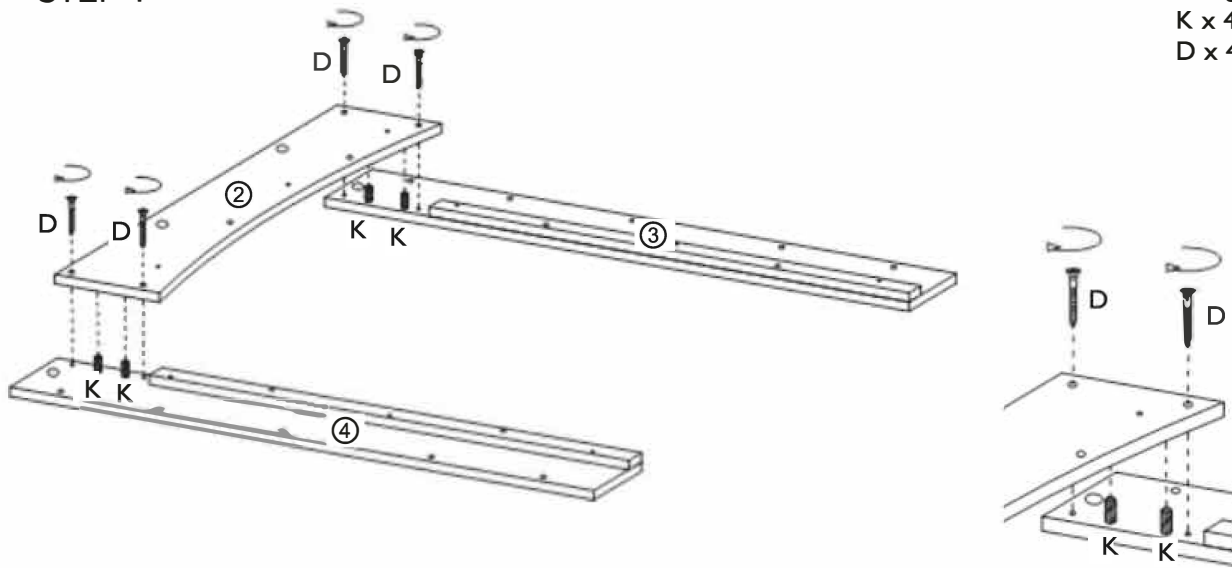

Fixings	Parts
K x 4 PCS	2
D x 4 PCS	3
	4

Gently lay both legs you have prepared onto a suitable protected surface. Be extremely careful not to scratch the front edges of the legs. **DO NOT DRAG THE LEGS!** Make sure that the legs are lifted everytime they are moved to avoid them from being damaged.

Using a drop of glue (I) in each dowel hole, insert two dowels (K) in to the left leg (3). Again, using a drop of glue (I) in the dowel holes take the front panel (2) and push them on to the dowels (K). Use 2x wood screws (D) to screw the parts together. Repeat the process for the right leg using the right leg (4) and front panel (2).

STEP 2

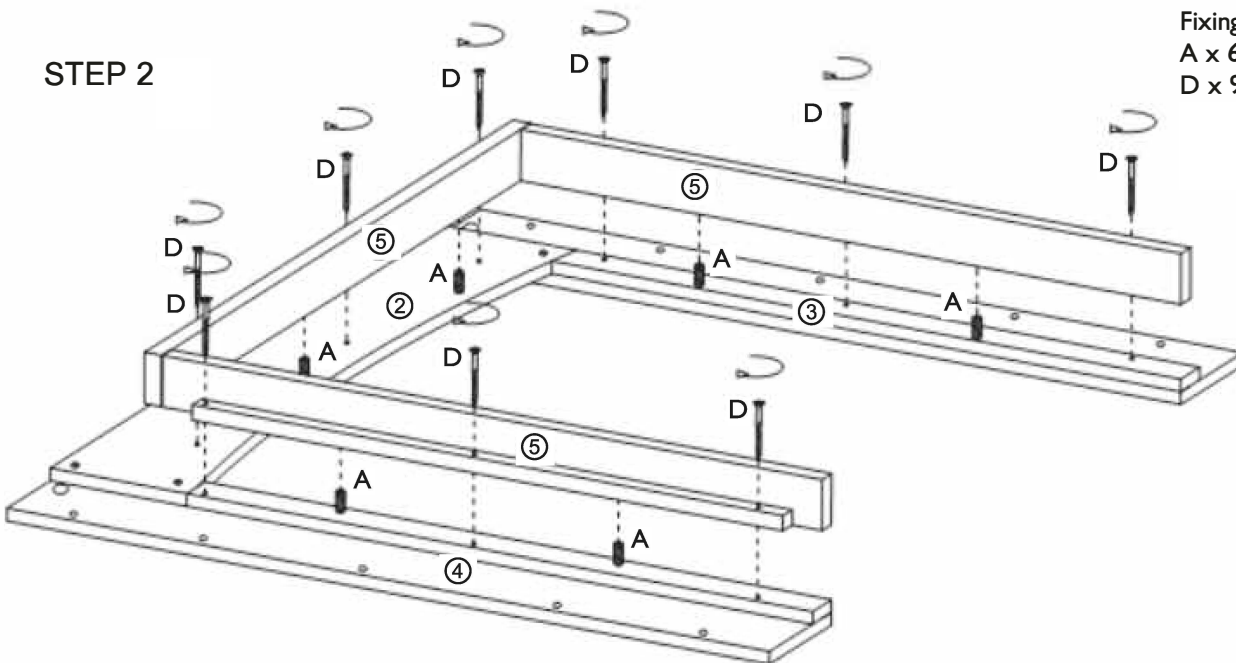

Fixings	Parts
A x 6 PCS	2
D x 9 PCS	3
	4
	5

Using a drop of glue (I) in each dowel hole, insert 2x dowels (A) in to the left leg (3). Again, using a drop of glue (I) in the dowel holes take the inside leg (5) and push them on to the dowels of the leg (3). Use 3x wood screws (D) to screw the right side panel (5) to the right leg (4). Repeat the process to secure the third inside panel (5) to the front panel (2).

STEP 3

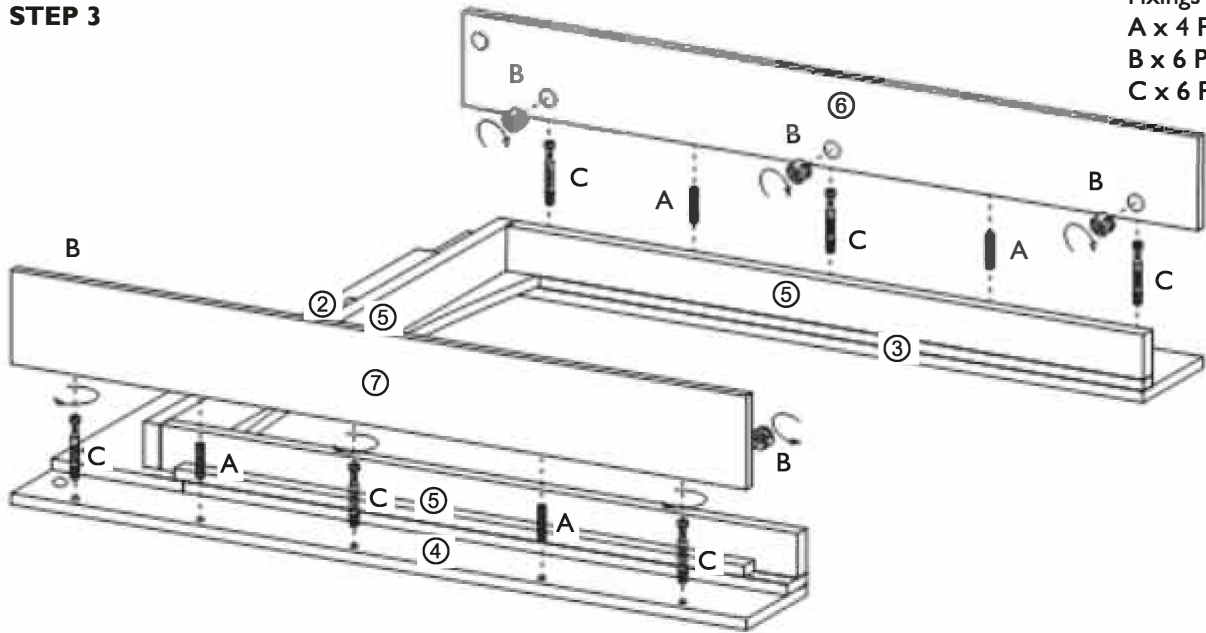

Fixings	Parts
A x 4 PCS	2
B x 6 PCS	3
C x 6 PCS	4
	6
	7

Use the Glue (I) in the dowel holes before inserting 2x dowels (A) into the left and right hand legs (3 and 4). Position the cam bolts (B) in to left and right side panels (3 and 4). Take the left side and the right side panels (6 and 7), put some glue (I) in to the dowel holes. Insert the cam locks (B). Screw the cam bolts (C) in to the left and right legs (3 and 4). Position the left and right sides (6 and 7) onto the dowel joints (A) and cam bolts (C) in the legs (3 and 4). Now turn the cam locks (B) clockwise to lock the parts together.

STEP 4

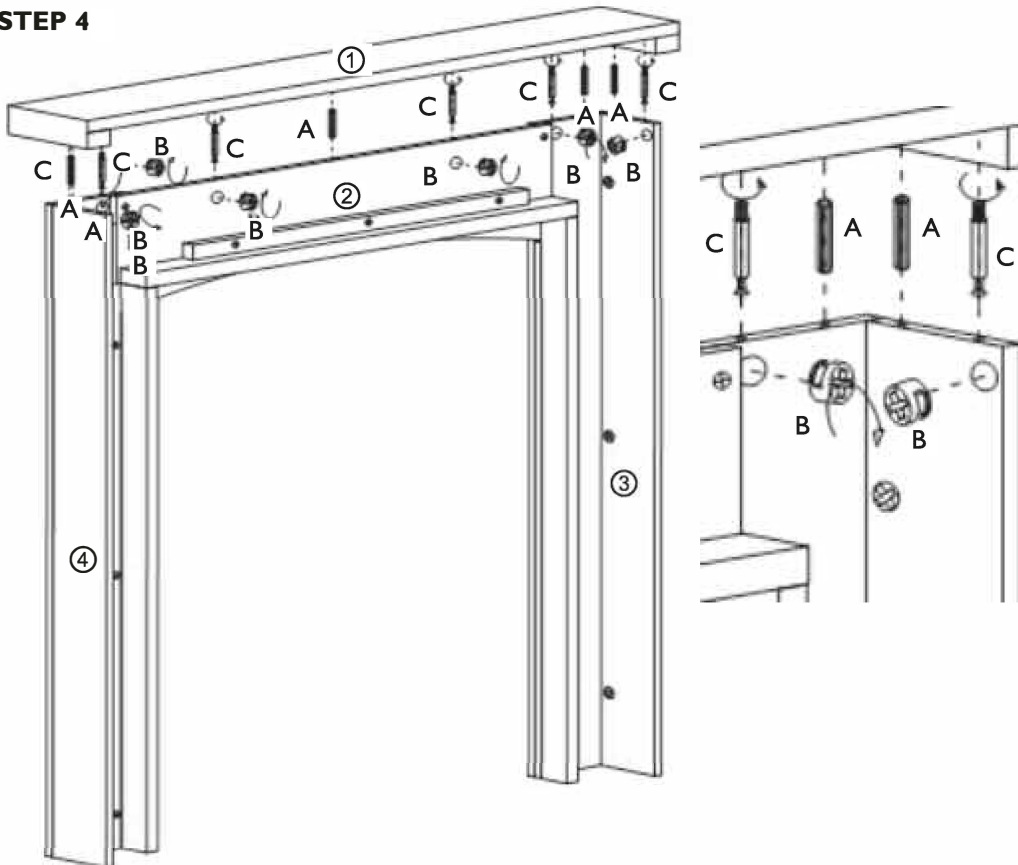

Fixings	Parts
A x 5 PCS	1
B x 6 PCS	2
C x 6 PCS	3
	4

Insert 6x cam locks (B) and glue (I) 5x dowels (A) into the legs and front panel (2,3&4). Next prepare the top panel (1) by screwing all 6x cam bolts (C) into position. The dowel joints (A) need to be glued in at both ends of the top panel. Connect the top panel to the surround, making sure all I I x inserts are in the correct position. Once home, all 6x cam locks (B) can be tightened into position.

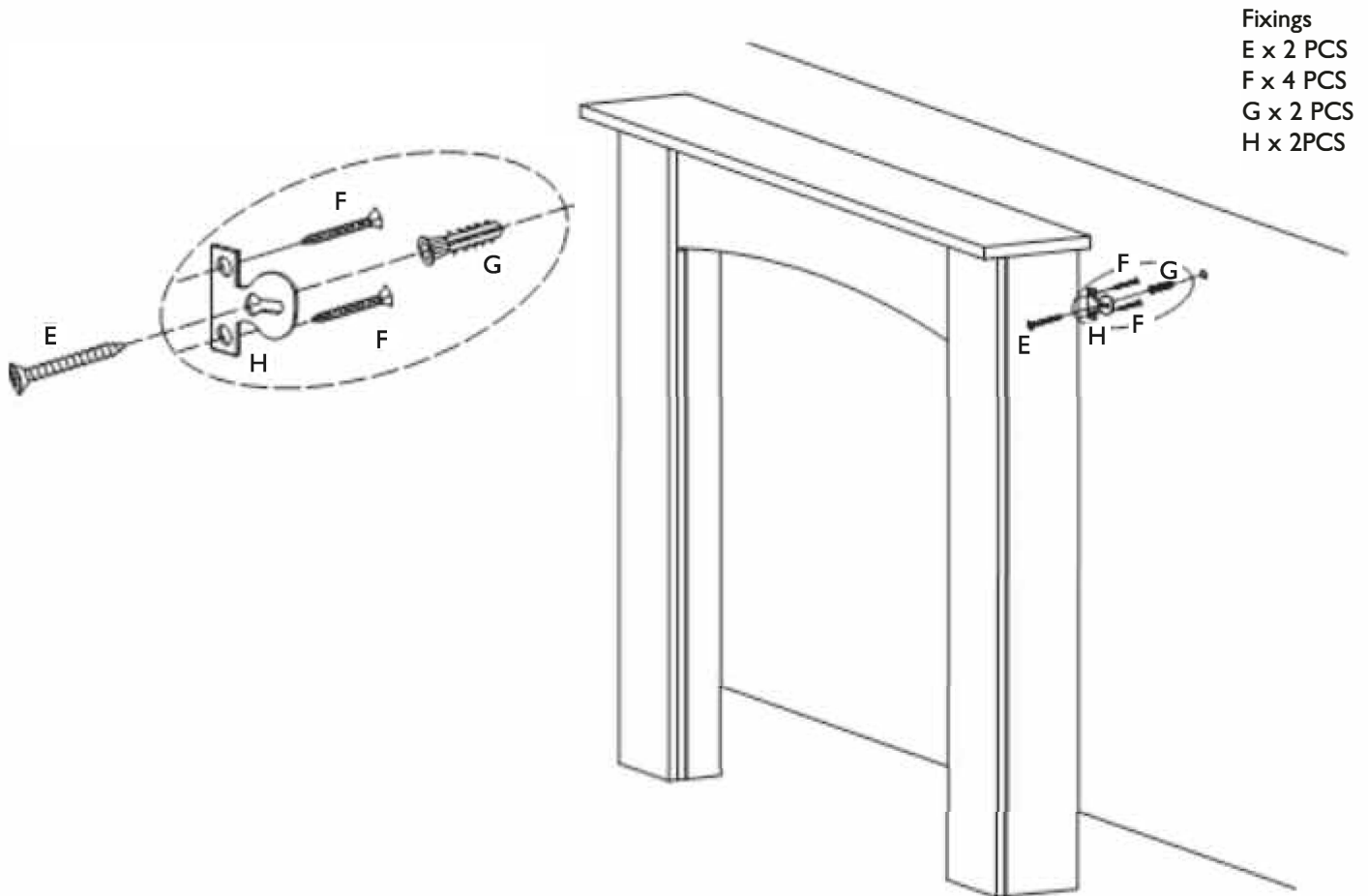

With a pencil mark out the desired height where you would like the mirror brackets (H) to be situated on the rear of the legs. To avoid splitting the leg, pre drill the bracket holes with a 2mm drill bit. Now attach the brackets to the legs using the 3x12mm screws (F). Once the brackets are in position, centre and level the hearth into its final fitting position. Position the surround on the hearth to correspond with the header/fireplace lintel, mark with a pencil on the wall where you wish to drill. Remove the surround and prepare the wall from the marked positions. If using the fixings supplied, drill a hole in the wall using a 6mm drill bit. If not, use a suitable drill bit for the wall plugs you are using. Insert the wall plugs (G) into position. Offering the surround back up into position against the wall, you are now able to secure the surround to the wall using the 4x30mm screws (E).

6.0 CLEANING/ FINISHING

Before carrying out any of the following operations, ensure that the appliance is OFF and completely cold. Regularly clean around the appliance to ensure that dust, fluff, pet hair etc, are kept to a minimum. There are no other specific requirements for care, other than regular cleaning of the general appliance.

A wipe with a dry cloth is normally sufficient. **DO NOT** use abrasive cleaners as they can damage the finish. Test on a hidden part before cleaning. Clean only in the direction of the grain. Regularly check the surround is securely fixed in position.

7.0 GUARANTEE - TERMS AND CONDITIONS

The 3 year guarantee commences from the date of purchase, provided that the terms and conditions are adhered to:

Registration is not required.

1. For any claim to be made within the 3 years from date of purchase you will be required to provide and supply us with your proof of purchase.

Making a claim is easy.

If you wish to make a claim under our 3 year guarantee and all the terms and conditions for your product have been met then please submit the following information for the attention of the 3G Service Department to the address below. Alternatively, you can email or fax. Please note that this does not affect your statutory rights.

Focal Point Fires Ltd, 3G Service Department, Reid Street, Christchurch, Dorset, BH23 2BT.
 Alternatively email: 3g@focalpointfires.co.uk or fax. 01202 499326.

Details required:

1. Name, full address including post code and contact telephone number.
2. Receipt of purchase or credit card statement.