

N 50, built-in freezer, 82 x 59.8 cm, flat hinge
GU7212FE0G



COOKING PASSION SINCE 1877



Built-under freezer with No Frost and Door Alarm for convenient and worry-free freezing where space is limited.

- ✓ No Frost – No more defrosting your freezer.
- ✓ Home Connect – Add your smart fridge to your home network and stay connected to your kitchen.
- ✓ Flex Door Storage - Additional space for all your bottled needs.
- ✓ Made in Germany - Made with quality that lasts.

Features

Technical Data

Energy Efficiency Class (Regulation (EU) 2017/1369) : E
Average annual energy consumption in kilowatt hour per year (kWh/a) : 189 kWh/annum
Sum of volume of frozen compartments : 85 l
Airborne acoustical noise emissions : 35 dB(A) re 1 pW
Airborne acoustical noise emission class : B
Light : No
Product category : Upright freezer
Built-in / Free-standing : Built-in
Frost free system : Fridge and freezer
Height of the appliance : 820 mm
Width of the appliance : 598 mm
Depth of the product : 548 mm
Dimensions of the packed product (HxWxD) : 890 x 620 x 670 mm
Net weight : 36.9 kg
Gross weight : 39.7 kg
Fuse protection : 10 A
Frequency : 50 Hz
Length electrical supply cord : 230.0 cm
Door hinge : Right reversible
Warning signal / malfunction : Visual
Lockable door : No
Number of drawers/baskets (Stck) : 3
Number of freezing flaps (Stck) : 0
EAN code : 4242004272052
Brand : Neff
Product name / Commercial code : GU7212FE0G
Product category : Upright freezer
Included accessories : 1 x ice cube tray



4 242004 272052

N 50, built-in freezer, 82 x 59.8 cm, flat hinge
GU7212FEOG



COOKING PASSION SINCE 1877

Features

Performance and consumption

- Energy Class: E
- Total Volume: 85 l
- Annual Energy Consumption: 189 kWh/a
- Climate Class: SN-T
- Noise Level : 35 dB , B Class

Design and Styling

Convenience & Safety

- No Frost
- LED electronic control
- Special mode(s): Economy setting, Sabbath mode
- Optical and Acoustic Warning System by Temperatur increase
- Super Freezing: Manual/automatic activation
- Connected appliance: Remote Monitoring and Control, iService Remote
- Easy clean interior

Freezer

- Net Freezer Volume : 85 l
- 3 transparent freezer drawers
- Temperature rise time : 9 H
- Fast Freeze Facility
- Freezing capacity 24h: 8 kg
- Freezer compartment suited for Pizzas

Technical Information

- Door right hinged, reversible
- can be built under
- Ventilation in plinth, no cut-out in the countertop necessary
- Length of power cord: 230 cm
- Nominal voltage: 220 - 240 V

Dimensions

- Niche Dimension (H x W x D): 82.0 cm x 60.0 cm x 55.0 cm
- Appliance Dimensions (H x W x D): 82 cm x 59.8 cm x 54.8 cm

Accessories

- Accessories: 1 x ice cube tray

Country Specific Options

- Based on the results of the standard 24-hour test. Actual consumption depends on usage/position of the appliance.

General Information

N 50, built-in freezer, 82 x 59.8 cm, flat hinge
GU7212FE0G

Dimensioned drawings

Maximal permissible weight of the unit fronts

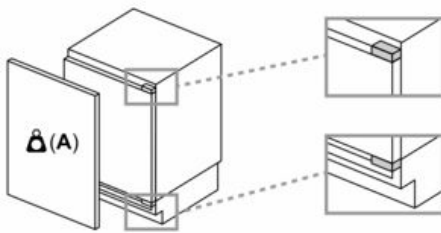

Fitted unit fronts that exceed the permissible weight may cause damage and result in functional impairment of the hinges

A: Weight ≤ 14 kg

Measurements in mm

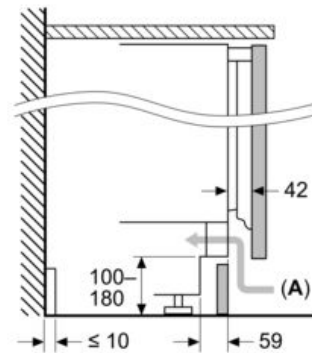

A: Air inlet ≥ 200 cm²

Measurements in mm

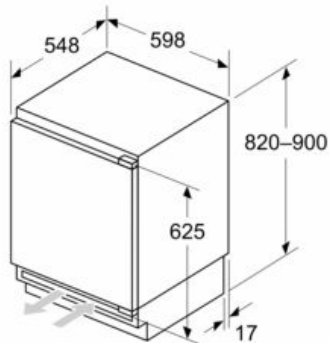

measurements in mm

Recommended gap dimensions for flat hinges

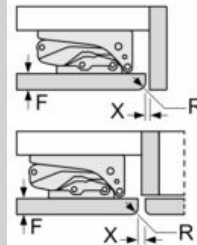

| F | R | X |
|-------|-----|-----|
| 16-19 | 0-3 | 2.5 |
| 20 | 0-1 | 3 |
| | 2-3 | 2.5 |
| 21 | 0-1 | 3 |
| | 2-3 | 2.5 |
| 22 | 0 | 4 |
| | 1 | 3.5 |
| | 2-3 | 3 |

The gap dimensions recommended in the table must be adhered to in order to ensure that appliance doors do not collide with anything when they are opened, and to avoid causing damage to kitchen units.

Measurements in mm

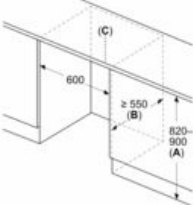

A: Substructure height
B: ≥ 560 mm (recommended)
C: Special accessory can be ordered in case screwing is not possible
Space for electrical connection next to the appliance on the left or right side