

N 70, BUILT-IN WARMING DRAWER, 60 X 14 CM,  
 STAINLESS STEEL  
 N24HA11N1B



#### Optional accessories

Z11SZ60G0 SeamlessCombination 45 + 14cm

Preheat plates and cups, so that dishes stay hot longer. Keep warm, for keeping cooked dishes warm.

- ✓ Slow Cook Programme - For tender meats, poultry, and vegetables packed with flavour and vitamins.
- ✓ Plate Warmer - Keep your food at the right temperature from kitchen to table.
- ✓ Cup Warmer - Prepare your cups for coffee and tea, whenever and wherever!
- ✓ Installation with compact appliance – combine your drawer with any 45 cm appliance
- ✓ Push & Pull – open or close your drawer with a gentle tap on its seamless surface

#### Features

##### Technical Data

Construction type: ..... Built-in  
 Maximum number of plates: ..... 12  
 Maximum number of espresso cups: ..... 64  
 Dimensions: ..... 140 x 594 x 518 mm  
 Dimensions of the packed product (HxWxD): . 250 x 660 x 700 mm  
 Min. required niche size for installation (HxWxD): . 140 x 560 x 550 mm  
 EAN code: .....4242004266921  
 Fuse protection: ..... 10 A  
 Voltage: ..... 220-240 V  
 Frequency: ..... 50-60 Hz  
 Plug type: ..... GB plug



*N 70, BUILT-IN WARMING DRAWER, 60 X 14 CM,  
STAINLESS STEEL  
N24HA11N1B*

#### Features

- Multifunctional warming drawer with the heating functions: Low temperature cooking, Keep warm, plate warming, cup warming
- Can accommodate up to:
  - -12 plates
  - -64 espresso cups

#### Design

- Graphite-Grey Edition
- Touch key operation
- Touch Control illuminated

#### Programmes/functions

- Temperature control in 4 levels: ca. 30°C - 80°C (glass surface temperature)
- User-friendly electronics: extremely
- easy and comfortable operation
- Favourites button - manage via Home Connect app
- Easy to clean toughened glass heating plate
- Push-Pull opening mechanism

#### Performance/technical information

- Nominal voltage: 220 - 240 V
- Total connected load electric: 0.82 KW
- Cavity volume: 20 l
- Loading up to 25 kg
- Appliance dimension (hxwxh): 140 mm x 594 mm x 518 mm
- Niche dimension (hxwxh): 140 mm x 560 mm - 568 mm x 550 mm
- In case of installation under the worktop, installation accessory spare part no. 9001698838 is needed.
- Please refer to the dimensions provided in the installation manual

N 70, BUILT-IN WARMING DRAWER, 60 X 14 CM,  
 STAINLESS STEEL  
 N24HA11N1B

## Dimensioned drawings

## Measurements in mm

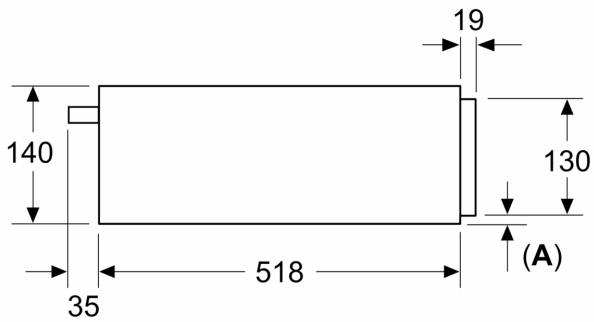

**A:** 7.5 mm

Compact ovens with appliance height of 455 mm can be installed above the warming drawer without an intermediate floor

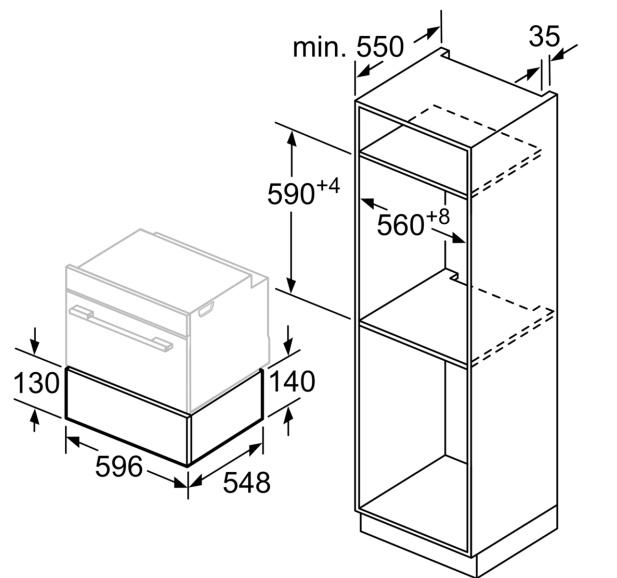

measurements in mm