

Alure Thermostatic Mixer shower

Fitting instructions

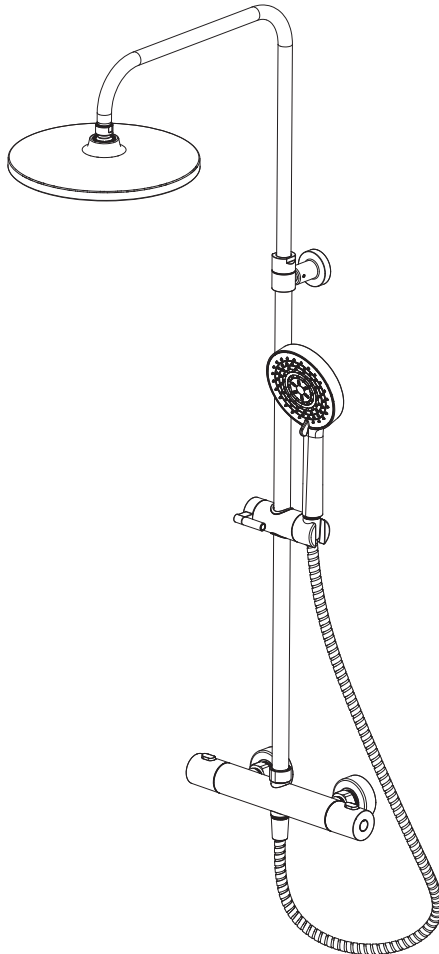

Please note: Tap head shown is for illustration purposes only.
Please keep these instructions for future reference and request of replacement parts.

We have taken great care to ensure that this product reaches you in perfect condition. However should any parts be damaged or missing please contact your point of purchase. This does not affect your statutory rights. In addition if you require replacement parts your point of purchase will be happy to assist.

Contents	Page
1. General Information	2
2. Tools Required	3
3. Parts Supplied	3
4. Before You Start	4
5. Water Supply Temperature	4
6. Installation	5-9
7. Temperature Setting	10
8. Aftercare	11-12
9. Troubleshooting	13

General Information

This product must be fitted in compliance with the UK Water Supply (Fittings) Regulations. If in doubt please contact your local water authority.

Tools Required

(Tools not supplied)

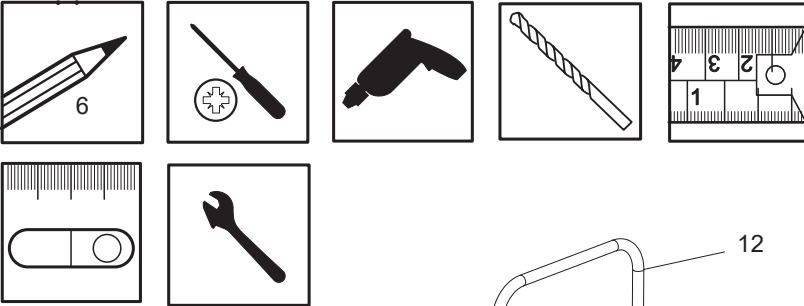

Parts Supplied

NO.	Description	Qty
1	Bar valve	1
2	Sealing washer	2
3	Flange	2
4	Adaptor	2
5	Copper olives	2
6	Wall Screw	4
7	Wall bracket	2
8	Wall plugs	4
9	Gasket	1
10	Riser rail	1
11	Shower head	1
12	Angled rail	1
13	Locking nut	1
14	Wall Screw	1
15	Hexagonal key	1
16	Fixing bracket	1
17	Wall plugs	1
18	Rail bracket	1
19	Sliding Bracket	1
20	Handset	1
21	Shower hose	1

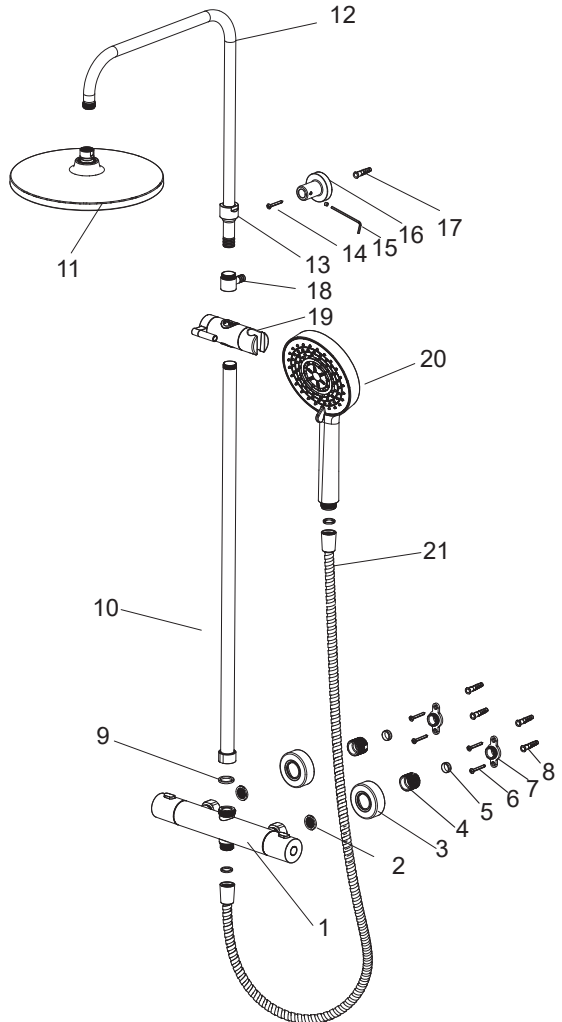

Before You Start

Hot water should be stored and distributed at a temperature of not less than 60°C which will help minimise the build-up of limescale.

For further details contact your Local Water Authority.

This shower should be installed in compliance with the UK Water(Fittings) Regulations.

- (a) Identify all components and check pack contents.
- (b) Turn off water mains supply.

Water Supply Temperature:

Hot Water Maximum: 70°C Recommended 60-65°C

Cold Water Minimum: 5°C Recommended 10-15°C

Operating Pressure Range:

Minimum: 0.5 Bar

Maximum: 5.0 Bar

Always maintain a 10°C difference between hot system temperature and maximum hot setting of valve.

Hot and Cold Maximum pressure differential should be no more than 2 bars.

If this limit is exceeded, fit a pressure reducing valve (not supplied).

Operating pressures on hot and cold water should be kept as even as possible in order to ensure the maximum efficiency of the mixer.

When water pressure is higher than 5 bar a pressure reducing valve (not supplied) must be fitted before the mixer.

Flow restrictors (not supplied) can be fitted into the wall unions to reduce water consumption a high pressure system.

Installation

-Fitting the Thermostatic Shower Valve

- 1.Flush pipe work prior to installation to remove debris from the system.
- 2.Turn off water supply following system flushing.
- 3.Mark out the position for the pipework (150mm between centres).

Note: the pipe centres required for this thermostatic bar valve are 150mm. Terminate the pipework in the wall ensuring that there is at least 26mm of 15mm diameter pipework protruding from the finished wall surface.

IMPORTANT: The water supply pipes must have the hot supply on the left and the cold supply on the right when viewed from the front.

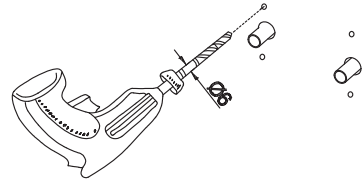
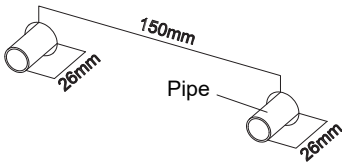

- 4.Place the wall bracket(7) over the supply pipes. Using the wall plugs(8) and wall screws(6) provided fix the wall bracket to the wall.

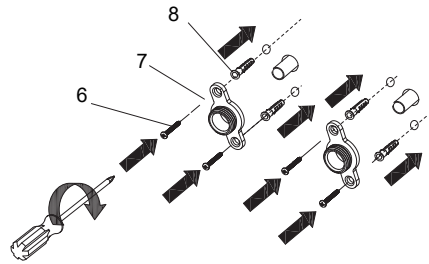

- 5.Drill suitable holes in the wall surface at the marking positions to accommodate the supply pipework and wall bracket(7). Measure and mark the fixing bracket hole for riser rail, please refer to step 1 on page 7.

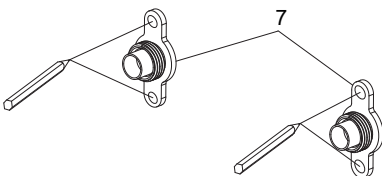

- 6.Place the copper olives(5) onto the protruding pipework.

IMPORTANT: The pipework must not protrude past the copper olives (5) by more than 7mm.

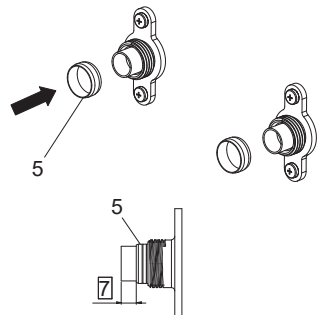

7. Holding the flat edges of the wall bracket(7) with a 48mm spanner screw the adaptors (4) onto the wall bracket(7) using a 22mm spanner. Repeat this step on both sides.

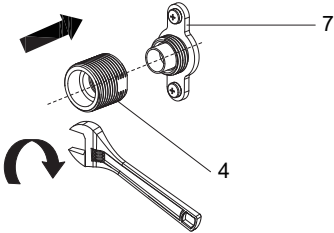

8. Screw the flange(3) over the wall bracket(7) / adaptors(4), so they are flush against the finished wall surface.

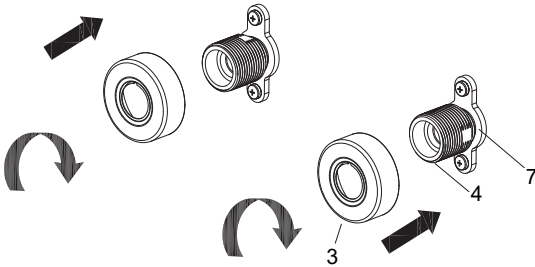

9. Place the sealing washers(2) into the bar valve fixing nuts. Position the bar valve(1) against the adaptors and carefully tighten the bar valve fixing nuts onto the adaptors. Do not over tighten.

Note: Take care not to damage the finish of the bar valve.

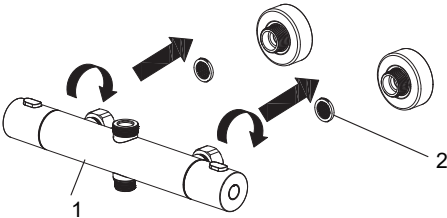

10. Turn on the water supplies and check for leaks.

-Fitting the Shower Kit

1. Using a level, measure from the central point, vertical to 731mm and mark, as shown.
2. Drill and prepare fixings for the fixing bracket using the components supplied (if suitable).
3. Insert the wall plug(17), Secure the fixing bracket(16) using the supplied wall screw (14, if suitable).use the orientation of the fixing bracket(16) and the slotted fixing to allow for minor adjustments.

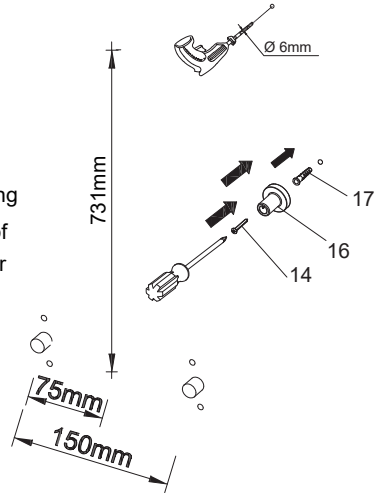

-
4. Gently press the button of the sliding bracket and push it on to the riser rail(10).

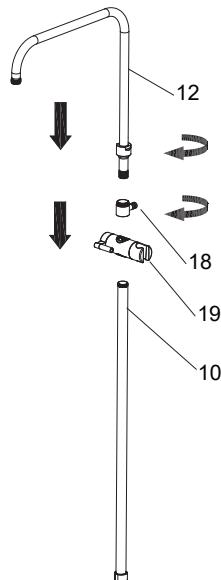

5. The height of the telescopic riser rail can be adjusted between 835-1175 mm, by loosening the clamp on the rail bracket(13), adjusting the rail bracket to the desired height(13), and re-tightening the clamp.

6. Position the riser rail(10) assembly on the bar valve outlet, tilt the riser rail(10) back and slot the rail bracket(18) into the fixing bracket(16), hold in place by gently tightening the grub screws.

Note: You can make minor adjustments by tightening or loosening.

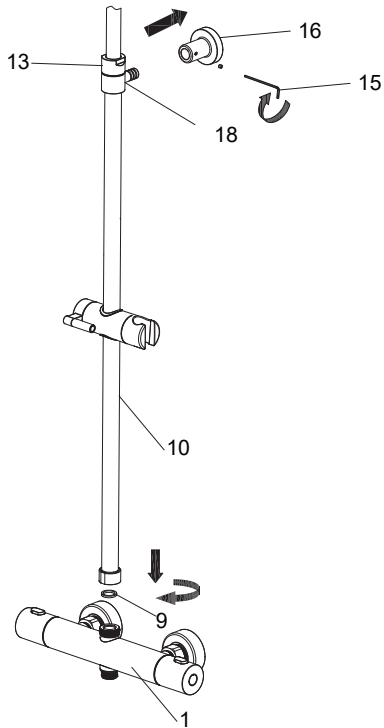

7. Tighten the fixing nuts of the riser rail using a suitable tool, taking care not to overtighten.

8. Turn on water supplies and check for leaks.

9. Ensuring the hose washer is in position, attach the non-conical end of the shower hose(21) to the bar valve. Run the shower for a few seconds to clear any debris that may be present. Then attach the conical end of the shower hose(21) to the handset(20), then place the hose in the sliding bracket.

10. Ensure the hose washer is in place, screw the shower head(11) onto the arm, taking care not to damage the plated surface. Tighten carefully using a suitable tool taking care not overtighten.

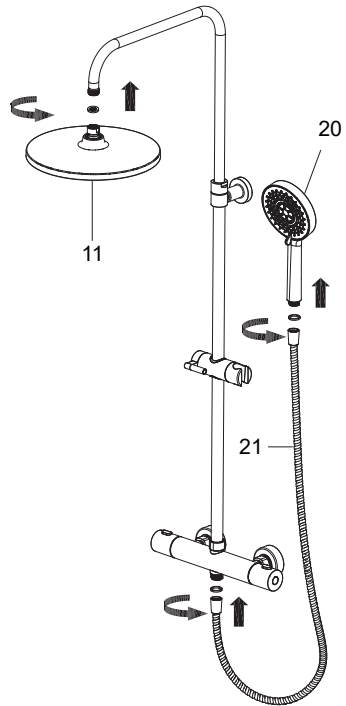

Temperature Setting(To be done only when essential)

This mixer has been set in the factory under balanced pressures and hot water supply at 65°C.

When your operating conditions vary significantly from the above, the temperature of the mixed water may vary from the setting. In this case, you can set the temperature of the mixer to suit your requirements.

The valve is set to a maximum 44°C. This can be checked if required using a thermometer. If this temperature is incorrect, you can reset it as follows:

1. Turn the handle to 38°C position.
2. Remove handle cap, then the handle screw, then the temperature handle.
3. Without removing the black stop,turn the spindle of thermostatic valve until the temperature is at the required level.
4. Test again using a thermometer.
5. When the required temperature is reached, re-fit the components, so that the chrome button stop will be at your new set temperature.

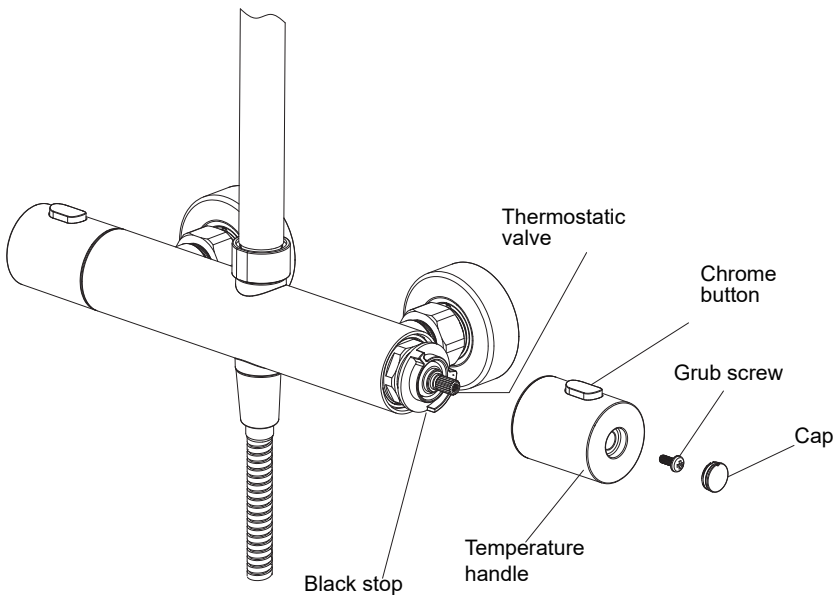

Aftercare

Cleaning the thermostatic cartridge

1. Before carrying out any maintenance, turn off the mains water supply. If you are unsure contact a qualified plumber.
2. Remove the cap, grub screw, temperature handle.
3. Pull the black stop from the cartridge. Remove the retaining nut using a suitable spanner, remove and clean the thermostatic cartridge rinse thoroughly under cold water to remove any build up of limescale or debris.

Note: take note of the position of the black stop cartridge, it must be re-fitted in the same position.

4. Replace the cartridge into the body, tighten the retaining nut using a suitable spanner.
5. Re-fit the black stop, temperature handle, tighten the grub screw and re-fit cap to handle.

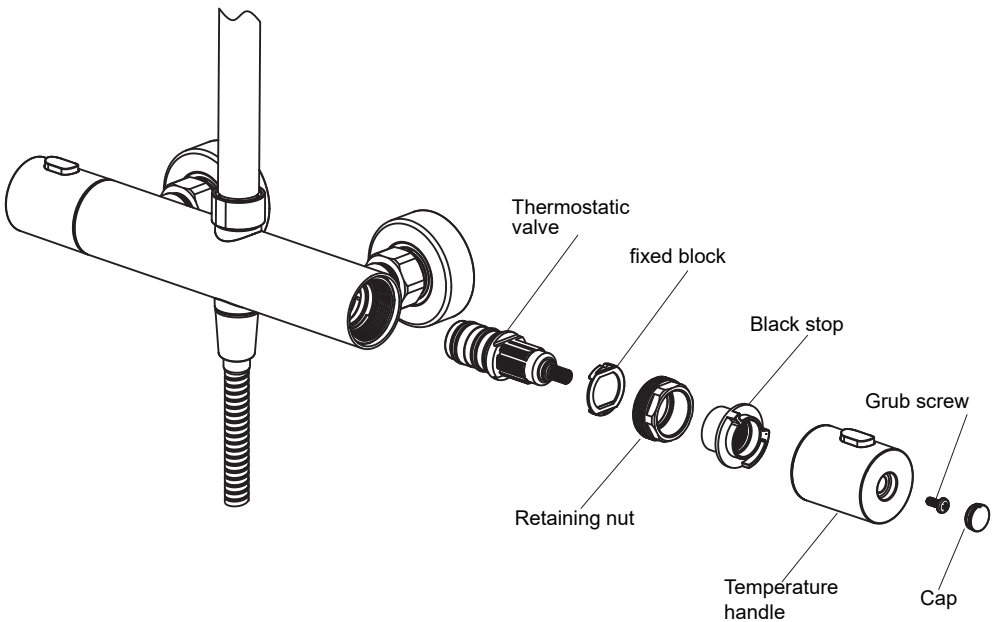

Cleaning the flow cartridge

1. Before carrying out any maintenance, turn off the mains water supply.
If you are unsure contact a qualified plumber.
2. Remove the cap, grub screw, flow handle, rinse
3. Remove the retaining nut using a suitable spanner, clean the diverter thoroughly under cold water to remove any build up of limescale or debris.
4. If necessary replace the diverter.
5. Re-fit the diverter into the body, tighten the retaining nut using a suitable spanner.
6. Re-fit the flow handle, tighten the grub screw and re-fit cap to handle.

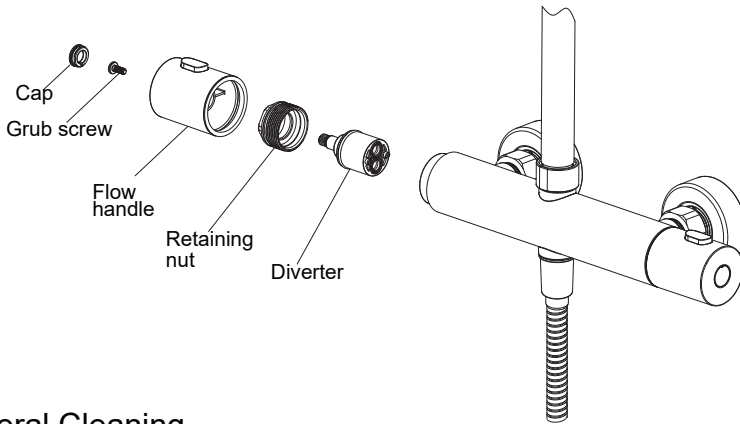

General Cleaning

Whilst modern plating techniques are used in the manufacture of these fittings, the plating will wear if not cleaned properly. The safest way to clean your product is to wipe with a soft damp cloth. Stains can be removed using washing up liquid. Do not use aggressive cleaning products or polishes or those which contain bleach, acids or alcohol as this may damage the surface of the product.

Guarantee terms:

In the unlikely event that this product does not meet your expectations or a quality issue arises, please contact your point of purchase with the details and your proof of purchase. We reserve the right to carry out a product inspection prior to validating a claim. The product carries a 5 year guarantee which covers against manufacturing defects. Replacement parts which are subject to wear and tear (e.g. cartridges, sliders) are covered at the discretion of the retailer. The guarantee does not cover deterioration through normal wear and tear, deterioration due to infestation, wilful damage, accident, improper or negligent use, unauthorised modification or repair, or incorrect storage. During the guarantee period for the product, we will, at our discretion, repair or replace the product, or the defective part, subject to the repair or replace the product, or the defective part, subject to the guarantee exclusions set out above and your claim being validated.

Troubleshooting

Issue	Cause	Remedy
No flow or low flow rate and /or varying temperatures.	Check showerhead, hose and filters for any blockage.	Clean as necessary. Refer to Aftercare section (page 10-11).
	Partially closed stop or service valve in water supply pipework to the shower valve.	Open stop or service valve.
	Instantaneous water heater cycles on and off as the flow rate or pressure is too low.	Increase water flow rate or pressure system. Contact the boiler manufacturer.
	Head of water is below the minimum distance required.	Raise the cistern or fit a shower booster pump.
	Inlet filter is partially blocked.	Clean or replace, flush through pipework before refitting.
	Hot or cold water being drawn off elsewhere causing pressure changes or instantaneous boiler temperature changes.	Do not use other water outlets when using the shower.
	Make sure the maintained inlet pressures are nominally balanced and sufficient.	Refer to Water Supply Temperature (page 4).
	Airlock or partial blockage of the pipework.	Flush through pipework to ensure removal of debris and any airlocks.
	No hot or cold water reaching the shower valve.	Check hot and cold feeds (the valve will shut down if either the hot or cold supply fails).
Only hot or cold water from the shower valve outlet.	Partially closed stop or service valve in water supply pipework to the shower valve.	Open stop or service valve.
	Inlet filter is partially blocked.	Clean or replace, flush through pipework before refitting.
	Inlet water supplies are reversed (hot to cold supply).	Check the connections are the correct way round. Hot on the left and cold on the right when viewed from the front. Rework pipework as necessary.
Water leaking from showerhead.	This is normal for a short time after turning off.	Adjust angle of showerhead in holder as necessary to vary draining time.
	Shower flow valve failing to close fully, possibly due to water borne debris.	Remove flow valve and check. Refer to Aftercare section (page 10-11) before dismantling shower valve.
Maximum water temperature too hot or cold.	Maximum water temperature set incorrectly.	Reset maximum water temperature. Refer to Temperature setting (page 9).
Outlet water temperature too hot / cold.	Inlet filter is partially blocked.	Check inlet filters for any blockages and clean as necessary.
	Installation conditions outside operating parameters.	Refer to Water Supply Temperature (page 4). Refer to Aftercare section (page 10-11). Refer to Temperature setting (page 9).
Water temperature too cold Maximum water temperature incorrectly set.	Hot water temperature is less than 10°C above the required blend temperature.	Adjust hot water temperature or wait for water to reheat if stored system is used.
	Instantaneous water heater not igniting because water flow rate is too low.	Increase water flow rate through the system. Check inlet filters and clean or replace. Refer to Aftercare section (page 10-11). Contact the boiler manufacturer.