

N 90, INDUCTION HOB WITH INTEGRATED VENTILATION SYSTEM, 80 CM, SURFACE MOUNT WITH FRAME
V68AUX4C0

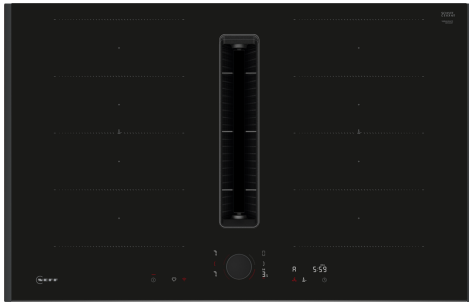

B



Included accessories

1 x Slider for unducted recirculation, 1 x Clean Air Plus odor filter

Optional accessories

Z861SI1 90° Adapter round-flat, Z861SM1 Straight tube 500mm, Z861SM2 Straight tube 1000mm, Z861SS1 Connector sleeve (female), Z861SS2 Flex sleeve (female), Z9401FF0 Flex Pan, large, Z9401TY0 Teppan Yaki, Z9403FF0 Flex Pan set, 3 pcs., Z9404FF0 Flex Pan set, 4 pcs., Z9404SE0 4 pieces Set, Z9406SE0 6 pieces Set, Z9410ES0 Espresso maker 4 cups, Z9410X1 Stainless Steel roaster with glas lid, Z9415X1 Steaming Rack for Stainless Steel roaste, Z9416X2 Griddle Plate, Z9417X2 Teppan Yaki (large), Z9428FE0 Iron pan Ø 18 / 28 cm, Z943SE0 Set of 2 pots and 1 pan, Z811DU0 Acoustics Filter, Z821PD1 Plinth Diffusor, Z821VR1 Clean Air Plus odor filter (replacement), Z861KE1 Exhaust kit, Z861KR0 Recirculation kit 2 L-bow (70cm), Z861KR1 Recirculation kit S and L-bow (60cm), Z861KR2 Recirculation kit 1x L-bow, Z861SB1 90° flat duct bend horizontal, Z861SB2 90° flat duct L vertical, Z861SB3 90° flat duct M vertical, Z861SB4 90° flat duct S vertical, Z861SI0 Adapter round-flat

This induction hob with integrated ventilation combines two appliances in one for a clear view while cooking.

- ✓ Twist Pad®: the removable, magnetic control dial for precise, convenient control.
- ✓ Flex Induction: flexible cooking zones and automatic cookware detection.
- ✓ Intuitive Flex Zones: place your cookware. And the size, shape and position are instantly detected.
- ✓ Automatic Air Sensor – Constantly adjusts the extraction rate to match the situation in the kitchen.
- ✓ High Extraction Rate – ensures a clear view while cooking thanks to efficient motor technology.

Features

Technical Data

Product name/family: Cooking zone ceramic
 Built-in / Free-standing: Built-in
 Energy input: Electric
 Min. required niche size for installation (HxWxD): 223 x 750-750 x 490-500 mm
 Width of the appliance: 834 mm
 Dimensions: 223 x 834 x 527 mm
 Dimensions of the packed product (HxWxD): . 420 x 950 x 670 mm
 Net weight: 24.1 kg
 Gross weight: 30.5 kg
 Residual heat indicator: Separate
 Location of control panel: Front
 Basic surface material: Ceramic
 Color of surface: Black
 Length electrical supply cord: 110.0 cm
 Sealed Burners: No
 heating with booster: All
 Power of 2nd heating element (kW): 3.3 kW
 Maximum output air extraction: 500 m³/h
 Boost position output recirculating: 595.0 m³/h
 Maximum output recirculating air: 499 m³/h
 Boost position air extraction: 622 m³/h
 Noise level: 69 dB(A) re 1 pW
 Odour filter: No
 Voltage: 220-240/380-415 V
 Frequency: 50-60 Hz
 Length electrical supply cord: 110.0 cm
 Min. required niche size for installation (HxWxD): 223 x 750-750 x 490-500 mm
 Dimensions: 223 x 834 x 527 mm
 Dimensions of the packed product (HxWxD): . 420 x 950 x 670 mm
 Net weight: 24.1 kg
 Gross weight: 30.5 kg
 Included accessories: 1 x Slider for unducted recirculation, 1 x Clean Air Plus odor filter
 Delay Shut off modes: 30R_12E min



N 90, INDUCTION HOB WITH INTEGRATED VENTILATION SYSTEM, 80 CM, SURFACE MOUNT WITH FRAME V68AUX4C0

Features

- 80 cm: space for 4 pots or pans.

Flexibility of cooking zones

- 2 Flex zones: use cookware of any shape or size anywhere within the 40cm long zone.
- Cooking zone front left: 200 mm, 230 mm, 2.2 KW (max. power 3.7 KW)
- Cooking zone rear left: 200 mm, 230 mm, 2.2 KW (max. power 3.7 KW)
- Cooking zone rear right: 200 mm, 230 mm, 2.2 KW (max power 3.7 KW)
- Cooking zone front right: 200 mm, 230 mm, 2.2 KW (max. power 3.7 KW)

Usage convenience

- Light Dialog with two coloured display (white/red): see directly, which cooking zone is heating and which function is in use on the two-coloured display.
- yes: directly access favourite functions with a configurable button (available with connected Home Connect account).
- Variable 17-stage power settings for each zone: precisely adapt the heat with 17 power levels (9 main levels and 8 intermediate levels).
- Switch-off timer: switches off the cooking zone at the end of the time set (e.g. for boiled eggs).
- alternative: an alarm sounds at the end of the time set (e.g. for pasta).
- Sound volume adaptable to personal preference and needs.

Time saving & efficiency

- Power Boost function for all zones
- : boil water faster thanks to 50% more energy than at the highest standard level.
- Cooking zones will be automatically joined or separated based on the shape and size of the cookware placed.
- PowerTransfer: when moving a pot to a different cooking zone, this feature transfers all previous settings to the new zone at the touch of a button.
- when moving a pot, the settings adjust instantly and the cooking zone adapts to the size of the cookware
- yes: when switched on, the hob automatically selects the cooking zone on which a new cookware is placed. yes: when switched on, the hob automatically selects the cooking zone on which a new cookware is placed.
- QuickStart function: when switching on, the hob automatically selects the cooking zone with cookware (when placed on a zone whilst the hob is off).
- ReStart function: in case of unintentional switch-off, this feature restores all previous settings by switching on the hob again within 4 seconds.

Cooking assistance

- 11 frying levels: prevents overcooking with the automatic temperature regulation of the integrated sensor.
- Dish assistant: easily find the right temperature setting for a certain

dish via the home connect app.

Connectivity

- Home Connect with Remote Monitoring: check if the hob is switched off even when not at home, and find recipes or additional functions in the Home Connect app.
- via MyButton: open up the smart universe from your cooktop (partner service required). via MyButton: open up the smart universe from your cooktop (partner service required).
- Updateable appliance (available with connected Home Connect account): keep appliance always up to date with latest status of software. Updateable appliance (available with connected Home Connect account): keep appliance always up to date with latest status of software.

Design

- Neff Collection exclusive zone printing: minimalistic design thanks to dark colour of zone printing. Neff Collection exclusive zone printing: minimalistic design thanks to dark colour of zone printing.

Safety

- 2 stage residual heat indicators: indicates which cooking zones are still hot or warm.
- Control panel lock: prevent unintended activation of the hob.
- Main switch: switch off all cooking zones at the touch of a button.
- Safety cut out facility: for safety reasons, heating stops after a preset time if not used (possible to customise).

Installation

- Dimensions of the product (HxWxD mm): 223 x 834 x 527
- Required niche size for installation (HxWxD mm) : 223 x 750 x (490 - 500)
- Min. worktop thickness: 16 mm
- Connected load: 7.4 KW
- 4.6kW power output (20A); current management options for 16A, 13A or 10A connection: limit the maximum power if needed (depends on fuse protection of electric installation).
- Power cord: 1.1 m, Cable included in packaging

Accessories

- Clean Air Plus odor filter, Slider for unducted recirculation included
- Suitable for installation into a 60 cm base cabinet

Integrated ventilation downdraft system

- Induction cooktop with fully integrated high-performance downdraft extractor.
- Suitable for ducted or recirculated extraction configuration (incl. differentiated software modes). Installation accessories for unducted recirculation, among these four cleanAir odor filters and a telescopic slider element, are included in the cooktop. Accessories for other installation options are available, details in the planning notes.
- Aesthetically integrated fully flush air intake design with floating, heat resistant glass ceramics element for free movement and placement of cookware.

Features

- - Automatic switch-on of ventilation system when a cooking zone is used.
- - Sensor-based and cooktop-based, fully-automatic adjustment of power levels via advanced algorithm for maximum convenience.
- - 3 possible sensitivity modes of algorithm for maximum convenience (Low-noise oriented, balanced, performance-oriented).
- - Automatic delayed shut-off after cooking to erase residual odors after cooking (in specific ultra low-noise fan level, 12min in ducted extraction, 30min in recirculated extraction, can be shut-off manually).
- - High-performance, low-noise blower with energy-efficient BLDC-technology. High extraction rates at very low noises with pleasant noise frequencies through psycho-acoustically and aerodynamically optimized interior with enclosed, non-visible blower. Highly pressuredrop resistant even with longer and more complex ductings.
- - Easy-to-detach and easy-to-clean grease filter and liquid collector unit:
- - Convenient one-hand removal of unit via floating glass ceramics handle.
- - Integrated, large-scale, high performance stainless-steel grease filters with 12 filtration layers and one black top layer for enhanced aesthetical integration. Grease filtration efficiency of 94 %.
- - All parts of the unit are easy-to-clean, fully dishwasher safe and heat resistant.
- - (Upper) Liquid collector unit with 200ml of capacity for standard accidental spillages or cooking condensate.
- - Powerful drainage system for spillages that exceed 200ml of liquids.
- - Liquid safety collector with additional capacity of 700ml for more severe accidental situations. Dishwasher safe. Easily accessible and detachable from below.
- - Overall capturing capacity of 900ml (200ml + 700ml).
- - Watertight blower system.
- - Ventilation system performance:
- - Extraction performance in ducted extraction (according to EN 61591): min. normal setting 154 m³/h , max. normal setting 500 m³/h , max. Boost-/Intensive setting 622 m³/h .
- - Extraction performance in recirculated extraction (according to EN 61591): min. normal setting 132 m³/h , max. normal setting 499 m³/h , max. Boost-/Intensive setting 595 m³/h.
- - Noise level in ducted extraction (Sound power level according to EN 60704-3): min. normal setting 42 dB re 1 pW, max. normal setting 69 dB re 1 pW, max. Boost-/Intensive setting 74 dB re 1 pW.
- - Noise level in recirculated extraction (Sound power level according to EN 60704-3.): min. normal setting 41 dB re 1 pW, max. normal setting 68 dB re 1 pW, max. Boost-/Intensive setting 72 dB re 1 pW.
- - Grease filter efficiency (according to EN 61591) 94 %.
- - Consumption data and energy efficiency (according to Regulation (EU) No 65/2014):
- - Energy Efficiency Class: B (at a range of energy efficiency classes from A+++ to D).
- - Fluid Dynamic Efficiency: A .
- - Average energy consumption: 57 .
- - Grease filtration efficiency class: B .
- - Noise min. normal setting & max. normal setting: 42 dB & 69 dB .

- For recirculation configuration: 2 x 2 battery of directly integrated, high-performance cleanAir odor filters.
- - Optimised odour reduction performance for cooking applications with complex odour molecules (e.g. fish).
- - Large scale filter surface with high odour reduction capabilities.
- - Anti-pollen functionality: The filter retains an extremely high amount of airborne pollen and deactivates allergens which are retained by the filter.
- - Lifetime of 360 hours of cooking (non-regenerative).
- - Low-noise filters with optimised psycho-acoustics.
- - Easy-to-access and easy-to-remove from above.
- - Replenishment cleanAir filter set Z821VR0.
- For ducted extraction configuration: 2 x 2 sets of directly integrated, high-performance low-noise acoustic filters for significantly lower noise and improved psycho-acoustics.

Planning & installation notes

- Suitable for ducted or recirculated extraction installations in 4 different options (unducted, partly and fully ducted recirculation or ducted extraction). Installation accessories for unducted recirculation, among these four cleanAir odor filters and a telescopic slider element, are included in the cooktop. The included accessories allow easy and quick installations and can be planned in all worktop depths ≥60cm. For other types of installation, one of the following accessory kits is recommended:
- Z861KR1 for partly-ducted recirculation in worktops of ≥60cm depth with max. worktop height of 960 mm. Z861KR0 for partly-ducted recirculation in worktops of 70cm depth of ≥70cm depth with max. worktop height of 960 mm.
- Z861KE1 as starter kit for ducted extraction in worktops of ≥60cm depth.
- To complete the fully ducted extraction or to do any other individual recirculation planning different ducting accessories are available.
- Planning suggestions:
- - Installation is possible in island as well as wall oriented configurations.
- The product and its accessories comply with the Needle Flame Test (according to IEC 60695-11-5) and the V2 flammability class (according to UL94).
- - The max. immersion depth is 223 mm below worktop surface.
- - The appliance must be freely accessible from below (i.e. for accessing the lower liquid safety collector).
- - No false floor is necessary below the cooktop with integrated downdraft ventilation system. The drawers and/or shelves in the floor unit must be removable. The backpanel of the floor unit can be kept - only a cut-out for the air outlet is needed (position and size can be taken from the installation instructions).
- An installation with unducted recirculation requires a vertical aperture of min. 25mm behind the backpanel of the furniture. Suggested for ideal performance are 50mm.
- The minimum worktop thickness is 16 mm for top mounted and flush installed appliances with the standard installation system. Installation in even thinner worktops is also possible with the spare part: content 626792.
- - The overall appliance weight is 26kg - the bearing capacity and stability, in the case of very thin worktops in particular, must be supported using suitable substructures. The overall appliance weight and the worktop manufacturer's structural integrity specifications are to be taken into account.
- - For partly ducted and unducted recirculation extraction

Features

installations, a return-flow aperture of $\geq 400\text{cm}^2$ is to be respected in the plinth area. The aperture can be realized via outlet grids, lamella grids or subtly shortened plinths depending on the assortment of the kitchen furniture manufacturer.

- - The air outlet on the backside of the appliance can directly be accessed with a male flat duct element (DN 150).
- - The pressuredrop resistant blower allows longer and more complex ductings up to 8m with three 90° bows while keeping sufficient performance.
- - When installing a ventilation hood with ducted extraction and a chimney-vented fireplace, the power supply line of the appliance needs a suitable safety switch. This is not required for configurations in recirculated extraction.
- - In ducted extraction configuration a one-way flap (or backflow trap) with a maximum opening pressure of 65Pa should be installed.

N 90, INDUCTION HOB WITH INTEGRATED VENTILATION SYSTEM, 80 CM, SURFACE MOUNT WITH FRAME V68AUX4C0

Dimensioned drawings

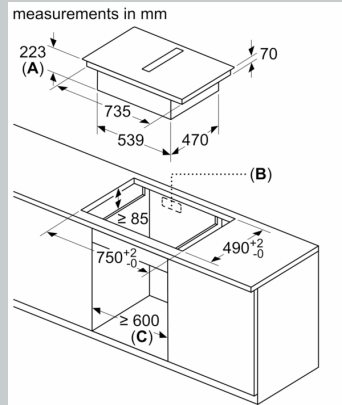
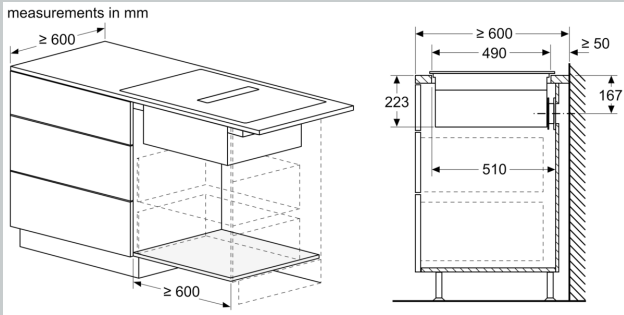

- A: Recess depth
- B: Cut-out in back panel required for pipework. Exact size and position can be taken from specific drawing.
- C: All 80 cm width class models can be installed in 60 cm wide furniture by adjusting the side panels.

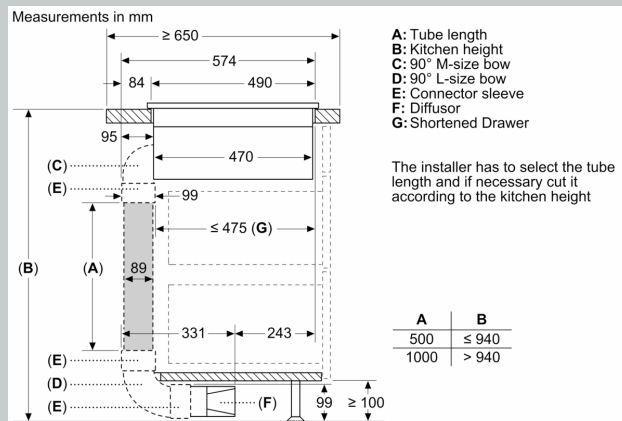
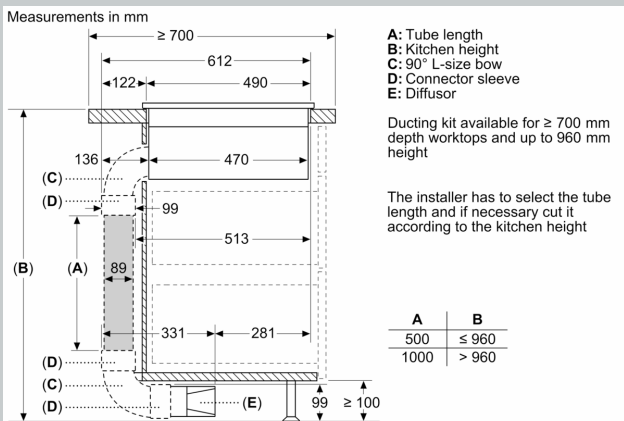

Dimensioned drawings

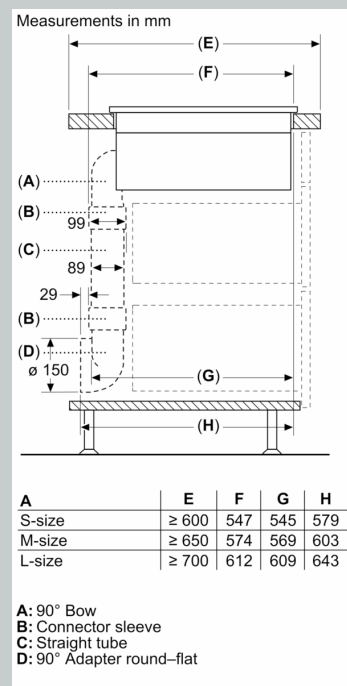
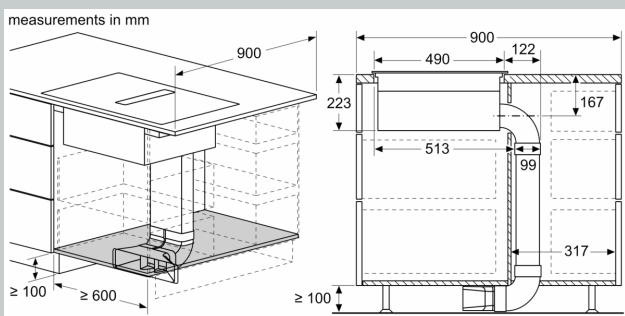
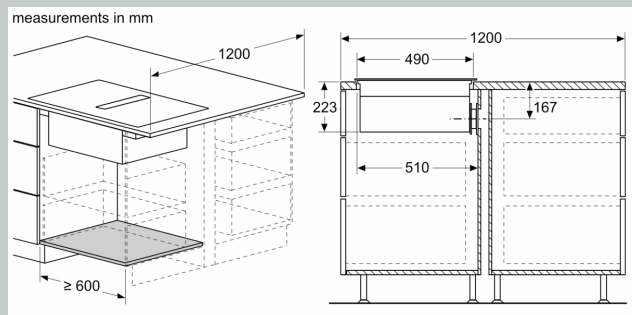
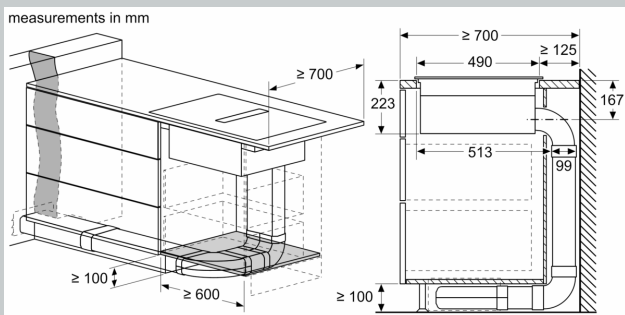
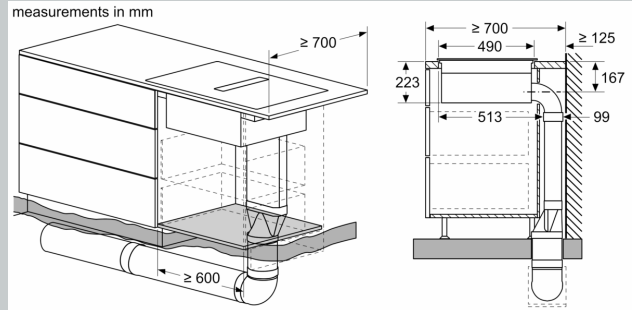
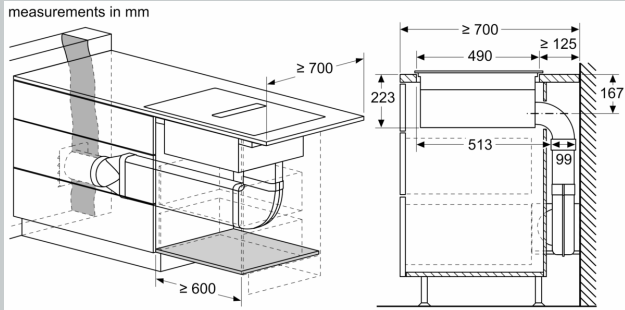

Dimensioned drawings

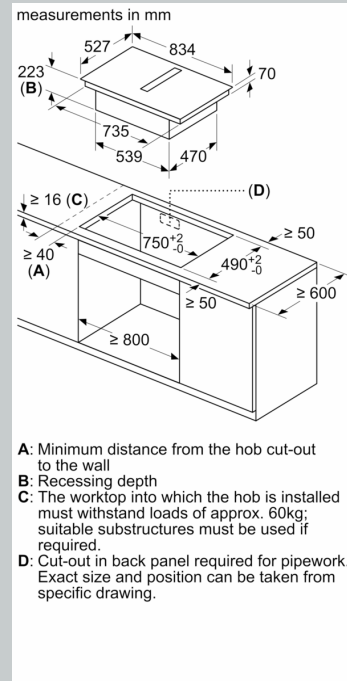
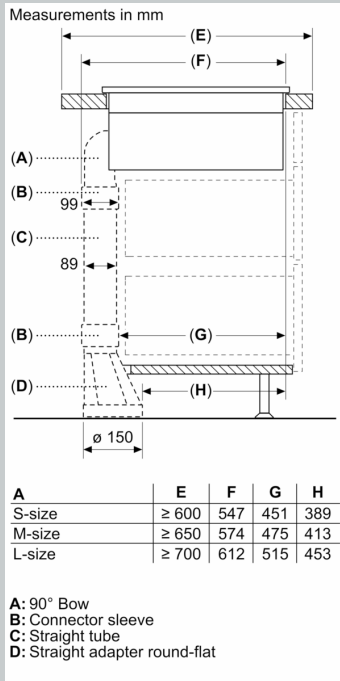

Measurements in mm

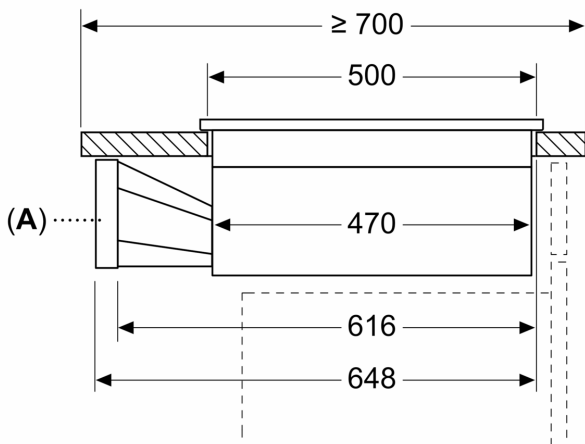

measurements in mm
Front view

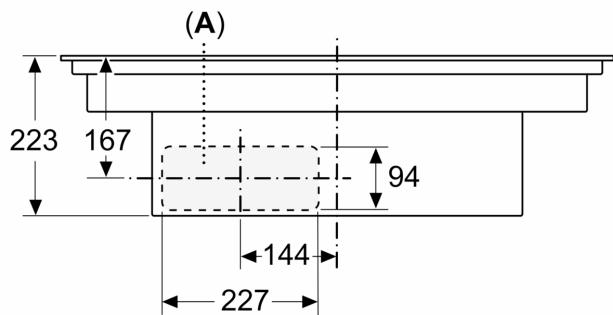

Dimensioned drawings

measurements in mm
Front view - unit cut-out
for unducted recirculation

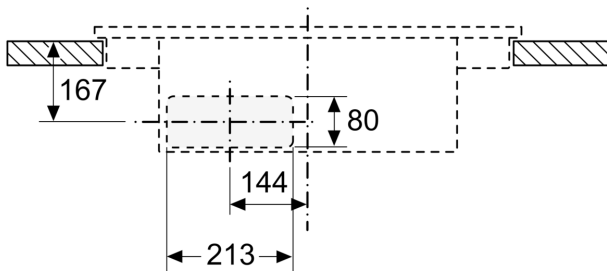

measurements in mm

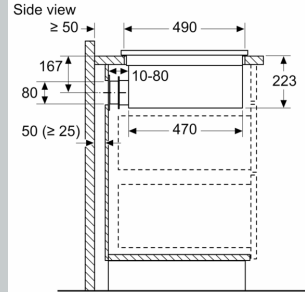

When installing directly against outer walls that are not insulated ($\mu \geq 0.5 \text{ W/m}^2 \cdot \text{C}$), we recommend using partially or fully ducted recirculation configurations.

measurements in mm
Front view

