

N 90, DOWNDRAFT HOOD, 80 CM, CLEAR GLASS
188WMM1S7B

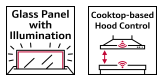

A



The Glass Draft Hood seamlessly integrates into the kitchen, with ability to install behind the hob for a single surface look and clear glass panel when in use. Powered by new Guided Air technology for effective extraction, and Climate Control Sensor to optimise the power and noise levels as you cook.

- ✓ Guided Air Technology – Equally powerful steam extraction all over the cooktop regardless of the pans' or pots' location
- ✓ Glass Panel with Illumination – 25 million colour options for inspiring illumination of your cooktop
- ✓ Easy Access Filter – A simple push of a button is enough to remove the easy access filter for a good wash in the dishwasher
- ✓ High Extraction Rate – ensures a clear view while cooking thanks to an efficient motor technology
- ✓ Cooktop-based Hood Control – Adjust your hood 's extraction level and lighting.

Optional accessories

Z861SM2 Straight tube 1000mm, Z861SS1 Connector sleeve (female), Z92WWB1X6 Clean Air Plus odor filter (replacement), Z92WW1X6 Clean Air Plus recirculation kit, Z861SB1 90° flat duct bend horizontal, Z861SB2 90° flat duct L vertical, Z861SI0 Adapter round-flat, Z861SI1 90° Adapter round-flat, Z861SM1 Straight tube 500mm, Z92WWJ11 Long Life recirculation kit, Z92WWM11 Installation kit remote motor, Z92WWY8X2 Mounting kit for seamless installation, Z93WWX1X1 Flat duct adapt.round 90° DN150 Metal, Z93XXX1X1 Aluflex pipe cyl. 150

Features

Technical Data

Typology: Downdraft
 Length of electrical supply cord: 130.0 cm
 Min. required niche size for installation (HxWxD): 703mm x 781.0mm x 123mm mm
 Net weight: 37.0 kg
 Type of control: Electronic
 Number of speed settings: 3-stage + 2 intensive
 Maximum output air extraction: 501 m³/h
 Boost position output recirculating: 525 m³/h
 Maximum output recirculating air: 416 m³/h
 Boost position air extraction: 775 m³/h
 Maximum Air flow: 501 m³/h
 Noise level: 62 dB(A) re 1 pW
 Diameter of air outlet: 150 mm
 Grease filter material: Washable stainless steel
 EAN code: 4242004252306
 Connection rating: 300 W
 Fuse protection: 10 A
 Voltage: 220-240 V
 Frequency: 60; 50 Hz
 Plug type: GB plug
 Installation type: Built-in
 Delay Shut off modes: 10 min



N 90, DOWNDRAFT HOOD, 80 CM, CLEAR GLASS 188WMM1S7B

Features

Connectivity

- Remote Monitoring and Control for connected home appliances and operation via smartphone or tablet (only in countries where Home Connect service is available)
- The Home Connect functionality can be extended by integrating numerous applications from external cooperation partners (partnerships)
- Voice Control enabled via popular voice assistants (only in countries where this service is available)
- Interval function: available via Home Connect
- Silence function: available via Home Connect

Variant

- 80 cm wide
- Energy Efficiency Class: A (at a range of energy efficiency classes from A+++ to D)
- Extraction rate exhaust air according to EN 61591:
 - max. normal use 501 m³/h, intensive 775 m³/h
- Noise level according to EN 60704-3 and EN 60704-2-13 at max. normal use exhaust air: 62 dB(A) re 1 pW

Features

- Fully automatic hood
- Hob-Hood control (with Wi-Fi enabled hob)
- climateControl Sensor
- Additional functions: Ambient light RGB
- 3 power levels and 2 intensive settings
- Touch control
- The standard functions are located on the right-hand user interface
- Efficient BLDC technology
- Automatic intensive revert (6mins)
- Automatic after running (Automatic after running (10 minutes))
- 2 metal grease filter cassettes
- Saturation indicator for metal and charcoal filter
- The filter service button automatically lifts filters into service position for easy removal

Design

- Extendable clear glass panel with edge lighting
- The glass panel can be easily removed and cleaned
- Installation: integrated
- Suitable for installation in an island or Semi-island kitchen solution

Performance

- Suitable for ducted extraction and recirculation
- For recirculated extraction Clean Air Plus recirculation kit (accessory) needed
- Maximum extraction rate exhaust air 501 m³/h according to EN 61591
- Extraction rate according to EN 61591 ø 15 cm:
 - max. Normal use 501 m³/h
 - Intensive 775 m³/h
- Noise level according to EN 60704-3 and EN 60704-2-13 exhaust air:

- Max. normal use: 62 dB(A) re 1 pW
- Intensive: 70 dB(A) re 1 pW
- Noise max. Normal Level: Noise, max. speed in normal use: 62 dB dB*
- With the Clean Air Plus recirculation kit (available as optional accessory) your appliances reaches:
 - Extraction rate in recirculation mode: Max. normal use: 416 m³/h
 - Intensive: 525 m³/h
 - Noise level in recirculation mode: Max. normal use: 65 dB(A) re 1 pW
 - Intensive: 70 dB(A) re 1 pW
 - Average Energy Consumption: 36.9 kWh/year*
 - Blower Efficiency Class: A*
 - Lighting Efficiency Class: -*
 - Grease Filtering Efficiency Class: B*
 - Power rating: 300 W

Planning and installation information

- Not suitable for combination with gas hobs
- Extension height 250 mm
- Dimensions (HxWxD): 709 x 802 x 140 mm
- Built-in dimensions (HxWxD): 703 x 781 x 123 mm
- Extractor hose 150 mm
- Electrical cable length 1.3 m
- Please reference the built-in dimensions provided in the installation drawings

* In accordance with the EU-Regulation No 65/2014

N 90, DOWNDRAFT HOOD, 80 CM, CLEAR GLASS
188WMM1S7B

Dimensioned drawings

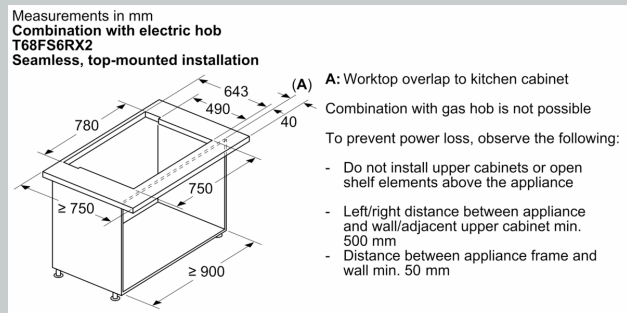
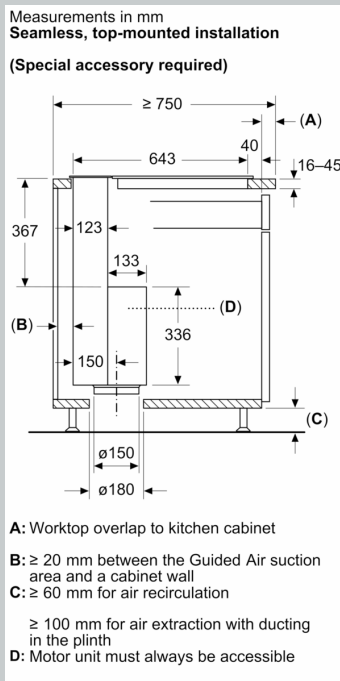
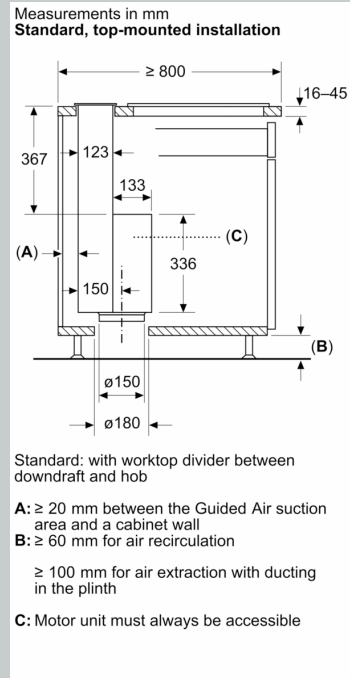
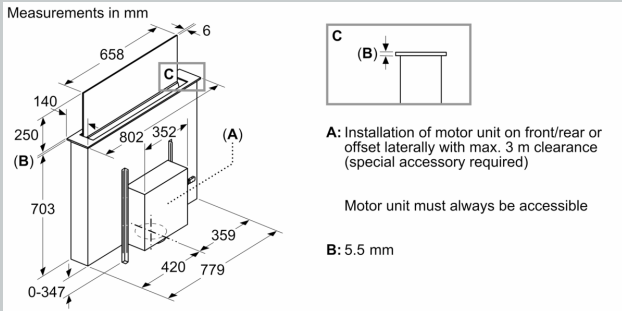

Dimensioned drawings

Measurements in mm Combination with electric hob Standard, top-mounted installation

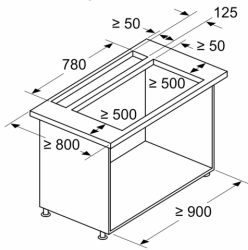

Standard: with worktop divider between downdraft and hob

Combination with gas hob is not possible

To prevent power loss, observe the following:

- Do not install upper cabinets or open shelf elements above the appliance
- Left/right distance between appliance and wall/adjacent upper cabinet min. 500 mm
- Distance between appliance frame and wall min. 50 mm

Planning recommendation, air recirculation

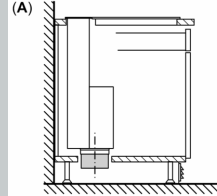

A: Exterior wall – U-value $\leq 0.5 \text{ W}/(\text{m}^2\text{K})$

Standard installation: Partially laid around the toe kick

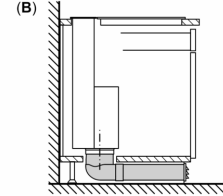

B: Exterior wall – U-value $> 0.5 \text{ W}/(\text{m}^2\text{K})$

Installation with fully laid pipework to the toe kick for poorly insulated exterior walls or above cold floors

Measurements in mm Combination with electric hob Seamless, top-mounted installation

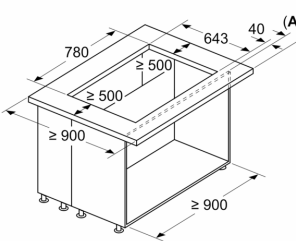

A: Worktop overlap to kitchen cabinet

Combination with gas hob is not possible

To prevent power loss, observe the following:

- Do not install upper cabinets or open shelf elements above the appliance
- Left/right distance between appliance and wall/adjacent upper cabinet min. 500 mm

Measurements in mm Combination with electric hob Standard, top-mounted installation

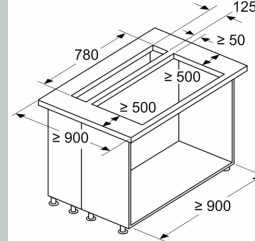

Standard: with worktop divider between downdraft and hob

Combination with gas hob is not possible

To prevent power loss, observe the following:

- Do not install upper cabinets or open shelf elements above the appliance
- Left/right distance between appliance and wall/adjacent upper cabinet min. 500 mm

Measurements in mm Standard, top-mounted installation

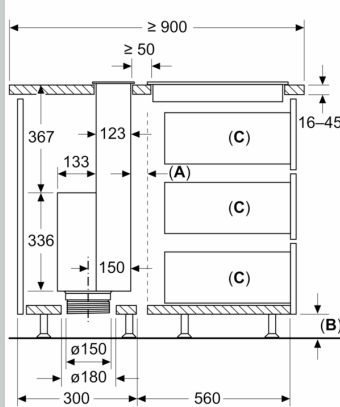

Standard: with worktop divider between downdraft and hob

A: Ventilation gap for hob

B: $\geq 60 \text{ mm}$ for air recirculation

$\geq 100 \text{ mm}$ for air extraction with ducting in the plinth

C: Max. pull-out depth

Motor unit must always be accessible

Measurements in mm Seamless, top-mounted installation

(Special accessory required)

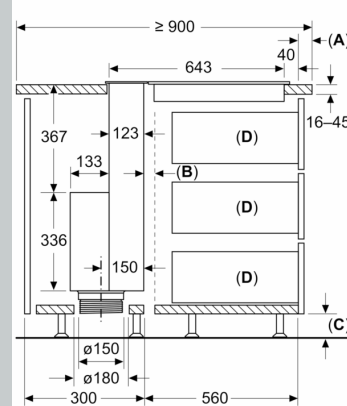

A: Worktop overlap to kitchen cabinet

B: Ventilation gap for hob

C: $\geq 60 \text{ mm}$ for air recirculation

$\geq 100 \text{ mm}$ for air extraction with ducting in the plinth

D: Max. pull-out depth

Motor unit must always be accessible