

EN Bathroom Furniture User's Guide

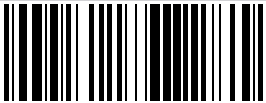

6901397

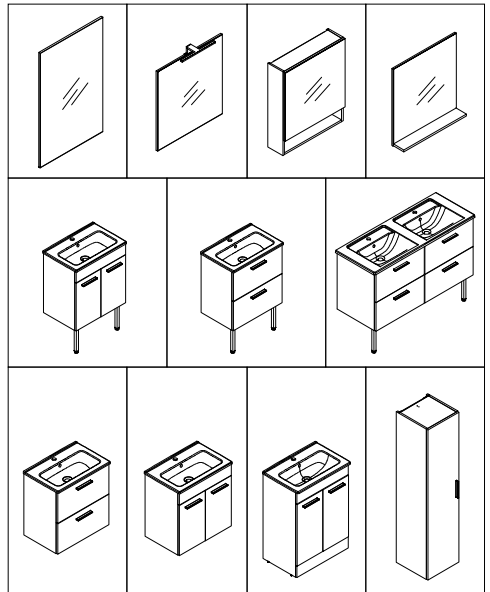

Bathroom Furniture User's Guide

Dear customers,

By ensuring a correct and purposeful use of this product which you have purchased, we would like it to deliver the best performance to you.

- 1- Accept the purchased product by removing it from its carton at our sales point and/or at the delivery to address and checking its parts one by one. If any missing materials or any breakage or damage is detected, inform the nearest Authorized Seller or the Authorized Service. In such cases, please protect the product in its original packaging.
- 2- Have the User Manual of the product which you have received without any missing parts or any damages APPROVED by the Authorized Seller.
- 3- We urge you to carefully read this guide in full before having our product installed and keep it for future reference.
- 4- Please call the Authorized Service after completing the preparations for the required infrastructure.
- 5- In the event you need service for installation, maintenance and repairs;
 - Ask from our seller for the telephone number of the Authorized Service in the area you are living in.
 - In places where we do not have a seller, you may get the necessary information from the telephone numbers given in the guide
 - Ask the service personnel to display their "Authorized Service Personnel Card". Do not let people without a personnel card perform the installation
 - At the completion of the process, the technician is obliged to write the 'Service Form' correctly and in detail and have you sign it and give a copy to you. Please keep the 'Service Form'.
 - The items above have great importance for determining people who work under the name of special service and who are not Authorized Services. Please take note of these.
- 6- In case our Seller or our Authorized Service cannot satisfy your request or complaint please contact the communications means provided within the guide.
- 7-The producer always keeps the right to make any technical changes on the product without prior notice.

Sincerely yours,

Table of Contents

1. Matters Requiring Attention During Shipping, Transportation and Montage
2. Rules for Use, Maintenance and Repair
3. Conditions Outside Warranty Coverage
4. Rules for Electrical Parts Guide

1. Matters Requiring Attention During Shipping, Transportation and Montage

- 1.1. The products must be protected against shocks during transport and storage. During storage and before assembly of the product, provide closed storage areas where the temperature will not drop below 15°C.
- 1.2. The packaged products must be protected against rain, water, humidity, dust and fire which can cause damage to the product and the packaging to cancel.
- 1.3. Do not pile products on top of each other or crush packaging on top of each other. Take precautions against spills and falls.
- 1.4. Wood, metal, mirrors or any of the products should not have puddles of water, if there are any they should be cleaned up immediately. The product should not be exposed to water directly or indirectly.
- 1.5. The products should be transported and placed according to the transportation and protection signs found on the package.
- 1.6. During the forklift carriage of products shipped in crates or cardboard packaging you should make use of pallets.
- 1.7. In order to prevent products from breaking during their storage and protection they should be placed in accordance with the direction indicated on the packaging and placing them on top of one another should be avoided.
- 1.8. Product parts removed from packages opened for the purpose of carrying to floors should be checked and carried in a protected manner.
- 1.9. Do not leave your products for a long time in buildings under construction.
- 1.10. During the delivery of products, external packaging should be checked for damage. If it is damaged, it should be indicated in the delivery note and notified to the relevant point of sale.
- 1.11. While designing the infrastructure prior to the installation, consider the technical specifications of the products and dimensions indicated.
- 1.12. The packaging of the product should be opened by Authorized Service during installation.
- 1.13. The installation should strictly be undertaken by the authorized service.
- 1.14. For the installation of the product, you should use the installation pack supplied with the product or the recommended auxiliary materials. Use our special screws and dowels for brick or concrete walls. Drill hole on the brick or concrete walls in the same diameter as dowel. Pile the plastic dowel in the same level as the wall and screw it by using special screw. For other wall types, installation parts can be supplied from specialized stores.
- 1.15. Materials that expand while freezing such as cement, plaster, etc. should not be used in installation.
- 1.16. The protective film layer on the product should not be removed before transportation, installation and repair procedures are completed.

2. Rules for Use, Maintenance and Repair

- If the construction activities in the bath will continue after installation, do not remove the folio layer on the product and apply full protection to the product.

Possible Problems and Their Solutions

| Problem | Solution |
|--|---|
| <ul style="list-style-type: none"> The surface of the product is dull and/or scratched. | <ul style="list-style-type: none"> If your product is new, the protective film layer on it might not have been removed. If dullness/scratches occur after a certain period of use, you may be using incorrect cleaning materials. |
| <ul style="list-style-type: none"> My product stretches | <ul style="list-style-type: none"> Check if the Wall hangers are installed on the wall or not. The wall hangers must be used in order to preserve the rigidity of the product. |
| <ul style="list-style-type: none"> Water leakage under the product | <ul style="list-style-type: none"> Check the silicone application between the product and the wall Check the isolation. |
| <ul style="list-style-type: none"> The siphon drain of my product clogs frequently, | <ul style="list-style-type: none"> Hair, soap, etc. could clog the siphon in time. Clean the siphon drain with a drain opener from time to time. |

If your problems persist please contact the nearest Authorized Service.

2.1. Cleaning of Wooden Surfaces:

Cleaning cloth: Cotton-based damp cloth

Cleaning agent: Wipe with cotton-based, slightly damp cloth. Do not use any cleaning materials.

Cleaning method: Apply the damp cloth up and down on the surface without exerting too much pressure. Do not rub with exerting pressure. Then, the whole surface should be dried with a dry cloth.

2.2. Cleaning of Acrylic, Steel and Metal-Covered Surfaces;

Cleaning cloth: Cotton-based damp cloth

Cleaning agent: Clean water, soapy water, non-scratching and non-solvent cleaning materials

Cleaning method: Apply the damp cloth up and down on the surface without exerting too much pressure.

Rinsing: Cleaning material on the surface should be removed with damp cloth and the whole surface should be dried with a dry cloth.

2.3. Cleaning of Mirrors and Glass Surfaces;

Cleaning tool: They should be wiped with a damp, soft cloth.

Cleaning agent: Abrasive chemicals and ammonia-based, acidic or alkaline cleaning agents should not be used for cleaning the mirrors. Any cleaning agents should not be directly sprayed on the mirror's surface. Cleaning should not be performed using materials which could scratch the surface such as spatulas, etc. When patterned products are concerned, clean the glasses with a soft cloth and warm water.

Cleaning method: You should not attempt to remove ant strong stains while the glass is dry, the stains should be gently wiped with a cotton cloth dipped in clean hot water and squeezed well. Care should be given so that water does not collect on the lower edge of the mirror.

2.4. Products should not be cleaned with cleaners that are acidic and that contain abrasive dust (bleach, cleaners with ammoniac, hydrochloric acid etc). In case of contact, it should be thoroughly cleaned with water immediately

2.5. Products should be protected against impacts during handling and use.

2.6. The product should be protected against impacts caused by hard and sharp objects.

2.7. No cutting, drilling or painting process should be made on the products. The electrical parts in the product should not be intervened. All procedures related with the products should be performed by Authorized Services.

2.8. It should be checked before and after use whether there is any water leakage caused by the installation or water accumulation on the furniture. If the water accumulation is not eliminated on time, the risk of swelling and inflating may occur. In this case, you should consult the Authorized Service that made the installation.

2.9. The hinges that enable the doors to move are designed only to bear the load of doors. Although they have a certain tolerance, additional loads exerted on the hinges may cause the hinges to lean out and may lead to functional problems.

2.10. During the cleaning of products, silicone material used for water insulation after the installation of the washbasin should be absolutely removed. If the silicone application was performed to impair the visual appearance, then notify the Authorized Service that made the installation to fix it.

2.11. The procedures to be performed with solvent materials such as paint, floor vanish etc may damage the metal enclosure of bathroom furniture. Therefore, the procedures to be made with such materials should be completed prior to the installation of bathroom furniture.

2.12. Do not leave wet laundry, damp cloths and materials used during cleaning (such as bucket, bowl etc.) on the wooden materials.

2.13. Steel surfaces are sensitive to impacts. Small scratches can be covered with steel paste. However, the grinding effect on the area where retouching procedure was applied will fade away.

2.14. Electrolysis coating method was applied on the handles. If cleaned with unsuitable cleaning materials, there is a risk of removal.

2.15. Do not place objects on furniture that have a high temperature degree and that might impair the surface.

2.16. Avoid contact of the product with high degree alcohol, naphtha, thinner, acetone etc.

2.17. Avoid any contact of the product with paint in the rays of the sun and ultraviolet which can yellow them / make lose their color

2.18. Products should not be used in the spaces that have insufficient ventilation and high moisture ratio (basement floor etc)

2.19. If the bathroom furniture will be installed next to the tub and shower tray, then shower enclosure should be fitted in between.

2.20. Ensure sufficient ventilation and drying after taking a bath or shower in bathroom. If the walls remain wet for long periods of

time, fungus, mould stains or material damages may occur.

2.21. Against the risk of swelling, inflating, staining or corrosion, any of wood, metal, mirror and other parts of the products should not be exposed to water directly or indirectly, in case of this, the product should be wiped and cleaned immediately.

2.22. Keep lighted cigarettes away from the product.

3. Conditions Outside Warranty Coverage

Shipping Storage

3.1. Deformations to the product surface during the shipping and transportation carried out after the products are delivered or any breakages which may occur as the result of impacts,

3.2. Deformations and breakages on the surfaces of products which remain at the construction site for a long time without protection,

3.3. Damage to the product as the result of effects of the water and/or humidity in the environment during the storage and use of the products,

3.4. Products damaged by each other due to stacking on top of each other during storage, shall be treated out of scope of the warranty.

Installation

3.5. Failures which occur as the result of incorrect installation, maintenance, repairs and disassembly performed by unauthorized persons,

3.6. Defects caused by the failure to install or use the product in compliance with the technical catalogue, Installation or User's Guide

3.7. Factors which impact the installation of the product, resulting from hot-cold water, waste water outlet installements, or the wall or floor not being level,

3.8. Failure to use the auxiliary materials accompanying the product, or recommended auxiliary materials in installation

3.9. Defects that are visible in the delivery/assembly despite the written confirmation and for which the orderer does not reserve the rights arising from this document.

3.10. Surface deformations and failures occurring due to small particles in the plumbing (stone, sand, gravel, etc.) and encrustation,

3.11. Failures where cutting and drilling procedures not made by Authorized Service

Use, Cleaning and Maintenance

3.12. Deformations and failures on the surface, electronic parts due to practices other than the use functions specified in the User Guide

3.13. Deformations and dullness occurring on the surface of products wiped with cleaning substances containing acid and cleaning substances containing abrasive powders,

3.14. Deformations and dullness occurring on the surface of products wiped with rough cleaning substances (wire sponge, hardened sponge, etc.),

3.15. Pattern degradation due to the patterned glasses of the cabins being cleaned by a cleaning agent other than water.

3.16. Deformations that welding electrode sparks, flammable substances during alterations made in the bathroom spaces and cigarettes may cause on the product surface,

3.17. Failures occurring due to use of parts other than original spare parts,

3.18. Defects caused by lighting materials (Rays of the Sun, LED, fluorescent, spot etc.) shall be treated out of scope of the warranty.

3.19. Damages in electronics due to voltage change,

3.20. Damages that may occur due to insufficient ventilation of the environment and leaving the product damp and wet.

3.21. Failures to declare the approved document or invoice showing that the product is within the warranty period,

3.22. Damages and failures that may occur as a result of using the product in a manner that does not comply with "Considerations During Installation" as described in the Article 1 and "Rules for Use, Maintenance and Repair" in the Article 2.

3.23. Disassembling and disposal of disassembled products, excluding warranty internal failures, are the responsibility of our customers.

3.24. The disassembled products should be evaluated within the framework of the EXCAVATION SOIL, CONSTRUCTION AND WASTES CONTROL REGULATION, and the district municipality should be contacted for disposal.

4. Rules for Electrical Parts Guide

The assembling and disassembling of electronic components must be executed by a qualified and authorised electrician.

The connector that we provide for electrical connection is suitable for general-purpose connection types. Electrical connection applications may differ in your region or residential area. Connectors suitable for the network to which the product will be connected must be supplied.

Protect your product with a fuse.

The products with electrical components contain "a light source of energy efficiency class G" to Regulation (EU) No 2019/2015.

Removal and Disposal



Recycling or disposing of electrical appliances appropriately. Never dispose of electronic equipment with household waste. Observe the regulations applicable in your area.



Risk of electric shock! Touching live parts can cause serious injury or even death. Removal and repairs should only be carried out by a qualified electrician.

Removing an appliance:

1. Switch off the power supply and ensure it cannot be switched on again.
2. Disconnect the cables junctions.
3. Loosen and remove the electrical components.
4. Dispose of electrical materials, glass and furniture parts separately according to the regulations applicable in your area.

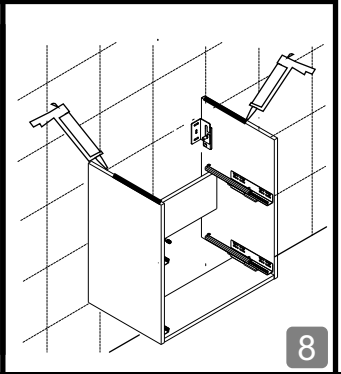
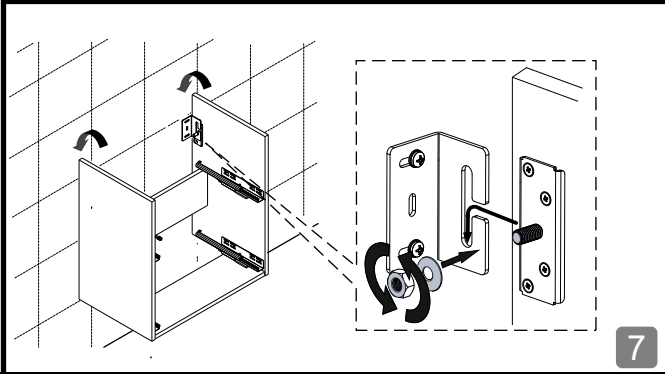
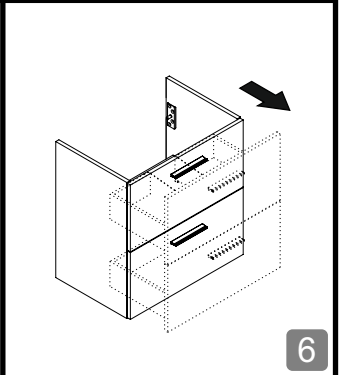
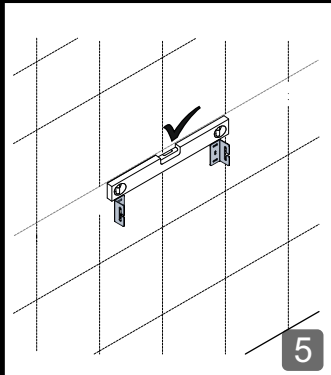
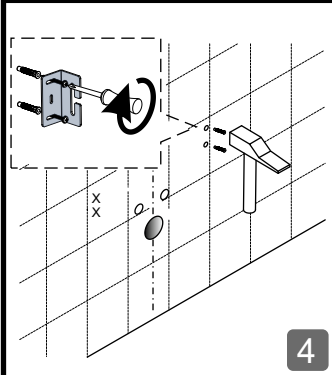
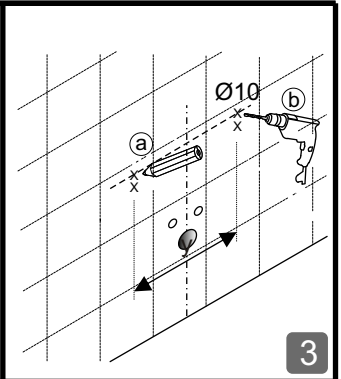
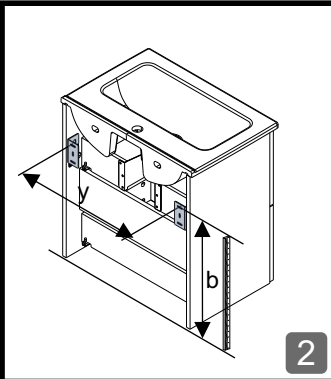
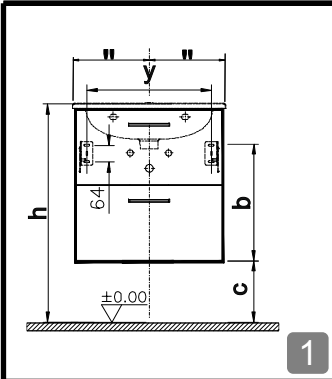
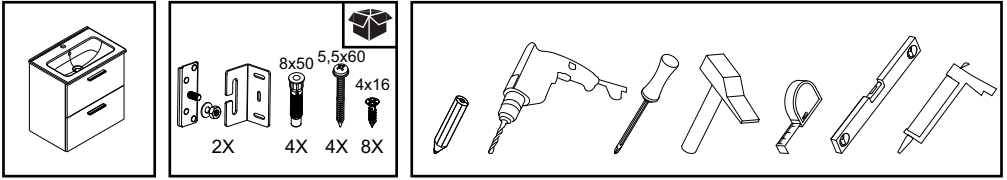

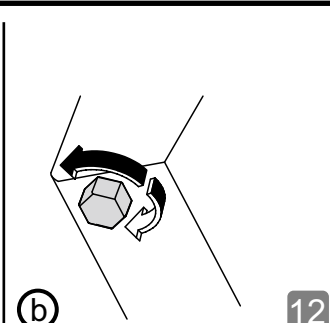
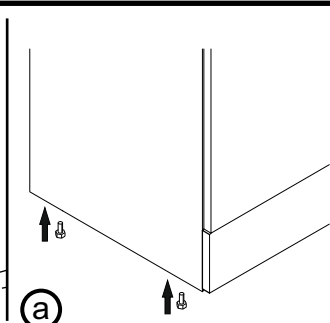
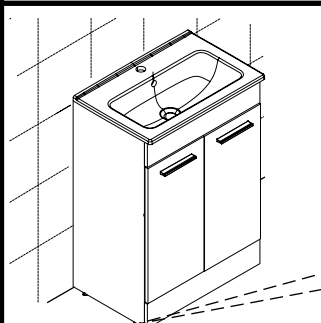
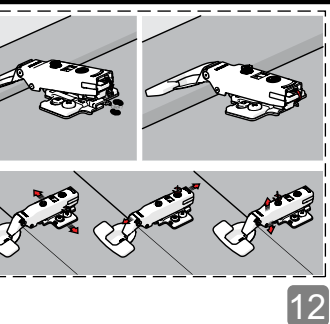
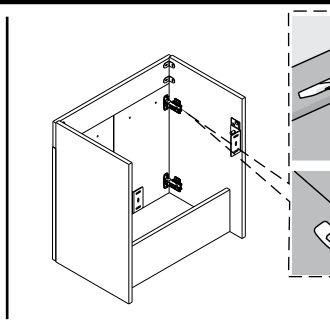
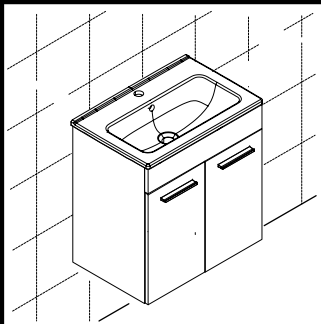
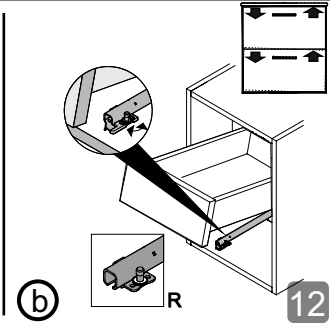
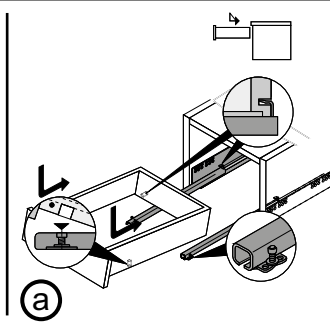
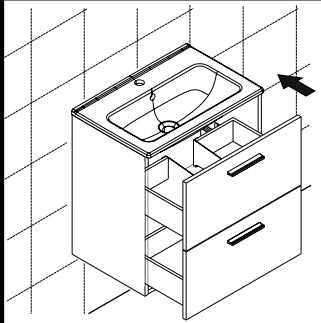
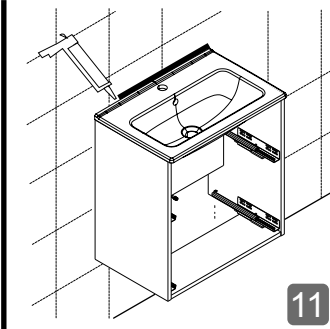
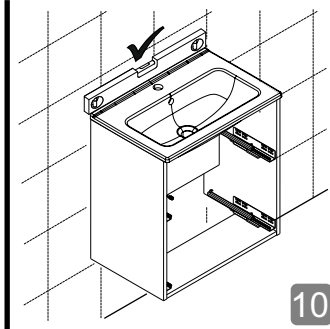
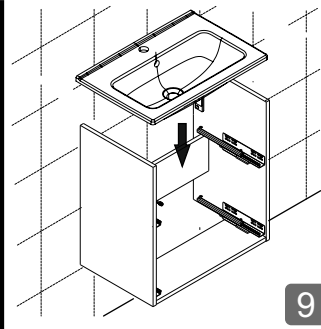

Montaj Kılavuzu • Installation • Montage

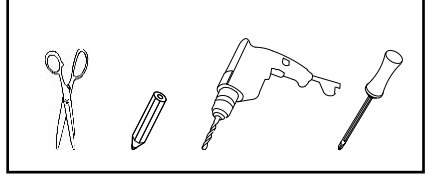
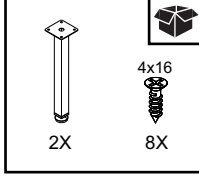
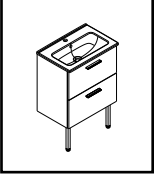

Ayak montaj adımları, ayaklı satın alınan ürün için geçerlidir.
Installation of the legs is for the purchased product with legs.
Montage des pieds est pour le produit acheté avec pieds.

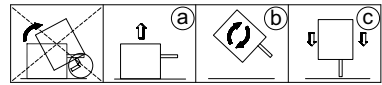
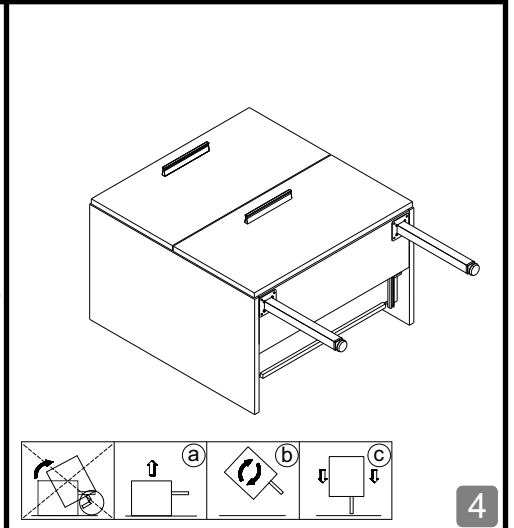
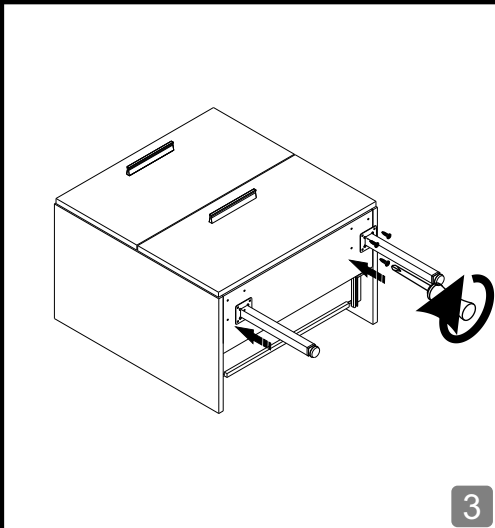
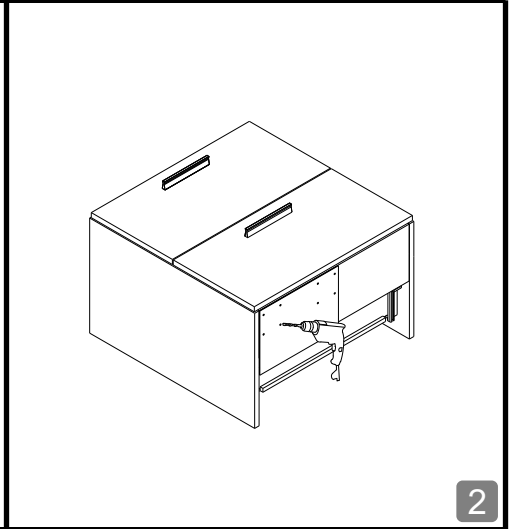
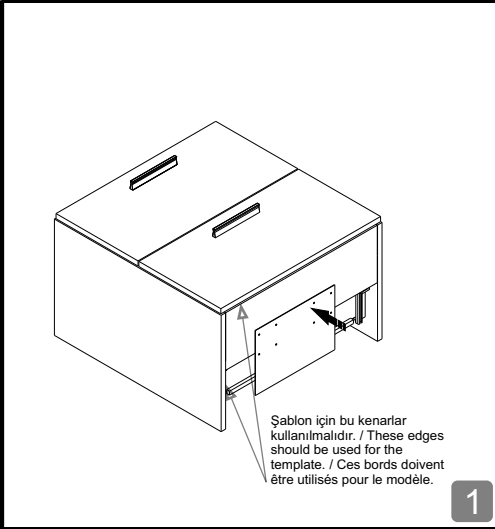

Ayak Montaj Şablonu
Template of The Legs Installation
Modèle d'Installation des Pieds
Vorlage für die Installation von The Legs

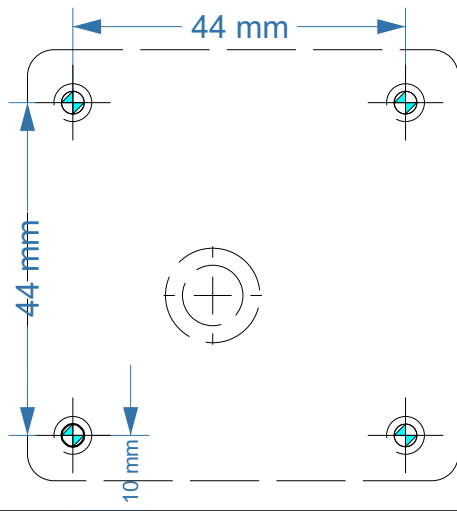

SOL / LEFT / GAUCHE

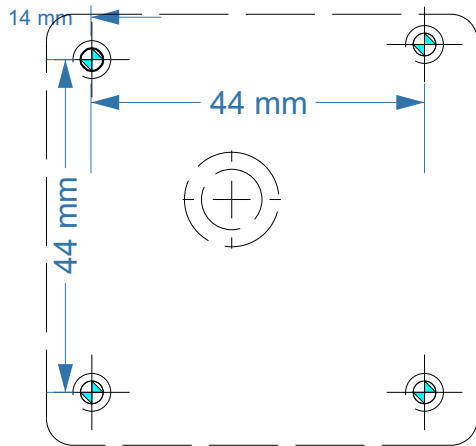

SAG / RIGHT / DROIT



Buradan Kesiniz / Cut Here / Couper Ici

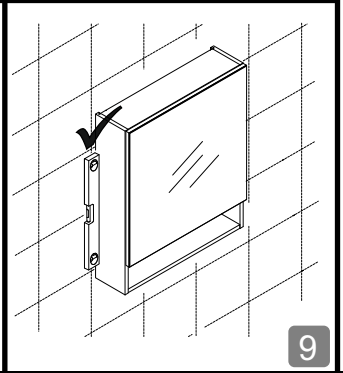
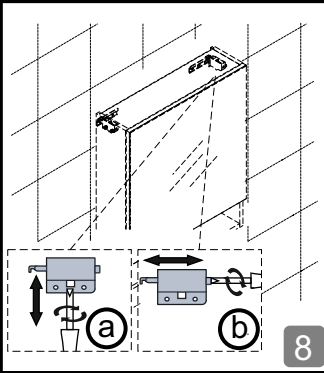
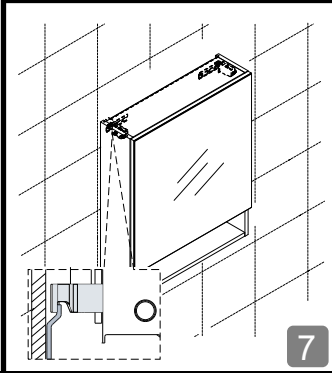
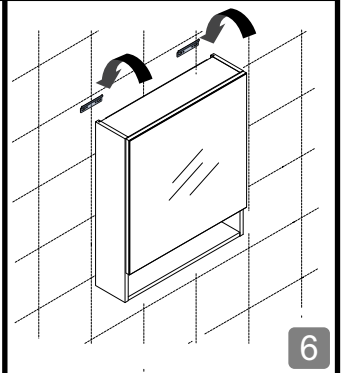
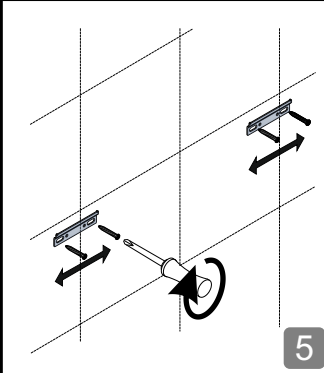
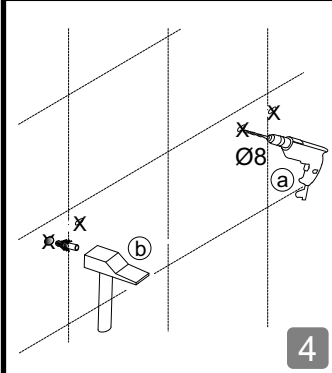
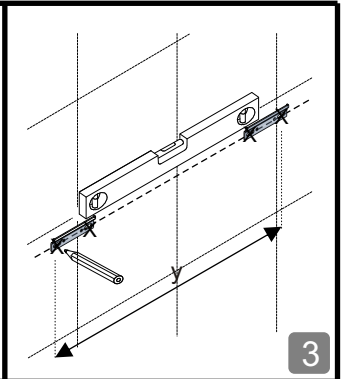
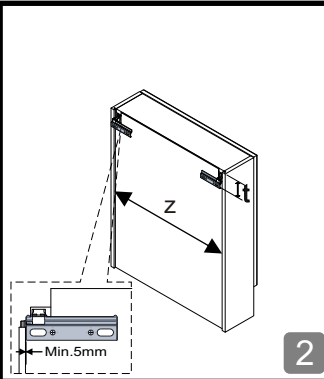
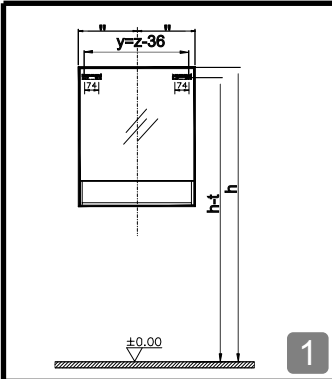
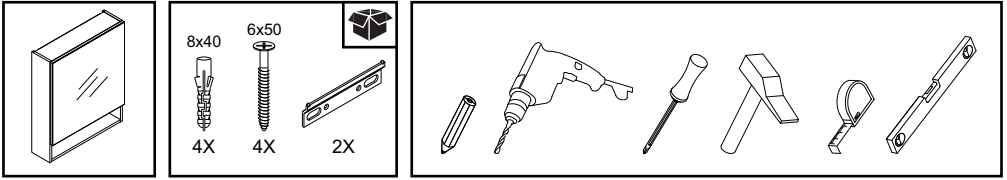

Montaj Kılavuzu • Installation • Montage

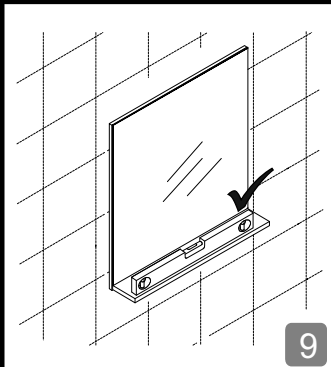
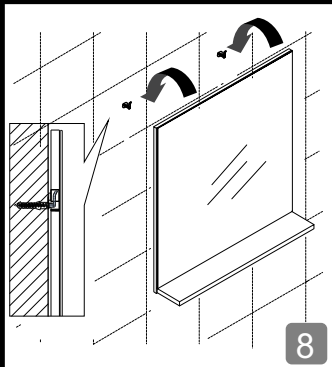
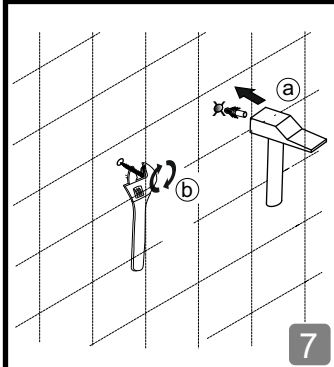
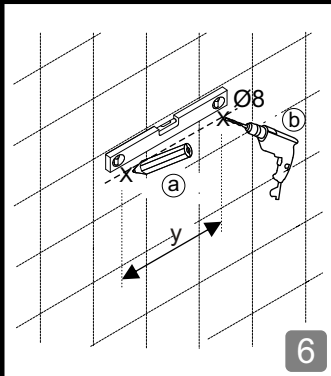
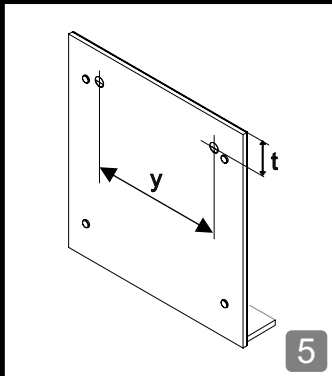
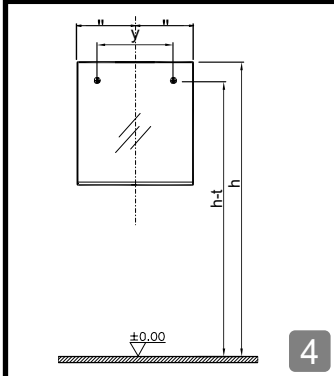
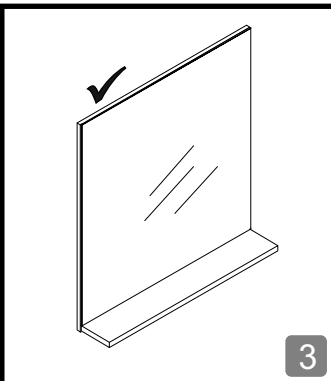
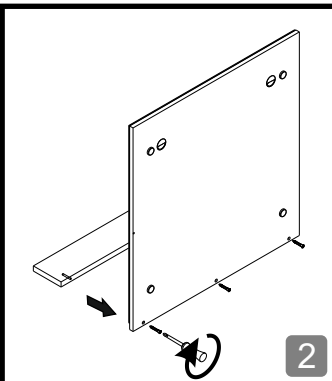
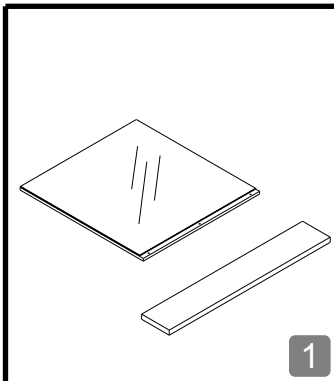
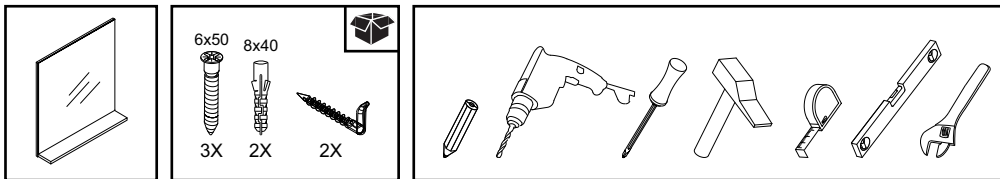

Montaj Kılavuzu • Installation • Montage

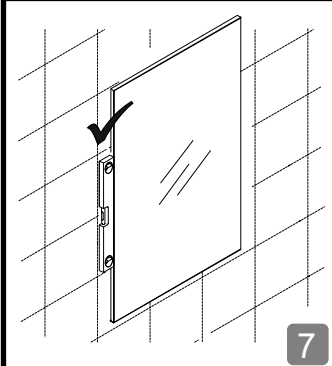
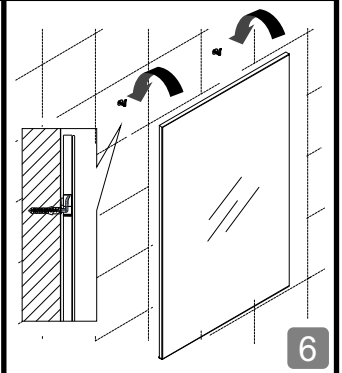
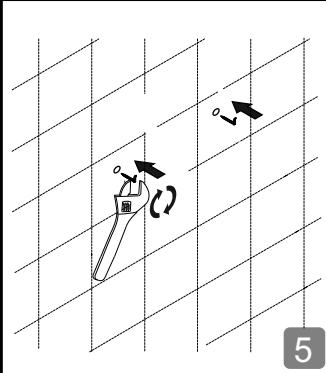
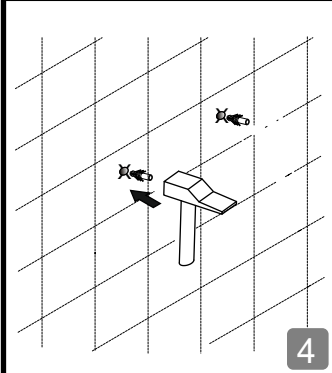
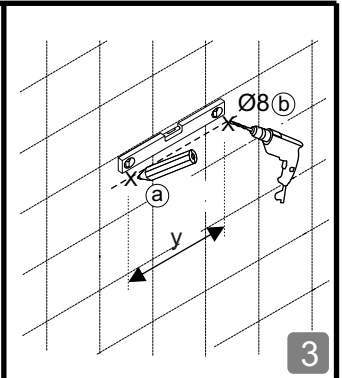
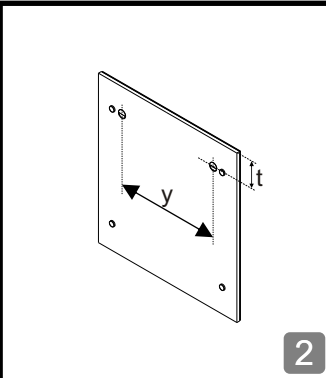
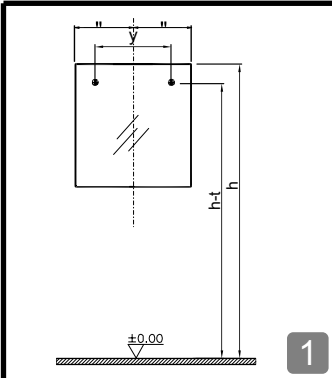
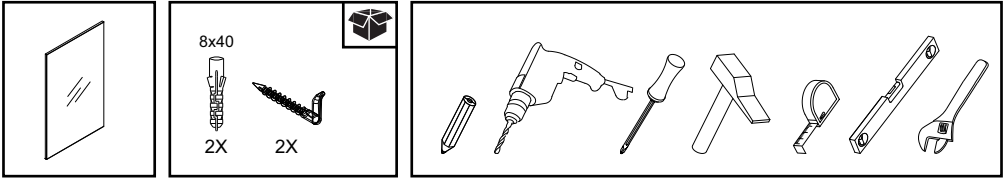

Montaj Kılavuzu • Installation • Montage

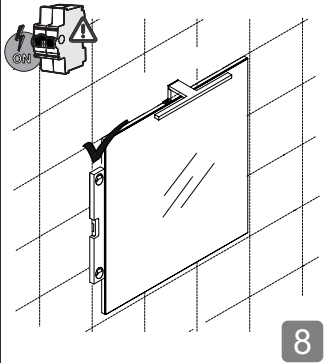
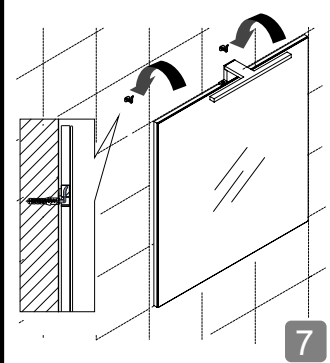
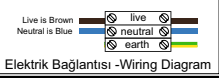
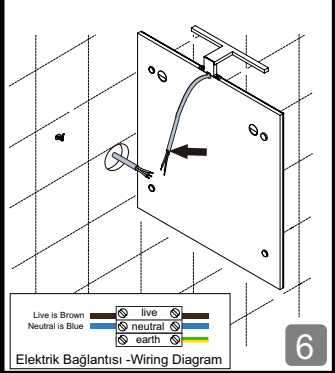
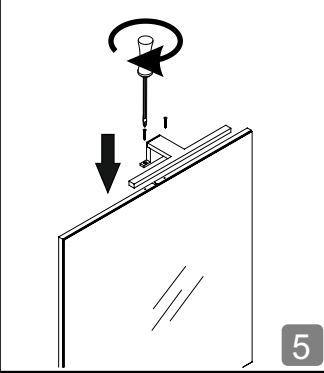
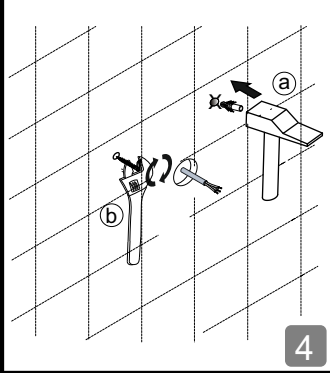
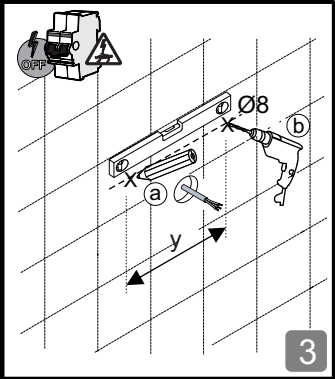
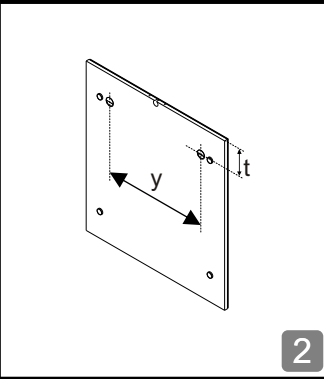
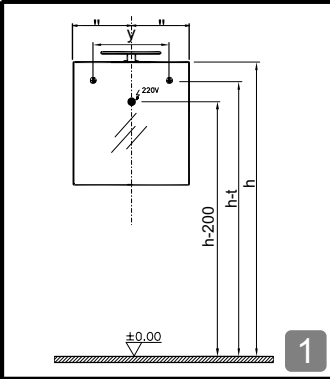
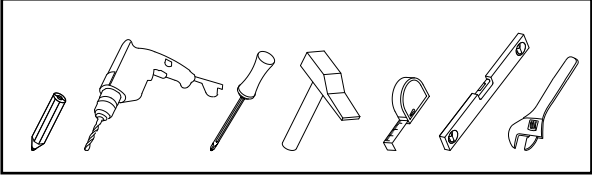
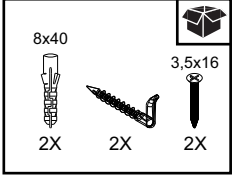
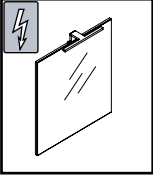

Söküm Kılavuzu . Disassembly . Demontage . Démontage

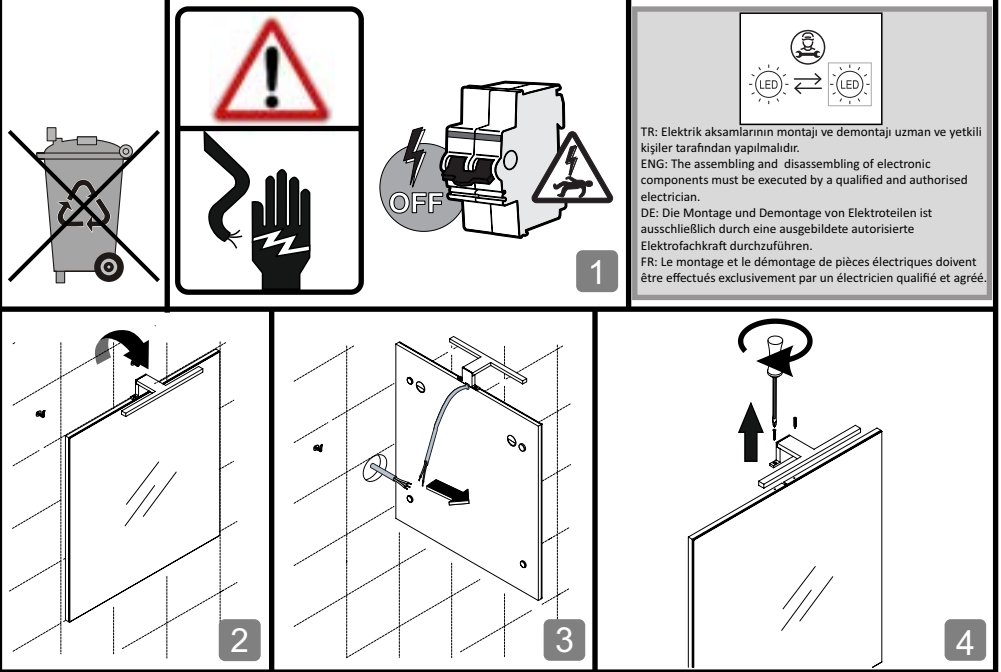

Bu ürün, 2019/2015 Sayılı (AB) Yönetmeliğine göre "G enerji verimliliği sınıfına sahip bir ışık kaynağı" içerir.
This product contains "a light source of energy efficiency class G" to Regulation (EU) No 2019/2015.
Dieses Produkt enthält "ein Leuchtmittel der Energieeffizienzklasse G" gemäß Verordnung (EU) Nr. 2019/2015
Ce produit contient "une source lumineuse de classe d'efficacité énergétique G" conformément au règlement (UE) n° 2019/2015

Montaj Kılavuzu • Installation • Montage

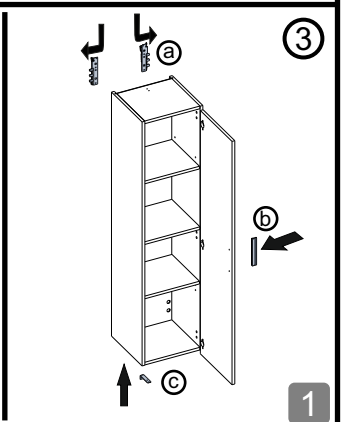
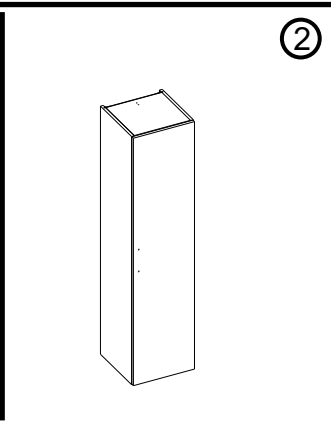
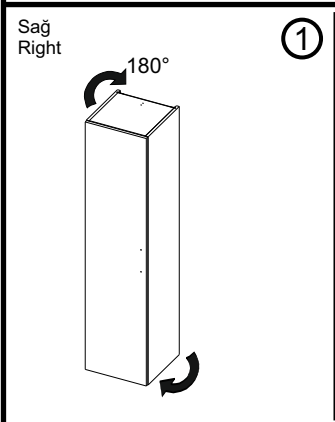
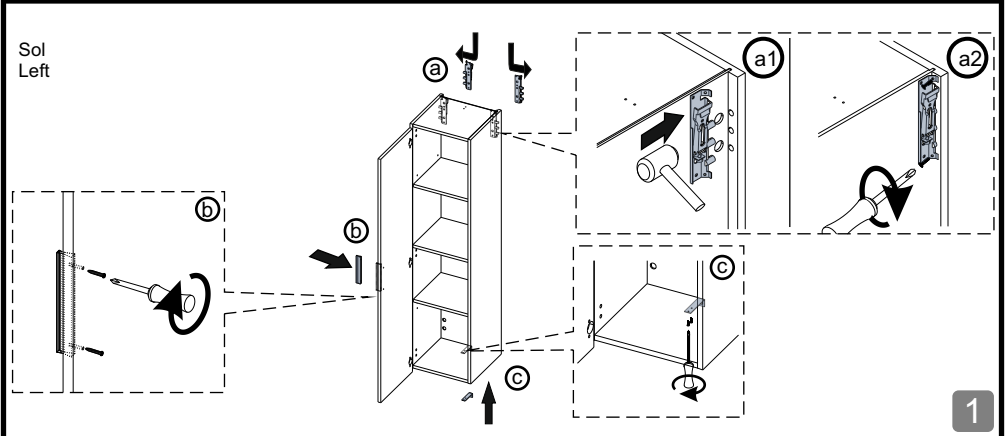
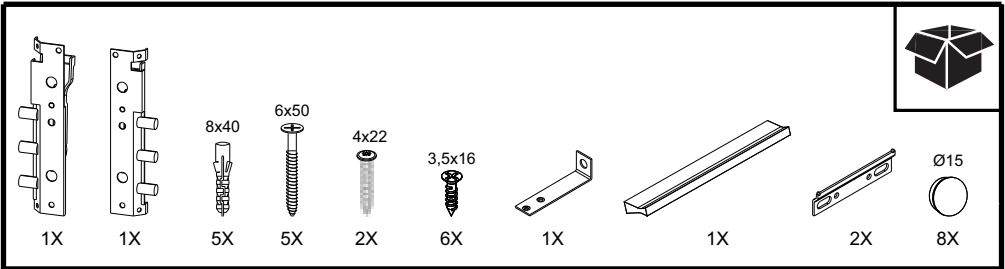
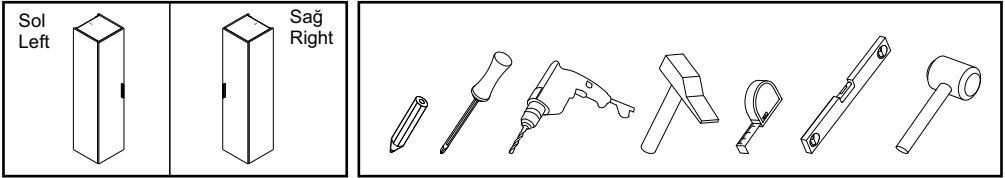

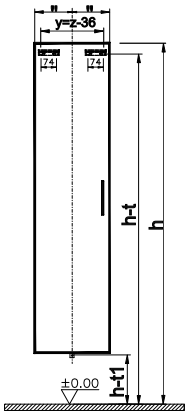

2

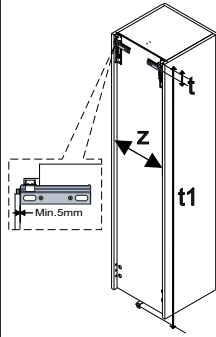

3

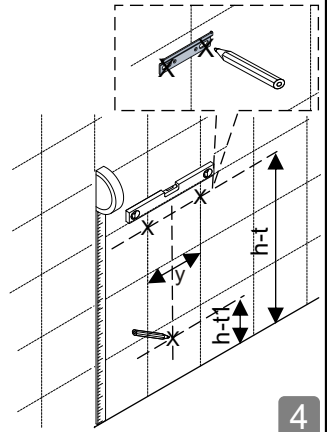

4

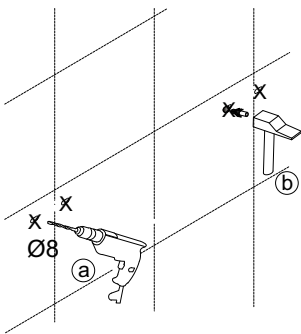

5

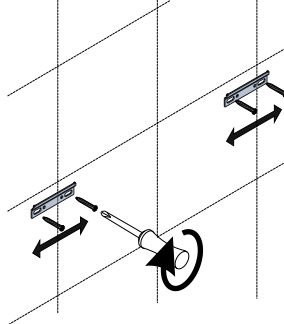

6

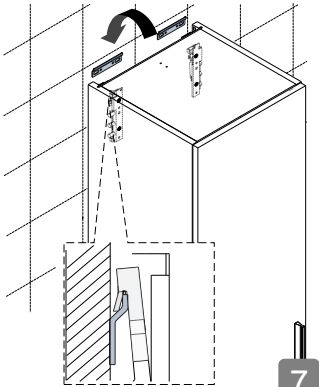

7

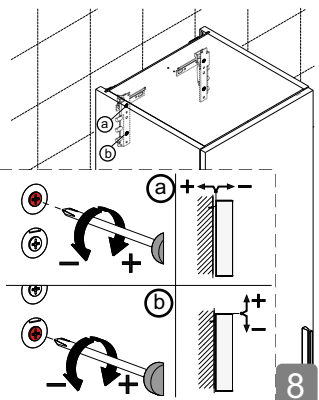

8

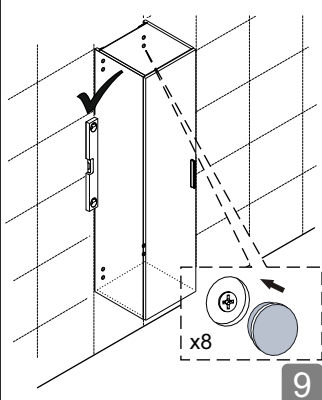

9

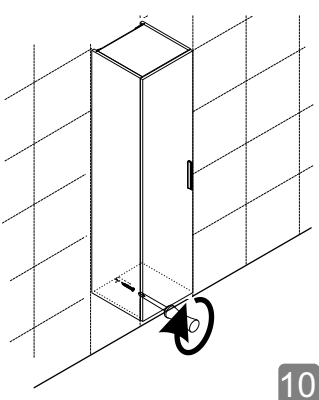

10