

**Series 2, Fully-integrated
dishwasher, 45 cm
SPV2HKX42G**



**Connected dishwasher with noise
reduction at any time via the Home
Connect App.**

- **ExtraDry:** extra drying option for difficult-to-dry loads.
- **Height Adjustable Top Basket:** offers extra space, especially for tall dishes.
- **InfoLight:** a red light on the floor indicates whether the dishwasher is switched on or off.
- **Silence on demand:** up to 30 min noise reduction at any time via the Home Connect App.
- **Home Connect:** home appliances with smart connectivity for an easier everyday life.

Technical Data

Energy Efficiency Class: E
 Energy Consumption for 100 cycles Eco Programme: 76 kWh
 Maximum number of place settings: 10
 The water consumption of the eco programme in liters per cycle: 8.9 l
 Programme duration: 3:40 h
 Airborne acoustical noise emissions :46 dB(A) re 1 pW
 Airborne acoustical noise emission class:C
 Built-in / Free-standing: Built-in
 Height of removable worktop: 0 mm
 Dimensions of the product (HxWxD):815 x 448 x 550 mm
 Min. required niche size for installation (HxWxD):815-875 x 450 x 550 mm
 Depth with open door 90 degree: 1150 mm
 Adjustable feet: Yes - all from front
 Maximum adjustability feet: 60 mm
 Adjustable plinth: Both horizontal and vertical
 Net weight:27.1 kg
 Gross weight: 28.9 kg
 Connection rating: 2400 W
 Fuse protection:10 A
 Voltage: 220-240 V
 Frequency: 50; 60 Hz
 Length electrical supply cord: 175.0 cm
 Plug type: GB plug
 Length inlet hose: 165 cm
 Length outlet hose: 205 cm
 EAN code:4242005467310
 Installation typology: Integrated

Optional accessories

SGZ0BI02	decorative strips stainless steel 81,5cm
SGZ1010	inlet and outlet hose extention
SMZ5000	Dishwashing aid set
SMZ5002	Silver polishing cassette
SMZ5003	Retractable hinge f. high corpus dimens.
SMZ5300	GlassSecure Tray



Series 2, Fully-integrated dishwasher, 45 cm SPV2HKX42G

Connected dishwasher with noise reduction at any time via the Home Connect App.

- Dimensions (HxWxD): 81.5 x 44.8 x 55cm

¹ Scale of Energy Efficiency Classes from A to G

² Energy consumption in kWh per 100 cycles (in programme Eco 50 °C)

³ Water consumption in litres per cycle (in programme Eco 50 °C)

⁴ Duration of programme Eco 50 °C

Performance

- Energy Efficiency Class¹: E
- Energy² / Water³: 76 kWh / 8.9 litres
- Capacity: 10 place settings
- Programme duration⁴: 3:40 (h:min)
- Noise level: 46 dB(A) re 1 pW

Programmes / functions

- Noise Efficiency Class: C
- 5 programmes: Eco 50 °C, Auto 45-65 °C, Intensive 70 °C, Express 65°, Favourite
- Default favourite programme: Pre-Rinse
- 3 special options: Remote Start, Extra Dry, SpoD VarioSpeedPlus
- Add-On functions via Home Connect app: Hygiene+, Silence on Demand
- Machine Care Programme

Flexible design elements

- Vario baskets
- Height adjustable top basket when empty
- Low friction wheels on bottom basket
- Rack Stopper to prevent derailing of bottom basket
- 2 foldable plate racks in bottom basket
- Knife rack in top basket
- Variable cutlery basket in bottom basket
- Upper rack cup shelf

Innovations and technology

- Home Connect ready on WLAN
- Heat exchanger - Hygienic and efficient drying
- DosageAssist detergent dispenser
- EcoSilence BLDC drive
- Automatic detergent detection
- AquaSensor III
- AquaMix - Glass protection system

Design features

- Push button top edge controls
- InfoLight (Red) - Light projection on the floor
- DuoPower spray arm in upper basket
- Time delay (3, 6 or 9 hours)
- Acoustic end of cycle indicator
- Self-cleaning filter system with 3 piece corrugated filter
- steam protection plate
- AquaStop: Bosch's warranty in case of water damage - for the lifetime of the appliance. Please find warranty terms under <https://www.bosch-home.co.uk/customer-service/care-protection-and-parts/additional-warranties>
- Stainless steel interior

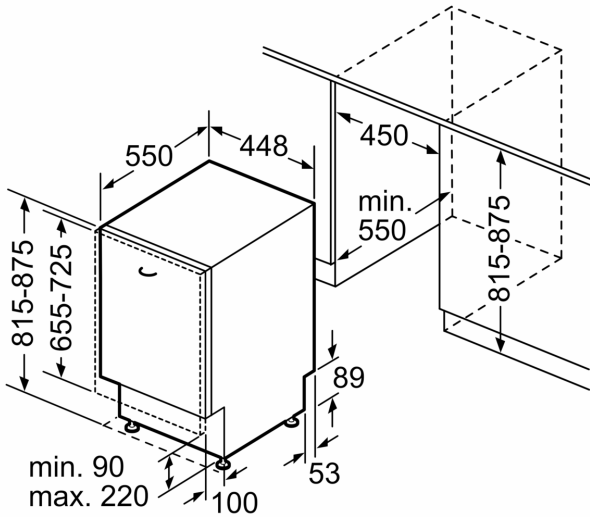

**Series 2, Fully-integrated
dishwasher, 45 cm
SPV2HKX42G**



measurements in mm

measurements in mm



 socket
 values with extension kit