

# Instaflow

Stored Water Heater 1.5kW - 5L, 2kW - 10L, 2kW - 15L

## Product Codes

Stored Water Heater - 1.5kW - 5L	SPINSF500S
Stored Water Heater - 2kW - 10L	SPINSF100S
Stored Water Heater - 2kW - 15L	SPINSF150S

## Installation

- Wall hung – brackets supplied
- Dielectric connectors
- Pressure relief device

## End User

- Stored hot water heater fed by cold mains water supply
  - Available as 5l, 10l or 15l capacity
- Everything supplied for ease of installation (additional accessories available if required)
- Under-sink installation with top connectors
- Quick heat up times and variable temperature settings (with a maximum temperature of 75°C)
- Corrosion resistant, enamel coated heater tank with magnesium anode protection
- 2 year parts and labour guarantee (UK only)
- Efficient B energy rating



# Instaflow

Stored Water Heater 1.5kW - 5L, 2kW - 10L, 2kW - 15L

## Water Heater

Capacity	5L, 10L, 15L
Power ratings	1.5kW (230V) - 5L 2.0kW (230V) - 10L & 15L
Energy Rating	B
Installation	Wall hung - brackets supplied Dielectric Connectors Pressure Relief Device
Electrical Connection	10A Plug Socket
Temperature Control	Thermostatic
Max Temperature	75°C
Min Pressure	0.5bar
Max Pressure	6 bar
Water Connection	1/2" BSP

### 5 Litre

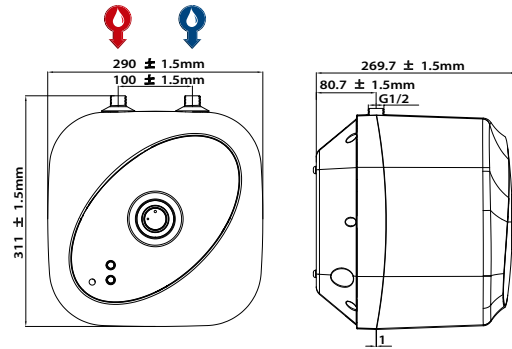

### 10 Litre

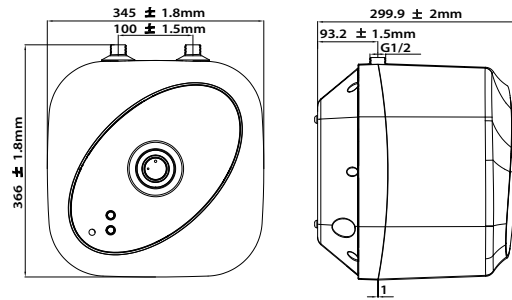

### 15 Litre

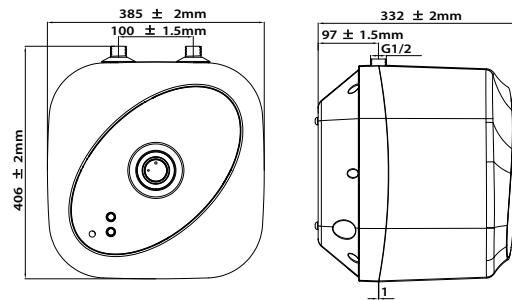

## Accessories

Instaflow Kit A - 2L Expansion Vessel & Non-Return Valve	SPINSFEXV2
Instaflow Kit B - 3.5bar Pressure reducing Valve	SPINSFPRV3
Instaflow Kit C - Discharge Tundish	SPINSFDT

## IMPORTANT MAINTENANCE NOTICE

Replacing specified Triton accessories for this Stored Water Heater unit will aid optimum performance and keep the unit within the allocated guarantee period



2L Expansion Vessel & Non-Return Valve  
SPINSFEXV2



3.5bar Pressure reducing Valve  
SPINSFPRV3



Discharge Tundish  
SPINSFDT

Contact our specification team

Call: 02476 324 776 | Email: [specification@tritonshowers.co.uk](mailto:specification@tritonshowers.co.uk) | Web: [www.tritonshowers.co.uk/specifiers](http://www.tritonshowers.co.uk/specifiers)