

# How to plan & build a timber deck

A timber deck can be built on level or sloping ground and on one or more levels to create an attractive, solid base for garden dining and relaxation – **and you can add a pergola and deck rails or deck panels to complete the picture.**

## Kit

### Tool List

- > Handsaw
- > Circular saw or jigsaw
- > Drill and drill bits
- > Cordless drill/driver
- > Tape measure
- > String line
- > Spirit level
- > Hammer

- > Wood chisels
- > Spade
- > Screwdrivers
- > Plumb line
- > Clamps

### Safety Equipment

- > Dust mask
- > RCD adaptor
- > Goggles
- > Gloves

As you would if working with any timber product, wear gloves to avoid splinters, and goggles when using circular saws, drills or sanders. Avoid breathing in dust when cutting wood by wearing a nose and mouth mask.

Always use an RCD device when employing any power tools outside.



# 1

## Buying the right decking components

To help you get everything you need a project shopping list is on the back page of this leaflet, you'll find advice on calculating material quantities throughout, too.

Buy the timber components about a week before you build the deck to give it a chance to adjust to the temperature outside. Store it close to where it will be used, stacked on level ground on timber bearers, and cover to keep dry.

### Plan the deck

The key to a successful deck is in the planning. First decide on the location: do you want a sunny or shaded location and is privacy a requirement? How big does the deck need to be? Do you want to add interest to the deck with pergola components or combine decking components with paving? Is the site level or will part of the deck have to be supported on timbers set into concrete (see page 5 for instructions). See **Fig. 1** (see page 2) to get an idea of just some of the components we sell – and how they can be used together.

### Work out the deck's proportions

It is essential to plan your deck to scale on paper. Be as accurate as possible with measurements and bear in mind that it is the deck boarding that basically governs the size of the deck. Designing a deck carefully will limit cutting, and board or bearer wastage. For any deck, you will

need to work on the board widths at 140mm plus 5mm gaps in between. The table below will help you calculate your deck's proportions:

- 10 boards and 9 gaps** = 1445mm deck width
- 12 boards and 11 gaps** = 1735mm deck width
- 14 boards and 13 gaps** = 2025mm deck width
- 16 boards and 15 gaps** = 2315mm deck width\*
- 18 boards and 17 gaps** = 2605mm deck width
- 20 boards and 19 gaps** = 2895mm deck width

*\*This is the key deck square, which has been sized to allow the other modules to interlink, creating numerous deck designs.*

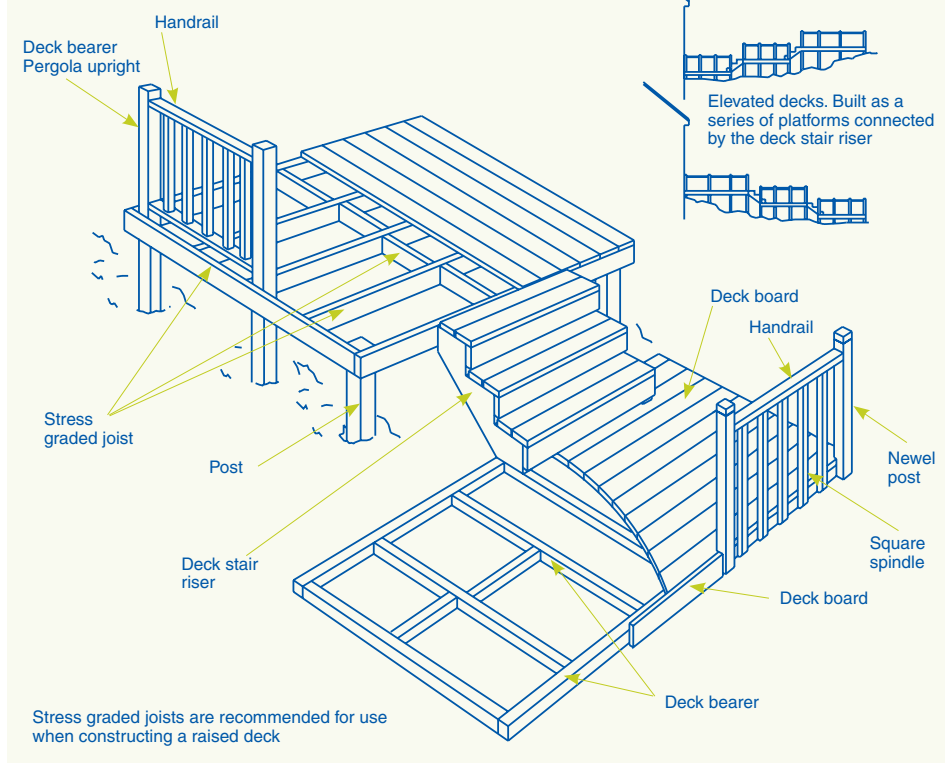
### Skill level required

Basic carpentry skills are enough for building a basic deck; raised decks need careful planning and more experience.

## Planning pitfalls

- > Decks built in permanent shade can be affected by damp and algae growth, so be prepared to clean and treat these once a year to preserve the timber. Avoid very wet areas completely.
- > Very large decks and raised decks may require planning permission, so check with the local council before you start work.
- > Raised decks should not be built with the deck level more than 600mm above ground level without specialist advice.
- > When installing posts or levelling the ground, take special care not to damage underground cabling, pipes or drainage, and do not permanently obstruct manhole covers or other services.

**Fig. 1** Timber decking component parts



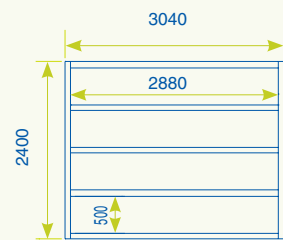
# 2

## Build a basic deck frame

Construct the simple, rectangular deck frame shown in **Fig. 2**

Our basic deck support bearer layout in **Fig. 2** has an overall size of 3040 x 2400mm. The width of this basic deck is based on the use of 21 uncut 2.4m long and 140mm wide deck boards with 20 gaps of 5mm between them (the calculation is:  $(21 \times 140\text{mm} = 2940\text{mm}) + (20 \times 5\text{mm} = 100\text{mm}) = 3040\text{mm}$  total width). The base is designed to provide a complete perimeter with intermediate bearers at no more than 500mm spacings. The bearers are cut to length to suit the dimensions.

**Fig. 2** Basic deck support bearer layout



### Prepare the ground

Ensuring the ground is level and dry will help prolong the deck's life.

**1. Measure out the deck** Following your plan drawing, measure and mark out the deck area, using pegs and a string line. If you are constructing a deck on level ground, further marking out should not be needed, as the bearers can be laid out in the positions where they will be used.

**2. Level the ground** If the ground is slightly uneven, level it off, working in a 1:80 fall for drainage, and make sure that it is firm. If laying the deck over lawn or weeds, remove them, and cover the ground with Wickes Landscaping Fabric to prevent future growth under the deck.

**3. Add pea shingle** If the ground is soggy or likely to become so in wet periods, spread pea shingle over the landscape fabric to a depth of about 25mm. Your bearer frame will bed down on to the shingle and will, to a large extent, be kept off almost permanently wet ground

### Trade Tip

Plan the deck so that it slopes very slightly (a 1:80 fall is sufficient), and use fluted deck boards that run in the direction of the slope; this will aid rainwater run-off, meaning the deck is less slippery and less prone to algae build-up

### Construct a basic deck bearer frame

The basic deck support bearer layout will change with the varying deck board patterns – see **Fig. 3** (see page 3).

#### 1. Lay out the outer deck frame

Mark, cut and lay out the outer frame first using 80 x 80mm bearers. Ensure the frame rests flat and is totally supported. If you find hollows under the frame or areas where it is held off the ground, adjust the ground level to prevent the deck being springy. As you work, treat every cut end with Wickes Decking Preserver.

**2. Fix the deck frame** Clamp then join the frame at each corner using two 150mm (6") timber drive screws. As you proceed, use a spirit level to make sure the frame remains flat. Its corners should be square, too, and you can check this by measuring the frame's diagonals; they should be equal.

**3. Fit intermediate bearers** Now mark, cut and fit the intermediate bearers, remembering the maximum 500mm spacing limit, and checking they are flat with a spirit level. If longer bearers are needed, these can be clamped then joined together by screwing together off cuts with 150mm (6") timber drive screws.

### Trade Tip

When fixing your deckboard to the frame, use decking screws as they can easily be removed without damaging the wood. Clamping timbers together before screwing stops them moving out of alignment during the fixing operation. Don't just use preserver on cut ends – use it in drill holes to help prolong the deck's life, too.

# 3

## Fixing deck boards to the frame

With the basic deck support bearer frame complete, you can begin to lay deck boards.

The different deck board layouts shown in **Fig. 3** from chevron to diagonal, are created using 140mm wide boards and 80 x 80mm bearers. Plan your layout before assembling your bearers, as the pattern will affect the spacing and number of bearers. For example, double bearers will be needed for some chevron styles see **Fig. 4**.

### 1. Check the deck board layout

Loose-lay boards initially to determine what the gaps will actually need to be – the variations in timber mean you should not stick rigidly to fixing the first board, measuring or using a 5mm spacer, then fixing the next board and so on.

**2. Secure the deck boards** Once you are happy with the layout and spacing of the deck boards, fit and secure them to the bearers with 65mm (no.8 x 2½") decking screws, using two screws per board to each and every bearer to avoid cupping.

### Trade Tip

Gaps between decking boards should be at least 5mm to allow for expansion and for rainwater to drain through freely – cut a piece of timber to 5mm and use between boards for a consistent gap (Wickes flooring spacers do the same job).

### Trade Tip

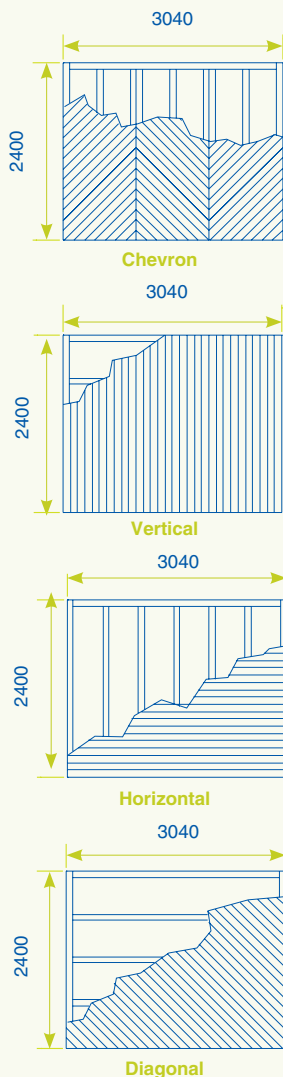
If you are joining two cut deck boards together in a long run, screw them down at an angle 10mm from the end of each board to securely fix them to the joist beneath.

Locate the screws about 15mm in from the edge of each board and in a hollow, see **Fig. 5** over-sized and trimmed later, see **Fig. 6**.

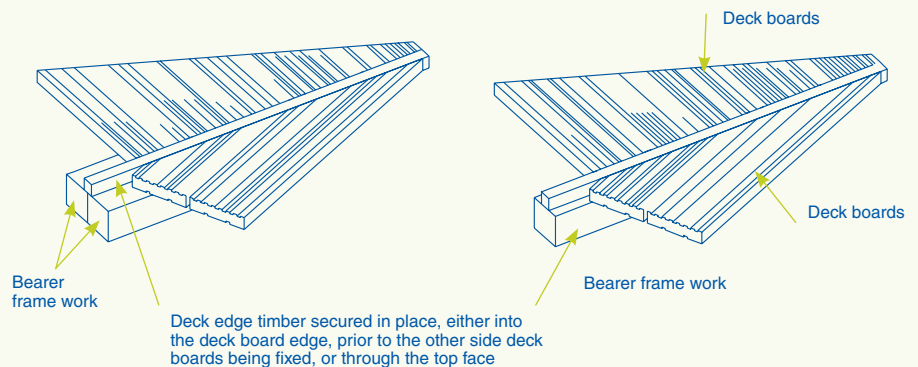
**3. Cut curved edges** If you want to create a curved edge, bear in mind that the unsupported decking cannot be more than 150mm away from a bearer. Mark out curves using a string line in an arc or with a piece of timber fixed to create an arc see **Fig. 7**.

**4. Edge the deck** Add deck boards around the edges to frame the deck and finish it neatly see **Fig. 8** (see page 4).

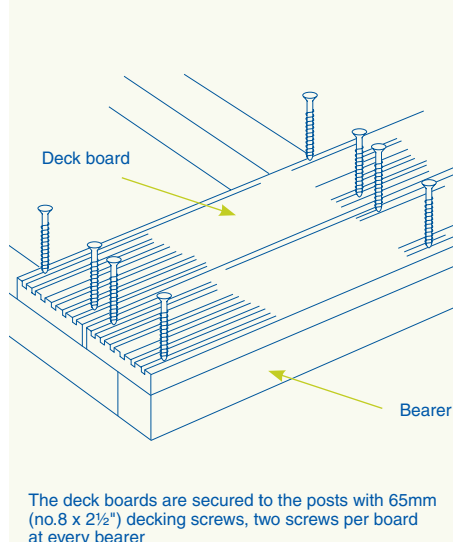
**Fig. 3** Basic deck board layout



**Fig. 4** Bearers for chevron deck board layout

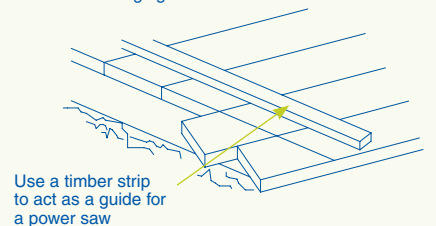


**Fig. 5** Securing deck boards to bearers

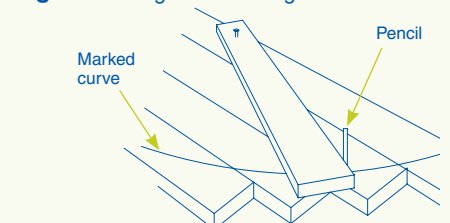


**Fig. 6** Trimming deck boards to size

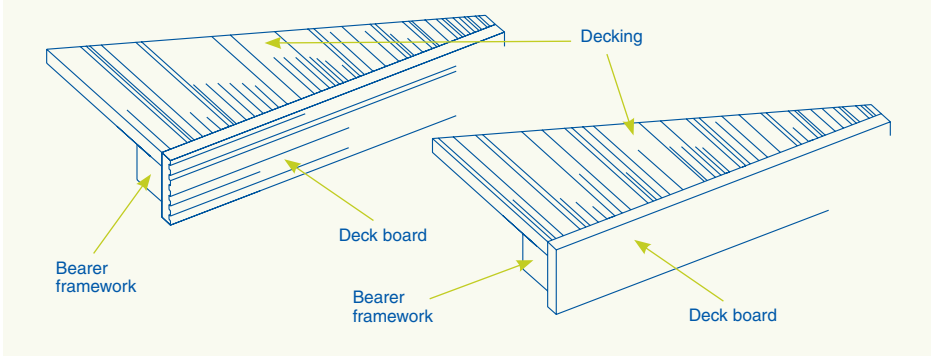
Mark the timber using a timber board or stringline from a central point and use a jigsaw to carefully cut the overhanging deckboards



**Fig. 7** Creating a curved edge for a deck



**Fig. 8** Edging the deck with deck boards



# 4

## Creating shaped decks with modules

Looking to create a more intricate deck shape? You can build it simply by using our clever module system

### Create simple bearer layout modules

It's likely that your deck will be more than the basic rectangle shown on page 2, so we've created a range of five simple deck bearer layout modules for you to replicate (labelled A to E in **Fig. 9**). They include a large and smaller square, a large and smaller triangle, and a narrow rectangle.

Each layout module's construction is simple to follow, and is built with 80 x 80mm bearers. All measurements shown are in mm. Each one has a materials shopping list next to it (see **Fig. 9**).

If your planned deck will be of a different size to ours, you can still use these modules to draw out your own design and calculate your own material requirements.

### Combine the bearer modules to create shapes

Each of our five modules can be used in combination with the others to create a whole variety of deck designs and sizes, plus deck board arrangements see **Fig. 10** (see page 5). The range of possibilities is endless – and don't forget that these modules can be used at different levels to create raised or stepped decks, too.

In all cases the bearer modules have been built as separate items, connected in situ and then boarded out.

### Connect deck bearer frame modules

Constructing separate modules which link together in a number of ways makes construction on site more manageable, especially if you are working on your own.

**1. Assemble a basic deck** Follow the instructions on page 2 for assembling a basic deck bearer frame to create your desired modules.

**2. Group the modules** Lay each module in place to ensure you have the layout right and make any alterations necessary. See **Fig. 10** (see page 5).

**3. Attach the first modules** Clamp then connect the first two modules together with external grade 150mm (6in) screws through the bearers at no more than 300mm centres. If one or more modules are to be positioned next to a house or outbuilding, it is best to connect these first and check they are lined up correctly, before starting the next.

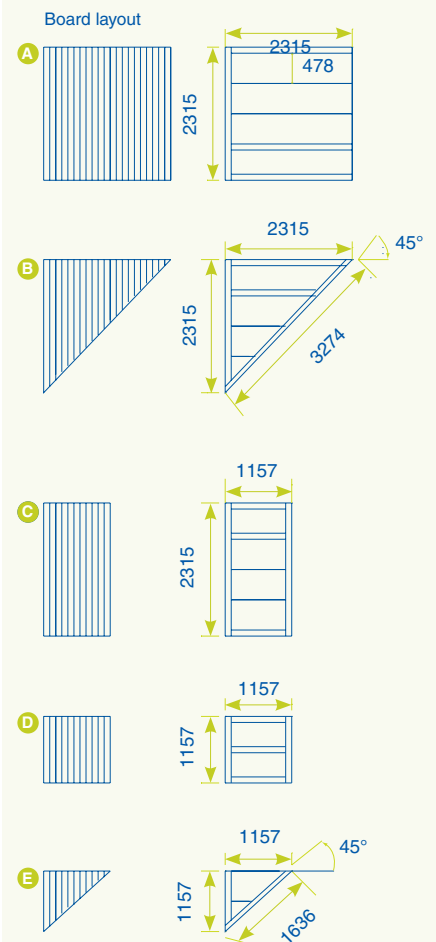
**4. Connect the remaining modules** See **Fig. 11** (see page 5). Continue to clamp and connect your modules together by screwing them into position, checking as you go that each module is correctly positioned and level.

### Attach a deck to the wall of the house

If you have to attach a deck to the wall of a house, establish where the deck frame will meet the wall. Ensure that the frame will not be obstructing an airbrick, and that it is at least 150mm (two brick courses) below the damp proof course.

Fix the beam to the wall with expanding masonry bolts and washers spaced every 400mm. Use 6mm plastic packers between the beam and the wall to leave a clear drainage gap to allow rainwater to run down the wall.

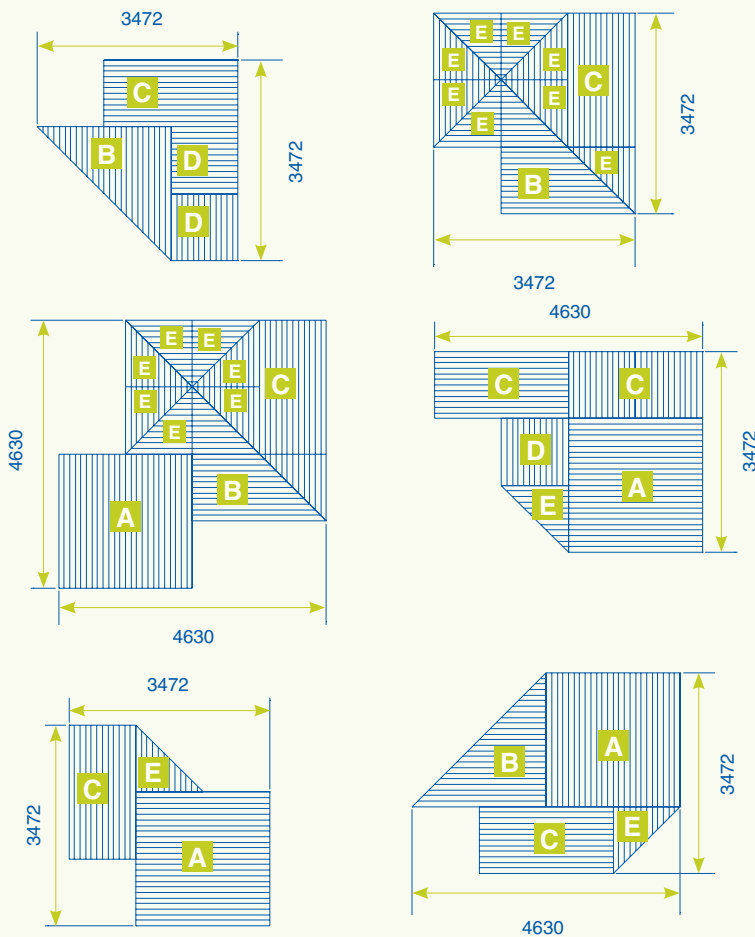
**Fig. 9** Bearer layout modules using 80 x 80mm bearers



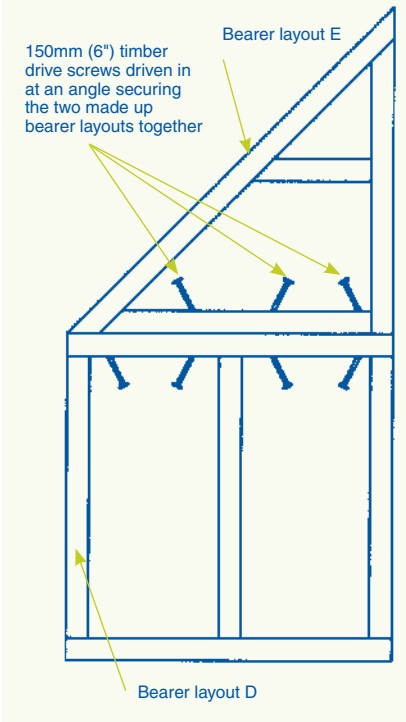
### Materials List

<b>A</b>	7	3m Bearers
	16	2.4m x 140mm Deck boards
	160	65mm (no.8 x 2½") Decking screws
	20	150mm (6") Timber drive screws
<b>B</b>	4	3m Bearers
	8	2.4m x 140mm Deck boards
	106	65mm (no.8 x 2½") Decking screws
	18	150mm (6") Timber drive screws
<b>C</b>	4	3m Bearers
	8	2.4m x 140mm Deck boards
	80	65mm (no.8 x 2½") Decking screws
	20	150mm (6") Timber drive screws
<b>D</b>	2	3m Bearers
	4	2.4m x 140mm Deck boards
	48	65mm (no.8 x 2½") Decking screws
	12	150mm (6") Timber drive screws
<b>E</b>	2	3m Bearers
	2	2.4m x 140mm Deck boards
	20	65mm (no.8 x 2½") Decking screws
	10	150mm (6") Timber drive screws

**Fig. 10** Design layouts using the individual modules shown in diagram E in Fig. 9)



**Fig. 11** Connecting bearer modules with screws



**Trade Tip** As you work, collect timber off-cuts which you can use as deck strengtheners.

# 5 Building a raised deck

## Building a raised deck

If the deck is going over a sloping or uneven site, you may need to build a partly or fully-raised deck.

### Build a frame for a raised deck

Construct the frame or frames using 150mm stress-graded joists and 150mm (6") timber drive screws to join the timbers together.

**1. Construct the frame** It is easiest if you make up the outer deck bearer frame first (see page 2) and then use temporary legs to support it in position.

**2. Check the frame** When the deck bearer frame is in the correct position and you have checked that it is level, dig out the post holes.

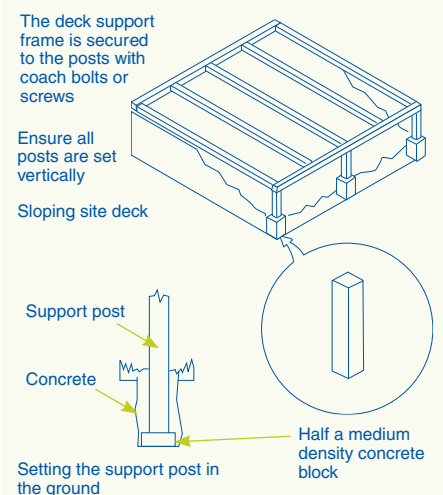
**3. Position post holes** Post holes should be at the corners of the frame and at a maximum of 1200mm centres. Most will need to be 700mm deep although this does depend on your soil type. Use half a

medium density block at the base of the hole and position the post ensuring that it is truly vertical with a spirit level. See **Fig. 12**.

**4. Set the posts in position** Don't cut the posts to the desired length on an uneven site. It is easier to set over-long posts in place first, ready to be trimmed to the right height once the framing joists are attached and double-checked.

**5. Secure the posts to the frame** Use coach bolts or screws to secure the deck bearer frame to the posts, working to a 1:80 fall to encourage rainwater drain off, and pour Postcrete or a concrete mix into the post holes, checking that the posts remain truly vertical. Ensure that the mix sits proud of the soil and that it slopes away from the timber post on all four sides.

**Fig. 12** Positioning posts for a raised deck



This will help with rainwater run-off to prolong the life of the wood. When the mix has cured, remove the temporary legs or you could use Erecta plates.

**6. Position intermediate joists** Set the intermediate joists with maximum centres of 400mm. Depending on the size of the deck, intermediate post supports may also be required on the intermediate joists to reduce any movement on the deck surface. See **Fig. 13** (see page 6).

## Trade Tip

Decking posts set into concrete will inevitably come into contact with moisture over time, which will shorten their life. A good alternative to support posts is to use Erecta Plates, which can be bolted on to a concrete base. You can use these to build a deck over existing concrete or paving, too.

## Install decking steps

Adding a pair of pre-made step risers is the simple way to create steps for your deck. If the steps are wider than 500mm, they will require additional support timbers.

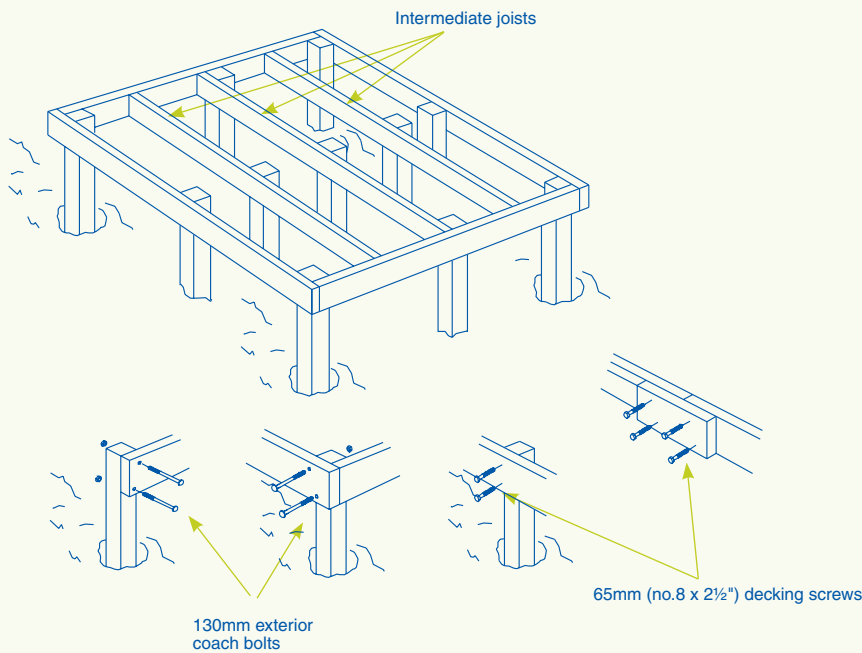
**1. Cut the treads** With the width decided, cut two lengths of deck board to fit between the two risers and secure these with 150mm (6") timber drive screws, making a pilot hole first. See **Fig. 14**.

**2. Fix the steps to the deck** Attach the risers to the deck frame with 65mm (no.8 x 2½") decking screws. Fit deck boards to create steps. If required, you can also fit deck boards at the back of the step – see **Fig. 14**.

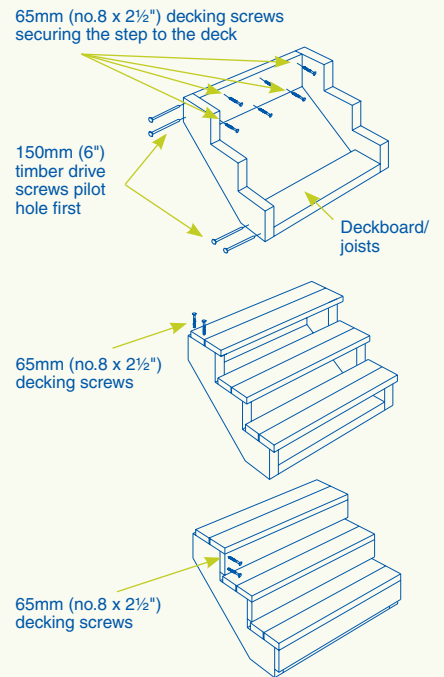
## Trade Tip

For decking posts that will be out of view, trimming the top at an angle will help water to run off and preserve the post.

**Fig. 13** Setting intermediate joists for a raised deck



**Fig. 14** installing steps for a raised deck



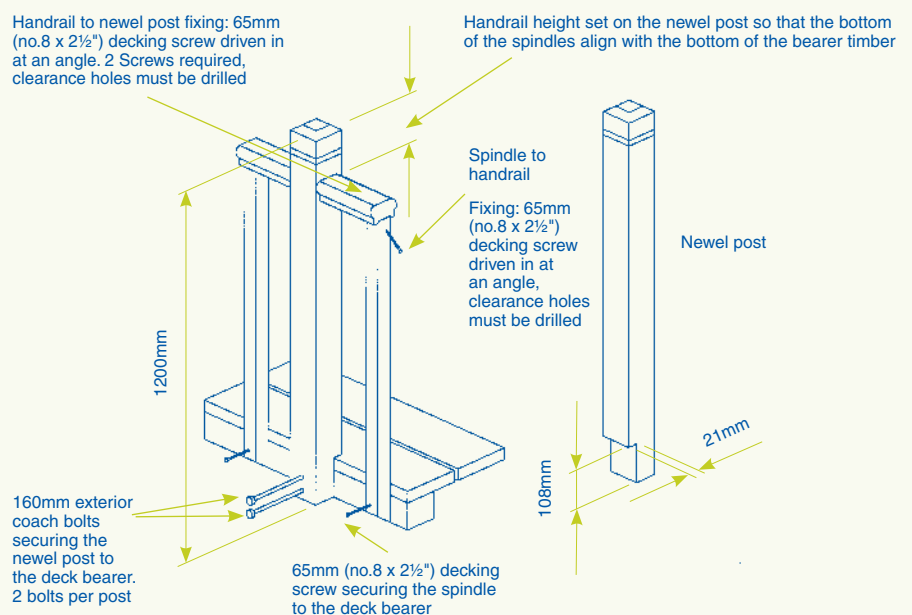
# 6

## Fitting handrails & spindles to the deck

Handrails and spindles should always be fitted to raised decks for safety.

**1. Start with newel posts** Notch out the newel posts as shown in **Fig. 15** and fix to the bearer frame using two 160mm exterior coach bolts per post.

**Fig. 15** Fitting newel posts and handrails to a raised deck



**2. Mark out the handrail** Set the handrail height on the newel post so the bottom of the spindles will align with the bottom of the deck bearer.

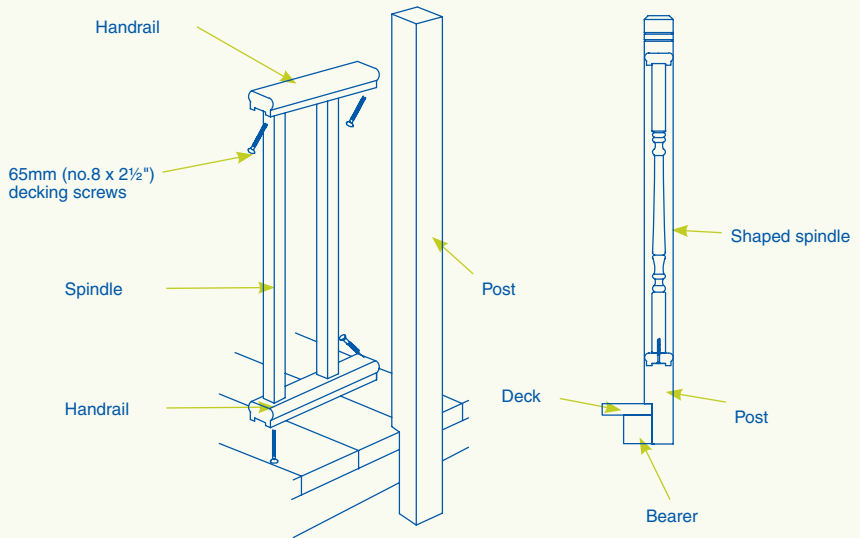
**3. Fix the handrail** Drilling clearance holes first, fix the handrails to the newel posts using two 65mm (no.8 x 2½\") decking screws, driven in at an angle see **Fig. 15** (see page 7).

**4. Fit square spindles** If you are using square spindles, fix them to the bearer and handrail with 65mm (no.8 x 2½") decking screws. The spindles should be spaced so that a 100mm sphere cannot be passed through the gaps see **Fig. 16**.

**5. Fit shaped spindles** For shaped spindles, use a handrail as the base rail and assemble the spindle, base and handrail before positioning them between the newel posts, as shown in **Fig. 16**. Drive 65mm (no.8 x 2½") decking screws through the base rail into the centre of the spindles and, at the top, drive the screws into the handrail at an angle.

**6. Attach to the steps** Fit the newel post, handrail and spindles to the steps as shown in **Fig. 17**.

**Fig. 16** Fitting spindles on a raised deck

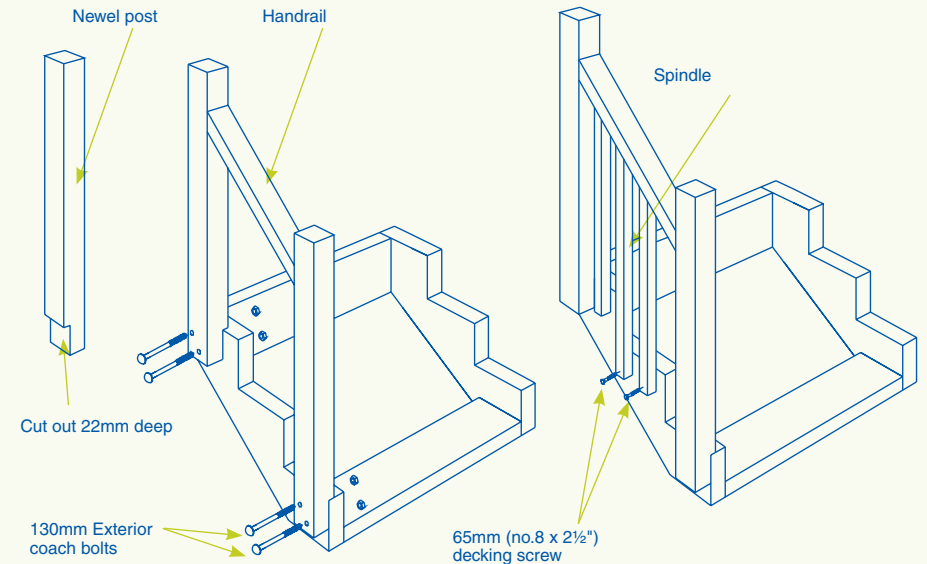


**Trade Tip**

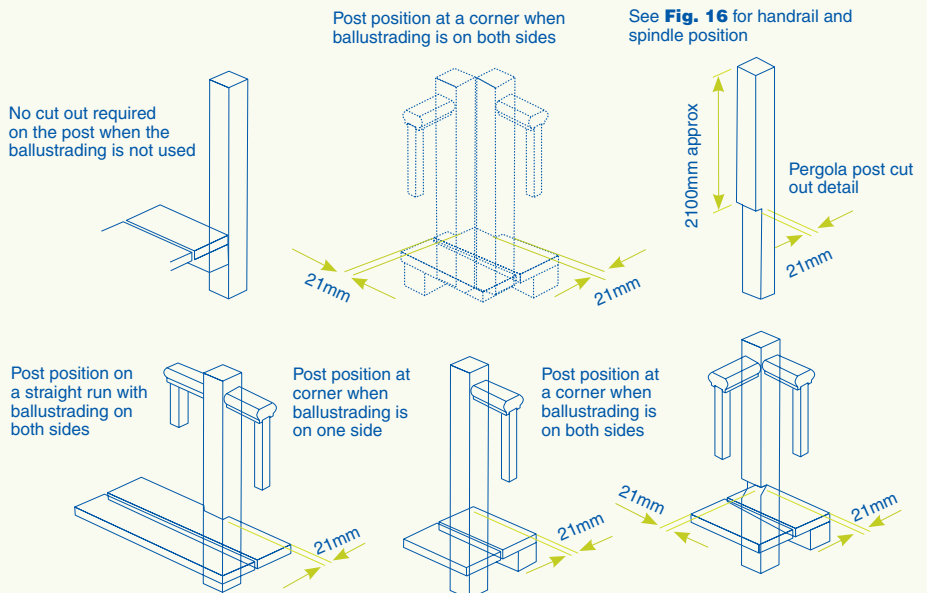
Make spacing the spindles quicker and easier by making a jig from two off cuts of wood or MDF; set the spacing at around 100mm. When attaching spindles, start at the centre and work outwards so that the space at either end is equal.



**Fig. 17** Fitting a handrail to steps on a raised deck



**Fig. 18** Positioning pergola posts on a deck



Where the post butts up to the deck bearer secure using two 160mm exterior coach bolts. All the posts are concreted in the ground

# 7 Building a pergola

Plan your pergola on your deck layout first. The same pergola components can be used to build a freestanding feature or build a canopy off the house wall, too.

**1. Decide on the pergola's position**

Position and connect the pergola posts as shown in **Fig. 18**. Corner posts are located slightly differently to intermediate posts but they all need housing cut out to enable the posts to overlap the deck by 21mm wherever balustrading is to be added.

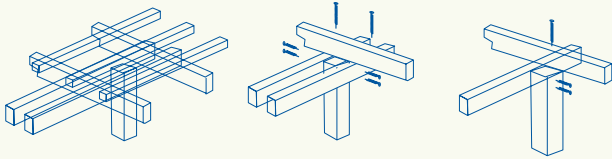
Overlap is essential if you are using balustrading because handrails are connected to the posts in some cases and to newel posts in others, and they need to be aligned. The 21mm cut-out is duplicated on the newel posts, while the square spindles are fitted directly to the outside face of the deck bearers. See **Fig. 16** for newel posts, spindle location and fixings.

**Fig. 19** Constructing the top of the pergola

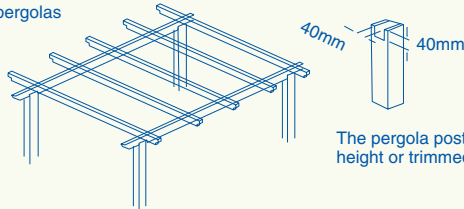
**Option one:** notch the top of the pergola post as shown. Position the pergola cross beam in the post notch, ensuring the beam is level. Secure through the post into the beam using 65mm (no.8 x 2½") decking screws.

Lay the other pergola cross beam on top and secure using 150mm timber drive screws from the top. Clearance and pilot holes should be drilled.

**Option two:** do not notch this post. Secure two pergola cross beams either side of the post, using 65mm (no.8 x 2½") decking screws. Ensure the beams are level. Lay the other cross beam on top and secure using 150mm timber drive screws from the top. Clearance and pilot holes should be drilled.



Deck edge timbers can also be used on top of pergolas



The pergola posts can be set to the same height or trimmed after fitting.

Spindles must be spaced so that a 100mm sphere cannot be passed through the gaps.

**2. Secure the pergola** If your pergola requires a vertical support part of the way across a deck, locate this before any others that have to be in line with it. Remove deck boards to locate a frame bearer. Secure the post to the bearer using two 160mm exterior coach bolts. Ensure it extends into a hole in the ground and is concreted in place, as in step 3 (below). Remove a section from the deck boarding to fit around the post.

**3. Fix the posts** Concrete the posts into the ground adjacent to the deck, or secure them firmly to the deck frame posts. Don't cut them off at deck base level as they won't be stable. For a pergola on a raised deck, ensure that the pergola uprights are firmly attached to the deck frame. Use additional timbers if necessary. All posts must be set vertically.

**4. Complete the pergola** Construct the top of the pergola using one of the options shown in **Fig. 19**.

**Finish and care for the deck**

To keep your deck in the best condition, annually treat all surfaces of the deck with either a Decking Preserver or Stain. Pay particular attention to any end grains, finials and spindles and make sure you coat all sides of the deck. Patio & Decking Cleaner will remove any growth of moss or algae from the boards.

# Product Checklist

Please refer to our catalogue or website for our very latest range and availability.

- Deck Board 25 x 120mm x 2.4m
- Deck Board 28 x 140mm x 2.4m
- Deck Board 28 x 140mm x 3.6m +
- Deck Board 28 x 140mm x 4.8m +
- Deck joist 47 x 150mm x 3m
- Deck Bearer / Pergola Upright 80 x 80mm x 3m
- Pergola Cross Beam 40 x 90mm x 2.4m
- Easy Deck Bearer 70 x 70mm x 2.4m
- Easy Deck Bearer 70 x 70mm x 3.0m
- Modern Deck Post 80 x 80mm x 1.2m
- Modern Deck Post (Notched) 80 x 80mm x 1.37m
- Traditional Deck Post 80 x 80mm x 1.193m
- Deck Post Flat Cap
- Deck Post Square Ball
- Deck Post Ball
- Modern Deck Handrail 2.4m
- Modern Deck Spindle 36 x 36mm x 1.064m
- Traditional Shaped Spindle 36 x 36mm x 812mm

- Decking Stair Stringer (3 Tread) 855 x 525mm (D x H)
- Lattice Privacy Deck Panel 760 x 1130 x 35mm
- Traditional Railing Kit 1816 x 952mm
- Tuscany Railing Kit 1816 x 946mm
- 2.5L Decking Preserver
- Landscape Fabric 20m x 1m
- Landscape Fabric 50m x 1m
- Heavy Duty Landscape Fabric 12m x 1m
- Pea Shingle Major Bag
- Postcrete Concrete 20kg

**Fixings**

- Rail to Post Fitting Kit
- Decking Screws 2½" Pk 200
- Decking Screws 3" Pk 2150
- Exterior Coach Bolts M10 x 160mm Pk 4
- Exterior Coach Bolts M10 x 130mm Pk 4
- Timber Drive Screws 150mm (6")

+ Selected stores only

Our Wickes Project Guides cover a wide range of indoor and outdoor projects, and are regularly updated. Pick them up in store or view them online at [www.wickes.co.uk](http://www.wickes.co.uk).

Whilst every care has been taken to ensure that the product design, descriptions, specifications and techniques of constructing the products are accurate at the date of printing. Wickes products will inevitably change from time to time and the customer is advised to check that the design, descriptions, specifications and techniques of constructing any of the products described in this leaflet are still valid at the time of purchase or placing an order. © Wickes Building Supplies Limited 2014. All rights reserved. No part of this publication may be produced or transmitted in any form or by any means electronic, mechanical, photocopying, recording or otherwise or stored in any retrieval system of any nature without the written permission of the copyright holder and the publisher.