

8. To adjust the full flush volume, raise/lower the full flush adjuster on the flush valve (B), the lower the cap is set the higher the flush volume will be. (see Fig. 7)
Note: the flush valve is preset to flush 6 litres (nominal) when the water level is correctly set to the waterline marked inside the cistern.

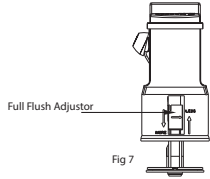

9. To adjust the reduced flush move slide down for more and up for less. (see Fig 8).



10. To fit the flush button, insert button through cistern lid and secure using chrome bezel and locking nut provided, then push flush button locking slide on push button housing and insert flush button (making sure that the flush button is locked in place). Place the cistern lid onto the cistern.

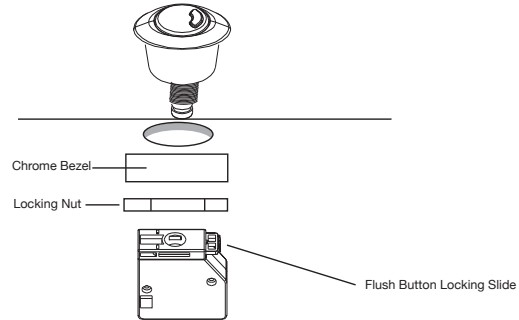

Care & Use

Use warm, soapy water and a soft damp cloth to clean the surface of the product. Wipe dry with a clean cloth. Never use any solvents, scourers, abrasives bleach, acids, strong detergents, aggressive chemical cleaners, or solvent-type cleaning solutions on the product. Do not drop any hard objects on the toilet, seat or cover. Damage may result with cracks or leaks.

Important: retain this information for future reference.

Assembly Instructions

Close-Coupled WC

Parts Supplied

Ref.	Description	Illustration	Qty.
A	Push-Button		1
B	Flush Valve		1
C	Rubber Washer		1
D	Backnut		1
E	Sealing Gasket (Donut washer)		1
F	Inlet Valve		1
G	Inlet Rubber Washer		1
H	Backnut		1

I	Bolt		2
J	Plastic Shroud		2
K	Sealing Washer		2
L	Plastic Washer		4
M	Nut		2
N	Wingnut		2
O	Cistern Lid		1
P	Cistern		1
Q	Pan		1

Tools Required (not supplied)

Slotted screwdriver
Adjustable spanner

Parts Required (not supplied)

Suitable Floor Fixings

Before You Start

- Check the pack and make sure you have all the parts listed above. If not, contact your vendor, who will be able to help you.
- Ensure that you shut off the mains water supply completely before proceeding with the installation
- When you are ready to start, make sure that you have the right tools to hand, plenty of space and a clean, dry area for assembly. Ensure the mounting surface is clean, dry and level before this toilet is installed.
- **Please note:** if you are in any doubt about installing this product, consult a technically competent installer.

Safety

For domestic use only.

Caution: care should always be taken when drilling into walls and floors to avoid any sunken wires or pipes. When drilling through ceramic tiles use a specialist drill bit. Where possible drill between tiles through the grout

When the installation is complete, turn the water supply on and check for leaks around the toilet, cistern inlet and waste connections.

Caution: do not overtighten the fixings otherwise it may damage the product.

Caution: fragile - handle the product with care. This product may cause personal injury, property damage or break if not handled, positioned and installed with care.

Caution: always ensure the product is securely installed before use. Failure to follow these instructions may result in personal injury, damage to the product or property damage.

Assembly

1. Place inlet valve (F) through inlet hole with rubber washer (G) inside the cistern. Secure with backnut (H) but ensure float moves freely up and down flush valve. (see Fig. 1).

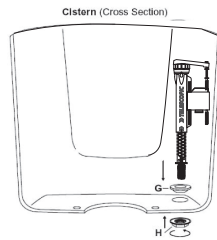
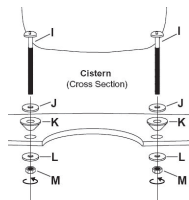

Fig. 1

2. Slide bolt (I) through plastic shroud (J) rubber sealing washer (K) then place through cistern, securing with washer (L) and nut (M) using adjustable spanner (see Fig. 2).



3. Assemble the flush valve (B) through cistern with rubber washer (C) on the inside of the cistern. Secure using fixing nut (D). Take care not to over tighten. (see Fig. 3).

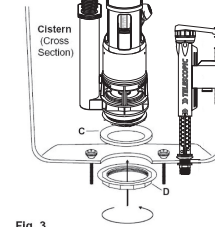

Fig. 3

4. Slide donut washer (E) over fixing nut (D) and slide cistern onto pan backplate by locating screws through the pan.

5. Secure the cistern to the pan using washer (L) and wingnut (N). (see Fig. 4).

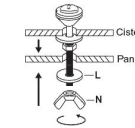

Fig. 4

6. To set the water level, connect the water supply, set the float cup level with the waterline by turning the adjustment rod on the inlet valve (F) so that the float sits level with the float cup, ensure the float (when raised) does not eject from the float cup. (see Fig. 5)

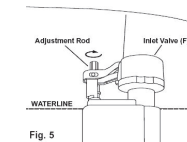

Fig. 5

7. To set internal overflow level, measure from the base of cistern to waterline and add 20 to 50mm, ensure that the top of the overflow is a minimum of 10mm below any aperture in the cistern (e.g. fixing holes). To adjust overflow tube slide the overflow tube clip on the flush valve (B) (see Fig. 6), raise/lower to suit the installation, when height is set slide the overflow tube clip back to secure.

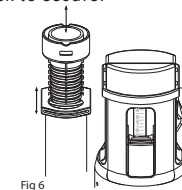

Fig 6