

207013 - Modena Mono mixer

Useful Information	
Minimum operating pressure	0.2 bar
Maximum operating pressure	5 bar
Guarantee length	2 years

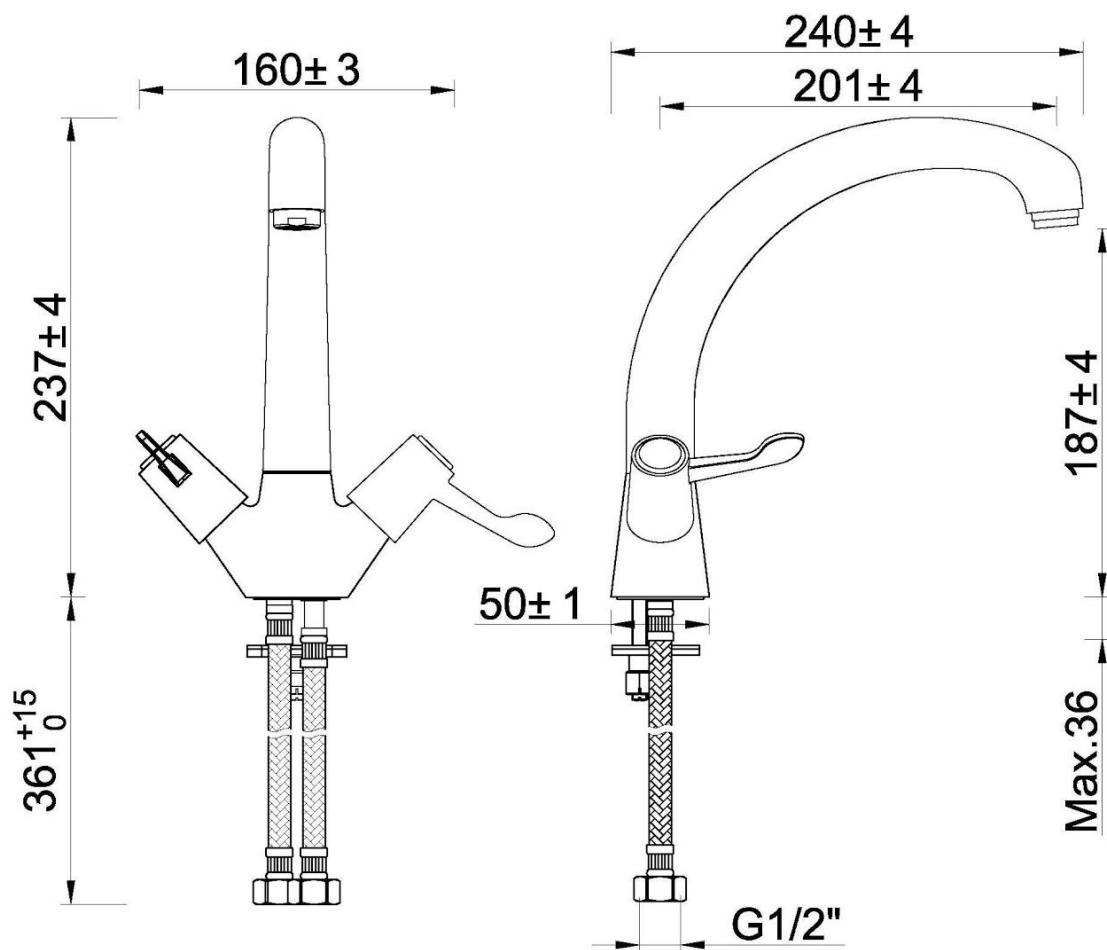

Technical Diagram



Exploded

Diagram

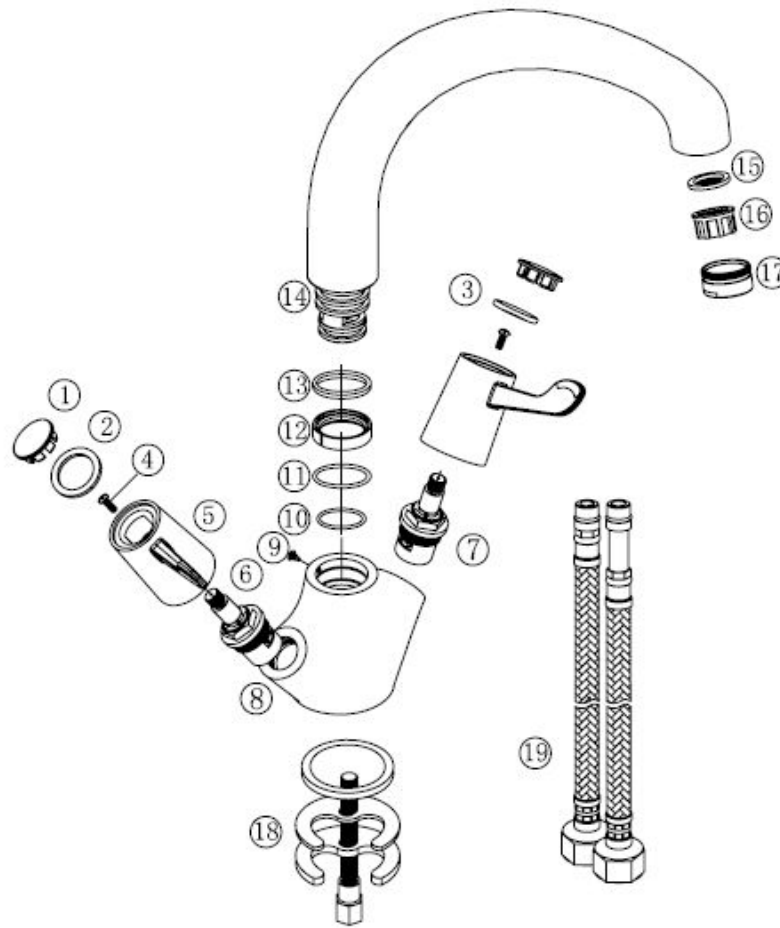

Item Number	Supplier Ref	Item Description	Quantity	Material	Spares Available
1	P51-D	Indice	2	ABS	Yes
2	P51-B H	Indice Seat	1	PE	Yes
3	P51-B C	Indice Seat	1	PE	Yes
4	SC4-12S/L	Screw	2	Stainless Steel	Yes
5	H51-E	Handle	2	ZINC	Yes
6	VS01-C20	1/2" CD Valve	1	BRASS+EPDM+Ceramic Disc	Yes
7	VS01-C20	1/2" CD Valve	1	BRASS+EPDM+Ceramic Disc	Yes
8	M0113Z-01	Tap Body	1	BRASS	No
9	SC4-7.5S	Screw	1	Stainless Steel	Yes
10	OR014	O ring	1	EPDM	Yes
11	OR015	O Ring	1	EPDM	Yes
12	M33247-N1	Block Ring	1	POM	Yes
13	M0112-02-01	Washer	1	POM	Yes
14	167020-02	Spout	1	BRASS	No
15	A13-04X	Washer	1	EPDM+Stainless Steel	Yes
16	A13-02	Flow straightener	1	POM	Yes
17	A14-04	Flow straightener Shell	1	ABS	Yes
18	N24-F	Fixing kit	1	Steel+NBR+Brass	Yes
19	BZG12-1/2"-370	Braided Connectors	1	Stainless Steel+BRASS+ EPDM	Yes

Flow Rates

FAQ

What should I do if my tap is dripping/leaking?

Cleaning the valve (if water dripping from tap)

Before carrying out any maintenance, turn off the mains water supply. If unsure contact a qualified tradesman.

1. Remove the cap (e), grub screw (a), handles (b).
2. Remove the valve (d) using a suitable spanner, clean thoroughly under cold water
3. to remove any build up of limescale or debris.
4. If necessary replace the valve.
5. Replace the valve (d) into the body, tighten the valve using a suitable spanner.
6. Replace the handles (b) and indice (f), tighten the grub screw (a).
7. Re-fit the cap (e) to handle.

What does the Guarantee Cover?

The Guarantee Covers leakage, manufacturing defects and Chrome Plating.

The guarantee does not cover:

- Damage or defects caused by:
 - general wear and tear (including special non-chrome finishes; components such as filters, seals, 'O'rings and washers)
 - incorrect installation
 - repair using non- PPI parts
 - accidental or wilful misuse
 - corrosion and the use of inappropriate cleaning products.
 - system debris including the build up of limescale (which can be controlled through regular servicing and maintenance).
- Compensation for loss of use of the product or consequential loss of any kind.