

410150- Trade Pillar taps

Useful Information	
Minimum operating pressure	0.1 bar
Maximum operating pressure	5 bar
Guarantee length	2 years

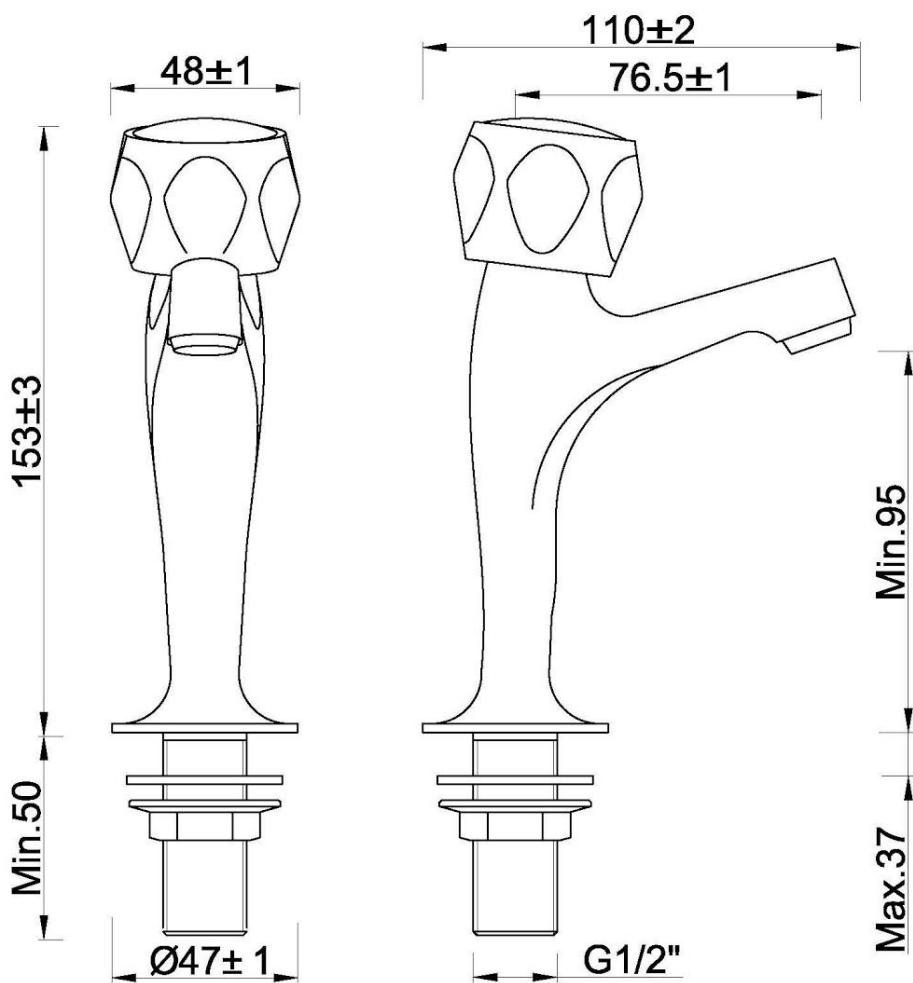

Technical Diagram



Exploded Diagram

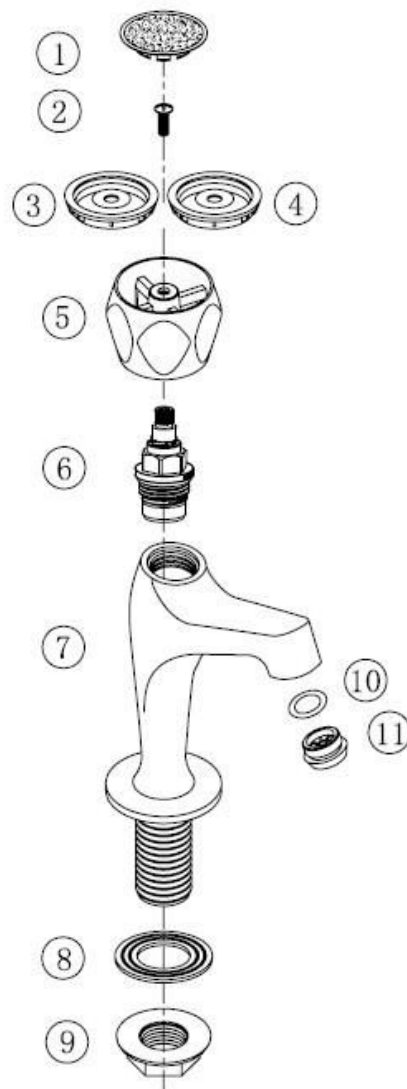

Item Number	Supplier Ref	Description	Quantity	Material	Spares Available
1	P01-A	Indice	2	ABS	Yes
2	SC4-10S	Screw	2	Stainless Steel	Yes
3	P01-C H	Indice Seat	1	ABS	Yes
4	P01-C C	Indice Seat	1	ABS	Yes
5	H01-C	Handle	2	ZINC	Yes
6	VS5412-BZ20	Valve	2	BRASS+EPDM	Yes
7	M33143-01	Tap Body	2	BRASS	
8	N08	Washer	2	NBR	Yes
9	N01-C	1/2" Back Nut	2	ZINC	Yes
10	OR003	O Ring	2	EPDM	Yes
11	A01-A	Flow straightener	2	POM	Yes

Flow Rates

FAQ

What should I do if my tap is dripping/leaking?

Cleaning the valve (if water dripping from tap)

Before carrying out any maintenance, turn off the mains water supply. If unsure contact a qualified tradesman.

1. Remove the cap, grub screw and handles.
2. Remove the valve using a suitable spanner, clean thoroughly under cold water to remove any build up of limescale or debris.
3. If necessary replace the valve.
4. Replace the valve into the body, tighten the valve using a suitable spanner.
5. Replace the handles and indices, tighten the grub screw and re-fit cap to handles.

What does the Guarantee Cover?

The Guarantee Covering leakage, manufacturing defects and Chrome plating

The guarantee does not cover:

- Damage or defects caused by:
 - general wear and tear (including special non-chrome finishes; components such as filters, seals, 'O'rings and washers)
 - incorrect installation
 - repair using non- PPI parts
 - accidental or wilful misuse
 - corrosion and the use of inappropriate cleaning products.
 - system debris including the build up of limescale (which can be controlled through regular servicing and maintenance).
- Compensation for loss of use of the product or consequential loss of any kind.