

410710 - Angara Mono mixer

Useful Information	
Minimum operating pressure	0.2 bar
Maximum operating pressure	5 bar
Guarantee length	5 years

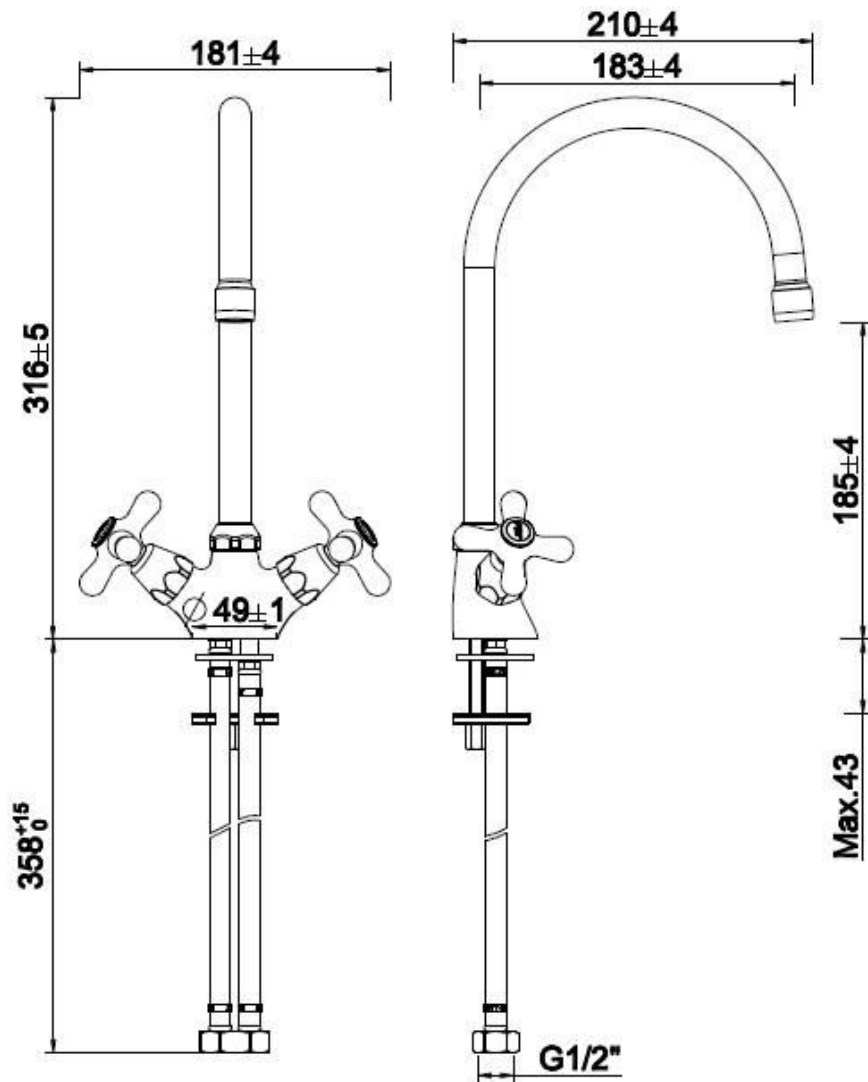

Technical Diagram



Exploded Diagram

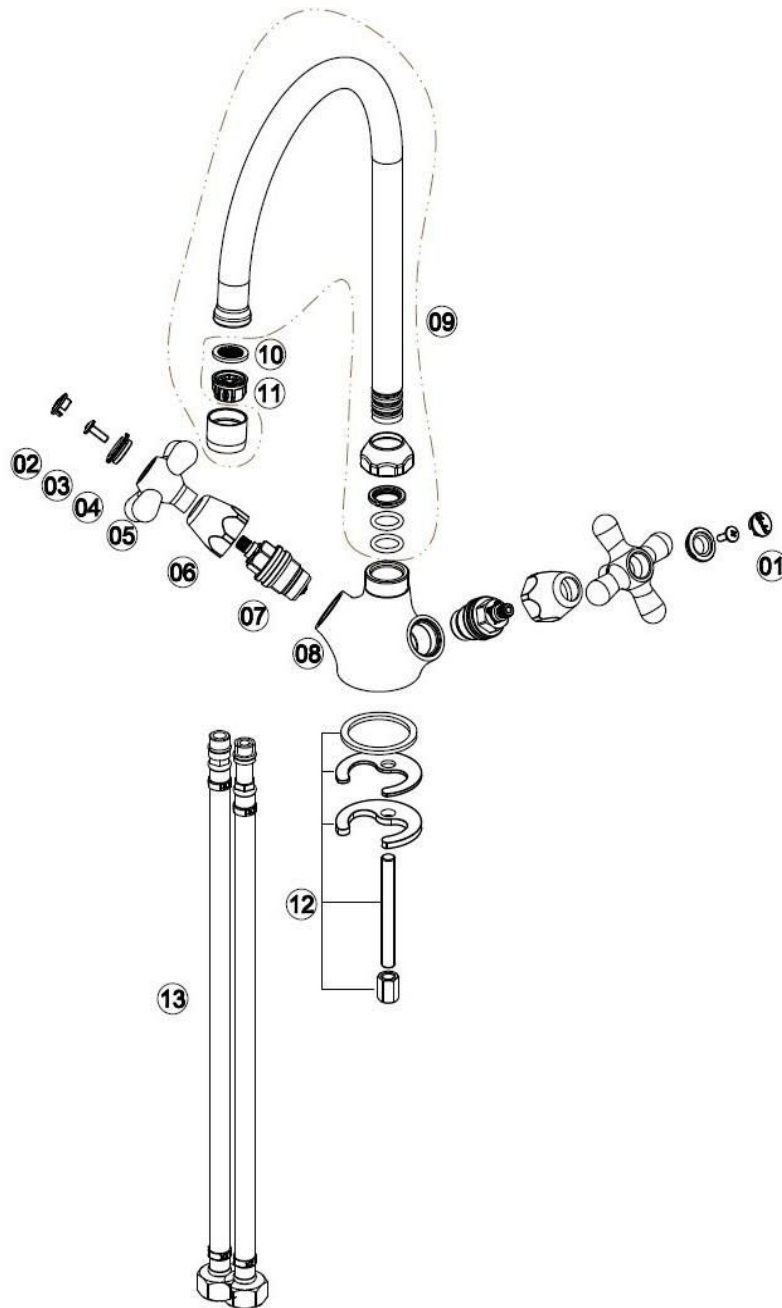

Item Number	Supplier Ref	Description	Quantity	Spares Available
1	P08-C	Indice(Cold)	1	Yes
2	P08-H	Indice(Hot)	1	Yes
3	SC4-12S/L	Screw	2	Yes
4	H64-S	Indice Seat	2	Yes
5	147013-H-Z	Handle Seat	2	Yes
6	147013-S	Valve Cover	2	Yes
7	VS5412-BZ20	Valve	2	Yes
8	147013-01	Tap Body	1	No
9	147013-02	Spout	1	No

10	A14-01	Washer	1	Yes
11	A13-02	Flow straightener	1	Yes
12	147013-N	Fixing kit	1	Yes
13	BZG12-1/2"-370	Braided Connectors	1	Yes

Flow Rates

FAQ

What should I do if my tap is dripping/leaking?

Cleaning the valve (if water dripping from tap)

Before carrying out any maintenance, turn off the mains water supply. If unsure contact a qualified tradesman.

1. Remove the cap (e), grub screw (a), handles (b).
2. Remove the valve (d) using a suitable spanner, clean thoroughly under cold water
3. to remove any build up of limescale or debris.
4. If necessary replace the valve.
5. Replace the valve (d) into the body, tighten the valve using a suitable spanner.
6. Replace the handles (b) and indice (f), tighten the grub screw (a).
7. Re-fit the cap (e) to handle.

What does the Guarantee Cover?

The Guarantee Covering leakage, manufacturing defects and Chrome plating

The guarantee does not cover:

- Damage or defects caused by:
 - general wear and tear (including special non-chrome finishes; components such as filters, seals, 'O'rings and washers)
 - incorrect installation
 - repair using non- PPI parts
 - accidental or wilful misuse
 - corrosion and the use of inappropriate cleaning products.
 - system debris including the build up of limescale (which can be controlled through regular servicing and maintenance).
- Compensation for loss of use of the product or consequential loss of any kind.